

**1216 RESISTANCE OF ABRASION OF COARSE AGGREGATE TO
DEGRADATION BY ABRASION IN THE
MICRO-DEVAL APPARATUS**

Ontario Standard Test Method LS-618 (MN/DOT Modified)

1216.1 SCOPE

This test method is intended for use in determining the toughness/abrasion resistance and durability/soundness of coarse aggregate subject to abrasion and weathering action. The test consists of subjecting specifically graded samples of coarse aggregate to soaking in water and then to abrasion in a jar mill with water and a specific charge of stainless steel balls. The jar with water, stainless steel balls and the sample is then revolved in the micro-Deval apparatus at 100 rpm for two hours. The sample is then re-graded and the loss determined.

1216.2 APPARATUS

- A. Balance - Shall conform to AASHTO M 231 (Class G2). Readability & sensitivity 0.1 grams, accuracy 0.1 grams or 0.1%.
- B. Container - A stainless steel micro-Deval abrasion jar having a 5-litre capacity with a rubber ring in the rotary locking cover. The internal diameter shall be 194 ± 2.0 mm and the internal height shall be 170 ± 2.0 mm. The inside and outside surface of the jars shall be smooth and have no observable ridges or indentations.
- C. Micro-Deval Abrasion Machine - A jar rolling mill capable of running at 100 ± 5 rpm. (See Section 1216.8)
- D. Abrasion Charge - Consisting of 5000 ± 5 g of stainless steel balls having a diameter of 9.5 mm ($3/8$ ") ± 0.5 mm.
- E. Sieves - Sieves with square openings and of the following sizes conforming to AASHTO M 92 specifications: 19.0mm ($3/4$ "), 16.0mm ($5/8$ "), 12.5mm ($1/2$ "), 9.5mm ($3/8$ "), 6.7mm (0.265"), 4.75mm (#4) and 1.18mm (#16).
- E. Oven - Capable of maintaining a temperature of 110 ± 5 °C (230 ± 9 °F).
- F. Laboratory Control Aggregate - A supply of standard "Brechin Quarry" coarse aggregate.

NOTE 1: The above aggregate is available from: Soils and Aggregates Section, Engineering Materials Office, Ministry of Transportation, 1201 Wilson Avenue, Downsview, Ontario, Canada M3M 1J8

1216.3 TEST SAMPLES

A. The test sample shall be washed and oven-dried to a constant mass at 110 ± 5 °C. (230 ± 9 °F.), separated into individual size fractions according to AASHTO T 27 and recombined to meet the appropriate grading below.

1. For aggregates normally consisting of material passing the 19.0mm (3/4") sieve and retained on the 9.5mm (3/8") sieve a 1500 ± 5 g sample shall be prepared as follows:

PASSING	RETAINED	MASS (g)
19.0mm (3/4")	16.0mm (5/8")	375
16.0mm (5/8")	12.5mm (1/2")	375
12.5mm (1/2")	9.5mm (3/8")	750

2. For aggregates where the nominal maximum size of the coarse aggregate is less than 16.0mm (5/8") a 1500 ± 5 g sample shall be prepared as follows:

PASSING	RETAINED	MASS (g)
12.5mm (1/2")	9.5mm (3/8")	750
9.5mm (3/8")	6.7mm (0.265")	375
6.7mm (0.265")	4.75mm (#4")	375

3. For aggregates where the nominal maximum size of the coarse aggregate is less than 12.5mm (1/2") a 1500 ± 5 g sample shall be prepared as follows:

PASSING	RETAINED	MASS (g)
9.5mm (3/8")	6.7mm (0.265")	750
6.7mm (0.265")	4.75mm (#4")	750

1216.4 TEST PROCEDURE

- A. Prepare the correct $1500 \pm 5\text{g}$, oven-dried sample and record the mass to the nearest 0.1g. ("A" in CALCULATIONS)
- B. Saturate the sample in 2.0 ± 0.5 liters of water at a temperature of 20 ± 5 °C. (68 ± 9 °F.) for a minimum of one hour either in the micro-Deval container or some other suitable container.
- C. Place the sample and water in the micro-Deval abrasion container with $5000 \pm 5\text{g}$ of the stainless steel balls and place the container on the machine.
- D. For the grading shown in Section 1216.3A1 run the machine at 100 ± 5 rpm for 2 hours ± 1 minute.

For the grading shown in Section 1216.3A2 run the machine at 100 ± 5 rpm for 105 ± 1 minutes.

For the grading shown in Section 1216.3A3 run the machine at 100 ± 5 rpm for 95 ± 1 minutes.
- E. Carefully pour the sample from the container over two superimposed sieves, the 4.75mm (#4) and 1.18mm (#16) sieves.
- F. Using a hand-held water hose (A hand-held sprayer will be found useful) wash and manipulate the retained material until the wash water is clear and all the material smaller than 1.18mm (#16) passes that sieve.
- G. Remove the stainless steel balls using a magnet or other suitable means.
- H. Discard the material smaller than 1.18mm (0.46").
- I. Combine the material retained on the 4.75mm (#4) and 1.18mm (#16) sieves being careful not to lose any material.
- J. Oven-dry the sample to a constant mass at 110 ± 5 °C. (230 ± 9 °F.)
- K. Weigh the sample to the nearest 0.1g and record the mass. ("B" in CALCULATIONS)

1216.5 CALCULATIONS

Where:

A = Initial weight of the sample (From Section 1216.4A)

B = Weight of material retained on the 4.74mm (#4) and 1.18mm (#16) sieves after abrading. (From Section 1216.4K)

NOTE 2: The letter designations above are not the same as on the worksheet (Section 1216.9) as the worksheet includes the pan weight in the calculations.

$$\frac{A - B}{A} \times 100 = \% \text{ Loss}$$

1216.6 REPORT

The maximum size of the aggregate tested and the grading used.

The percent loss of the test sample to the nearest 0.1%.

1216.7 USE OF THE LABORATORY CONTROL AGGREGATE

- A. Every 10 samples a sample of the standard reference aggregate (See Section 1216.2F) shall also be tested. This material shall be taken from a stock supply and prepared according to Section 1216.3.
- B. The percent loss of the last twenty samples of control material shall be plotted on a control chart in order to monitor the variation in results.

NOTE 3: The mean loss of the Brechin control aggregate in a multi-laboratory study of the micro-Deval test is 16.9%. Individual test data of this material should fall within the range of 15.6% to 18.3% loss nineteen times out of twenty.

1216.8 MICRO-DEVAL ABRASION MACHINE AND CONTAINER

Dimensions in millimeters

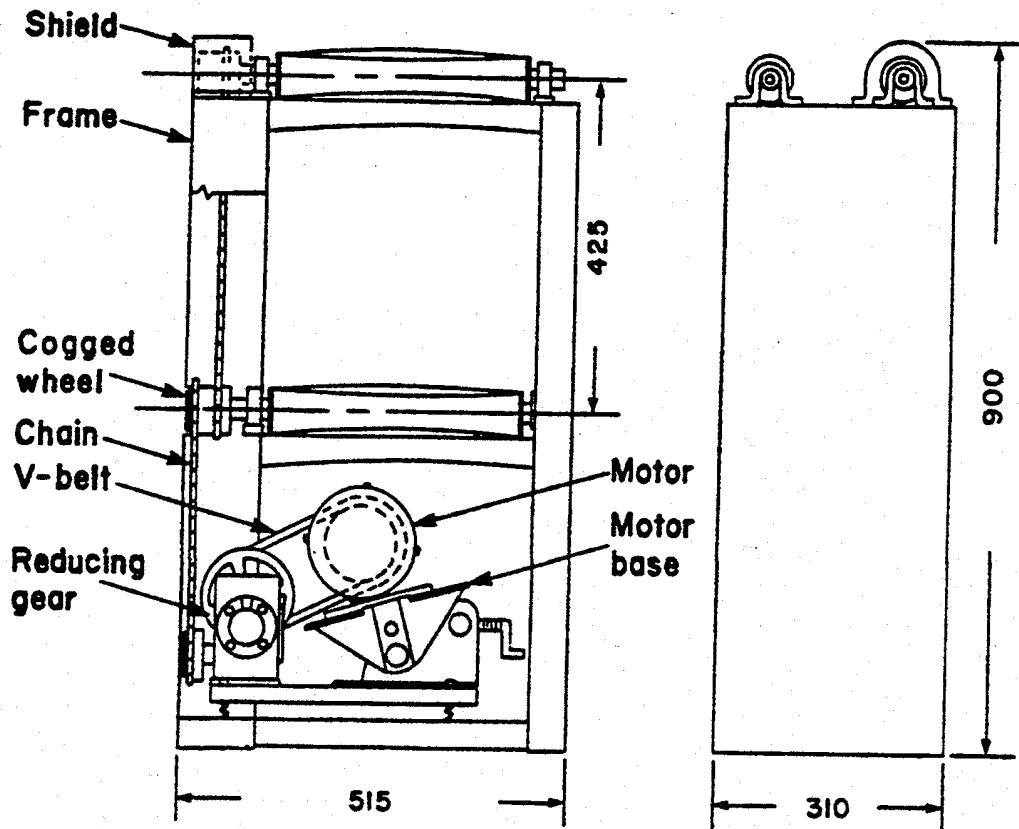
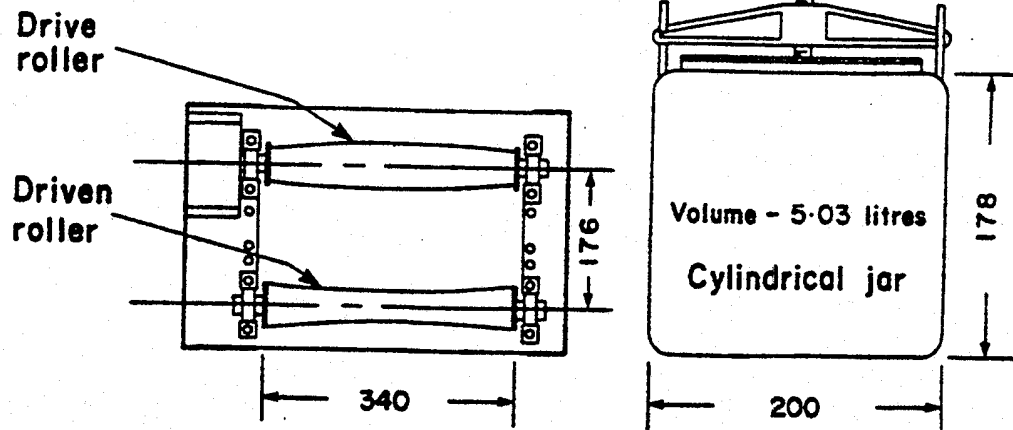

1216.9 SAMPLE WORK SHEET

MICRO-DEVAL SAMPLE DATA SHEET

Sample No. _____ Jar No. _____

Date: _____

SAMPLE INFORMATION

Passing this Sieve		Retained on this Sieve		"A" Grading (3/4"-)		"B" Grading (1/2"-)		"C" Grading (3/8"-)	
mm	Inches	mm	Inches	Required	Actual	Required	Actual	Required	Actual
19.0	3/4	16.0	5/8	375					
16.0	5/8	12.5	1/2	375					
12.5	1/2	9.5	3/8	750		750			
9.5	3/8	6.7	0.265			375		750	
6.7	0.265	4.75	#4			375		750	
TOTAL				1500 ± 5		1500 ± 5		1500 ± 5	

TEST DATA and COMPUTATIONS

Maximum Size of Aggregate Used _____ Grading Used _____

Initial Sample Weight (A) _____ g Weight of Pan (B) _____ g

Final Sample Weight (C) _____ g

$$\text{Percent Loss} = \frac{(A - B) - (C - B)}{(A - B)} \times 100 = \frac{\quad}{\quad}$$