

ALLIANT ENGINEERING, INC.

733 S Marquette Ave #700, Minneapolis, MN 55402

Intersection: TH 65 & Bunker Lake Boulevard
 Date: 12/17/2024
 Duration: 0600-1900

Site Code: 111
 Ref Pt: N/A
 Page No: 1 of 4

All Vehicles (Cars & Trucks) Printed

Start Time	TH 65 Southbound						Bunker Lake Boulevard Westbound						TH 65 Northbound						Bunker Lake Boulevard Eastbound						Int. Veh. Total	Int. Ped/ Bike Total
	U-Turn	Left	Thru	Right	App. Total	Peds/ Bikes	U-Turn	Left	Thru	Right	App. Total	Peds/ Bikes	U-Turn	Left	Thru	Right	App. Total	Peds/ Bikes	U-Turn	Left	Thru	Right	App. Total	Peds/ Bikes		
6:00	--	3	384	11	398	--	--	22	18	2	42	--	3	9	66	5	83	--	--	5	13	25	43	--	566	--
6:15	--	8	431	22	461	--	--	26	15	1	42	--	1	14	94	6	115	--	--	10	24	27	61	--	679	--
6:30	--	8	407	27	442	--	--	33	21	4	58	--	2	22	122	10	156	--	--	5	24	43	72	--	728	--
6:45	--	8	428	32	468	--	--	24	34	9	67	--	2	33	137	5	177	--	1	15	31	58	105	--	817	--
Hour Total	--	27	1650	92	1769	--	--	105	88	16	209	--	8	78	419	26	531	--	1	35	92	153	281	--	2790	--
7:00	--	11	385	41	437	--	--	37	87	7	131	--	1	33	138	6	178	--	--	14	33	69	116	--	862	--
7:15	--	6	436	67	509	--	--	28	90	3	121	--	--	51	161	11	223	--	--	17	32	55	104	--	957	--
7:30	--	9	418	46	473	--	--	22	65	5	92	--	5	49	184	10	248	--	--	22	49	73	144	--	957	--
7:45	--	8	333	36	377	--	--	37	65	8	110	--	4	51	155	12	222	--	1	39	42	74	156	--	865	--
Hour Total	--	34	1572	190	1796	--	--	124	307	23	454	--	10	184	638	39	871	--	1	92	156	271	520	--	3641	--
8:00	--	9	318	28	355	--	--	33	48	5	86	--	1	19	153	12	185	--	--	19	39	56	114	--	740	--
8:15	2	7	314	22	345	--	--	28	26	6	60	--	1	32	165	18	216	--	--	17	39	58	114	--	735	--
8:30	--	8	294	15	317	--	--	34	34	10	78	--	--	18	149	19	186	--	--	21	22	49	92	--	673	--
8:45	--	14	292	17	323	--	--	24	27	6	57	--	2	31	150	19	202	--	--	13	38	58	109	--	691	--
Hour Total	2	38	1218	82	1340	--	--	119	135	27	281	--	4	100	617	68	789	--	--	70	138	221	429	--	2839	--
9:00	--	9	280	11	300	--	--	24	28	7	59	--	2	23	165	18	208	--	--	14	20	60	94	--	661	--
9:15	--	6	305	27	338	--	--	35	29	7	71	--	2	33	184	16	235	--	--	16	22	48	86	--	730	--
9:30	--	13	280	30	323	--	--	32	27	8	67	--	--	31	157	30	218	--	1	20	29	42	92	--	700	--
9:45	--	19	244	20	283	--	--	29	26	8	63	--	2	42	155	18	217	--	--	16	32	42	90	--	653	--
Hour Total	--	47	1109	88	1244	--	--	120	110	30	260	--	6	129	661	82	878	--	1	66	103	192	362	--	2744	--
10:00	--	18	238	14	270	--	--	20	21	9	50	--	--	39	213	28	280	--	--	15	24	40	79	--	679	--
10:15	--	12	245	14	271	--	--	19	33	8	60	--	2	31	179	18	230	--	--	14	28	31	73	--	634	--
10:30	1	21	261	20	303	--	--	25	31	10	66	--	--	24	185	24	233	--	--	18	21	49	88	--	690	--
10:45	--	9	225	20	254	--	--	18	31	8	57	--	5	43	201	19	268	--	1	13	29	61	104	--	683	--
Hour Total	1	60	969	68	1098	--	--	82	116	35	233	--	7	137	778	89	1011	--	1	60	102	181	344	--	2686	--
11:00	1	9	220	23	253	--	--	23	32	4	59	--	3	33	206	20	262	--	--	20	24	45	89	--	663	--
11:15	--	2	236	21	259	--	--	25	33	6	64	--	2	33	212	21	268	--	--	19	33	58	110	--	701	--
11:30	--	10	258	17	285	--	--	30	33	9	72	--	3	41	213	22	279	--	--	25	35	41	101	--	737	--
11:45	--	7	252	27	286	--	--	26	38	8	72	--	1	40	221	27	289	--	1	21	26	48	96	--	743	--
Hour Total	1	28	966	88	1083	--	--	104	136	27	267	--	9	147	852	90	1098	--	1	85	118	192	396	--	2844	--
12:00	--	5	211	24	240	--	--	26	25	5	56	--	2	57	211	26	296	--	--	32	25	48	105	--	697	--
12:15	--	11	233	19	263	--	--	44	25	11	80	--	--	54	208	19	281	--	--	25	23	51	99	--	723	--
12:30	--	9	248	20	277	--	--	33	37	11	81	--	--	34	257	24	315	--	--	26	31	39	96	--	769	--
12:45	--	11	247	26	284	--	--	39	31	11	81	--	1	56	257	25	339	--	--	27	28	40	95	--	799	--
Hour Total	--	36	939	89	1064	--	--	142	118	38	298	--	3	201	933	94	1231	--	--	110	107	178	395	--	2988	--
13:00	--	--	222	15	237	--	--	27	29	11	67	--	4	41	279	28	352	--	--	20	25	44	89	--	745	--
13:15	--	6	245	19	270	--	--	20	30	8	58	--	3	53	261	18	335	--	--	14	30	53	97	--	760	--
13:30	--	7	223	16	246	--	--	31	29	9	69	--	2	50	282	23	357	--	--	22	18	47	87	--	759	--
13:45	--	3	210	24	237	--	--	15	26	5	46	--	2	53	345	19	419	--	--	23	33	51	107	--	809	--
Hour Total	--	16	900	74	990	--	--	93	114	33	240	--	11	197	1167	88	1463	--	--	79	106	195	380	--	3073	--
14:00	--	11	211	22	244	--	--	35	41	14	90	--	3	50	266	22	341	--	--	20	34	42	96	--	771	--
14:15	--	8	275	24	307	--	--	25	36	9	70	--	6	56	291	28	381	--	--	35	58	60	153	--	911	--
14:30	1	7	222	21	251	--	--	24	35	15	74	--	3	69	368	40	480	--	--	34	64	58	156	--	961	--
14:45	--	11	220	34	265	--	--	17	39	21	77	--	9	52	336	38	435	--	--	33	59	55	147	--	924	--
Hour Total	1	37	928	101	1067	--	--	101	151	59	311	--	21	227	1261	128	1637	--	--	122	215	215	552	--	3567	--
15:00	--	7	204	23	234	--	--	33	48	12	93	--	3	60	414	37	514	--	--	37	39	53	129	--	970	--
15:15	--	7	258	22	287	--	--	20	42	12	74	--	--	47	428	36	511	--	--	45	69	66	180	--	1052	--
15:30	--	12	220	22	254	--	--	29	48	21	98	--	3	37	413	32	485	--	1	40	40	70	151	--	988	--
15:45	--	17	217	26	260	--	--	1	24	42	66	--	3	66	384	32	485	--	--	49	49	52	150	--	988	--
Hour Total	--	43	899	93	1035	--	--	1	106	180	358	--	9	210	1639	137	1995	--	1	171	197	241	610	--	3998	--
16:00	1	9	275	19	304	--	--	20	54	22	96	--	4	44	447	19	514	--	--	47	39	50	136	--	1050	--
16:15	--	9	214	32	255	--	--	31	69	32	132	--	5	81	398	52	536	--	--	41	69	64	174	--	1097	--
16:30	2	13	309	27	351	--	--	30	57	23	110	--	1	43	415	36	495	--	--	55	59	90	204	--	1160	--
16:45	--	11	247	23	281	--	--	28	68	20	116	--	2	74	400	36	512	--	--	41	58	49	148	--	1057	--
Hour Total	3	42	1045	101	1191	--	--	109	248	97	454	--	12	2												

ALLIANT ENGINEERING, INC.

733 S Marquette Ave #700, Minneapolis, MN 55402

Intersection: TH 65 & Bunker Lake Boulevard
 Date: 12/17/2024
 Duration: 0600-1900

Site Code: 111
 Ref Pt: N/A
 Page No: 2 of 4

All Vehicles (Cars & Trucks) Printed

Start Time	TH 65 Southbound						Bunker Lake Boulevard Westbound						TH 65 Northbound						Bunker Lake Boulevard Eastbound						Int. Veh. Total	Int. Ped/Bike Total
	U-Turn	Left	Thru	Right	App. Total	Peds/Bikes	U-Turn	Left	Thru	Right	App. Total	Peds/Bikes	U-Turn	Left	Thru	Right	App. Total	Peds/Bikes	U-Turn	Left	Thru	Right	App. Total	Peds/Bikes		
7:00	--	11	385	41	437	--	--	37	87	7	131	--	1	33	138	6	178	--	--	14	33	69	116	--	862	--
7:15	--	6	436	67	509	--	--	28	90	3	121	--	--	51	161	11	223	--	--	17	32	55	104	--	957	--
7:30	--	9	418	46	473	--	--	22	65	5	92	--	5	49	184	10	248	--	--	22	49	73	144	--	957	--
7:45	--	8	333	36	377	--	--	37	65	8	110	--	4	51	155	12	222	--	1	39	42	74	156	--	865	--
Hour Total	--	34	1572	190	1796	--	--	124	307	23	454	--	10	184	638	39	871	--	1	92	156	271	520	--	3641	--
% of App.	0.0%	1.9%	87.5%	10.6%			0.0%	27.3%	67.6%	5.1%			1.1%	21.1%	73.2%	4.5%			0.2%	17.7%	30.0%	52.1%				
% of Total	0.0%	0.9%	43.2%	5.2%	49.3%	--	0.0%	3.4%	8.4%	0.6%	12.5%	--	0.3%	5.1%	17.5%	1.1%	23.9%	--	0.0%	2.5%	4.3%	7.4%	14.3%	--		
Cars Total	--	33	1485	180	1698	--	--	121	299	23	443	--	9	176	565	36	786	--	1	85	150	265	501	--	3428	--
Cars % of Movement	0.0%	97.1%	94.5%	94.7%	94.5%	--	0.0%	97.6%	97.4%	100%	97.6%	--	90.0%	95.7%	88.6%	92.3%	90.2%	--	100%	92.4%	96.2%	97.8%	96.3%	--	94.1%	--
Trucks Total	--	1	87	10	98	--	--	3	8	--	11	--	1	8	73	3	85	--	--	7	6	6	19	--	213	--
Trucks % of Movement	0.0%	2.9%	5.5%	5.3%	5.5%	--	0.0%	2.4%	2.6%	0.0%	2.4%	--	10.0%	4.3%	11.4%	7.7%	9.8%	--	0.0%	7.6%	3.8%	2.2%	3.7%	--	5.9%	--

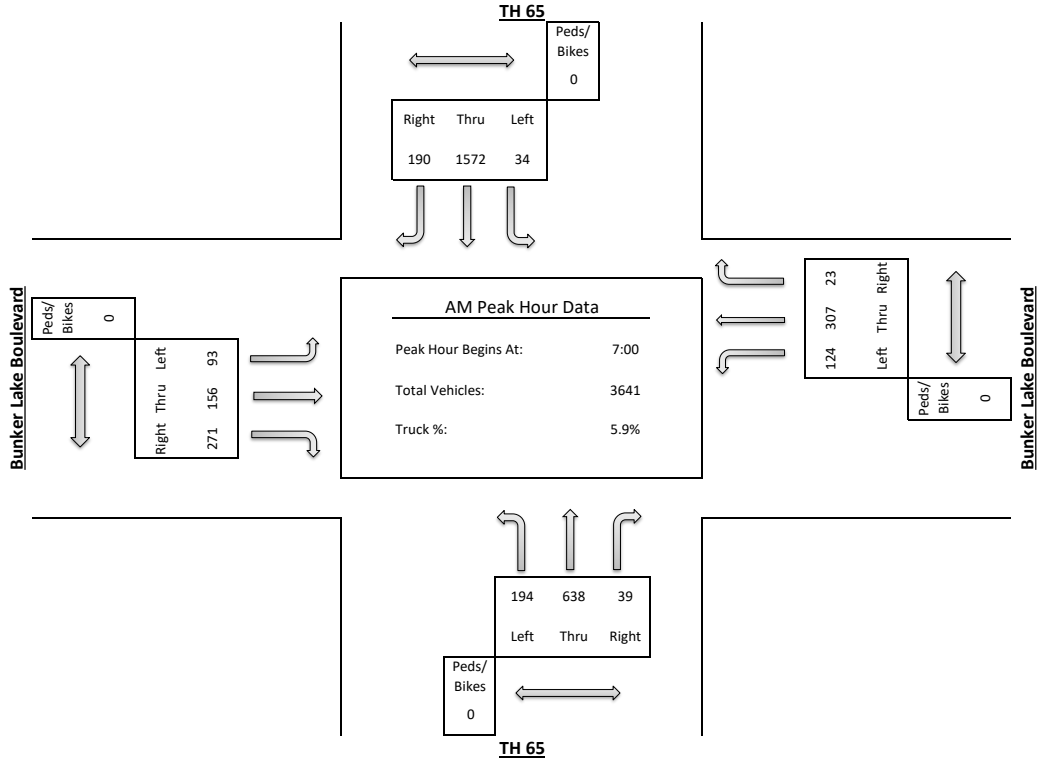

ALLIANT ENGINEERING, INC.

733 S Marquette Ave #700, Minneapolis, MN 55402

Intersection: TH 65 & Bunker Lake Boulevard
 Date: 12/17/2024
 Duration: 0600-1900

Site Code: 111
 Ref Pt: N/A
 Page No: 3 of 4

All Vehicles (Cars & Trucks) Printed

Start Time	TH 65 Southbound						Bunker Lake Boulevard Westbound						TH 65 Northbound						Bunker Lake Boulevard Eastbound						Int. Veh. Total	Int. Ped/Bike Total
	U-Turn	Left	Thru	Right	App. Total	Peds/Bikes	U-Turn	Left	Thru	Right	App. Total	Peds/Bikes	U-Turn	Left	Thru	Right	App. Total	Peds/Bikes	U-Turn	Left	Thru	Right	App. Total	Peds/Bikes		
12:30	--	9	248	20	277	--	--	33	37	11	81	--	--	34	257	24	315	--	--	26	31	39	96	--	769	--
12:45	--	11	247	26	284	--	--	39	31	11	81	--	1	56	257	25	339	--	--	27	28	40	95	--	799	--
13:00	--	--	222	15	237	--	--	27	29	11	67	--	4	41	279	28	352	--	--	20	25	44	89	--	745	--
13:15	--	6	245	19	270	--	--	20	30	8	58	--	3	53	261	18	335	--	--	14	30	53	97	--	760	--
Hour Total	--	26	962	80	1068	--	--	119	127	41	287	--	8	184	1054	95	1341	--	--	87	114	176	377	--	3073	--
% of App.	0.0%	2.4%	90.1%	7.5%			0.0%	41.5%	44.3%	14.3%			0.6%	13.7%	78.6%	7.1%			0.0%	23.1%	30.2%	46.7%				
% of Total	0.0%	0.8%	31.3%	2.6%	34.8%	--	0.0%	3.9%	4.1%	1.3%	9.3%	--	0.3%	6.0%	34.3%	3.1%	43.6%	--	0.0%	2.8%	3.7%	5.7%	12.3%	--		
Cars Total	--	25	868	76	969	--	--	117	123	39	279	--	8	175	959	91	1233	--	--	86	109	169	364	--	2845	--
Cars % of Movement	0.0%	96.2%	90.2%	95.0%	90.7%	--	0.0%	98.3%	96.9%	95.1%	97.2%	--	100%	95.1%	91.0%	95.8%	91.9%	--	0.0%	98.9%	95.6%	96.0%	96.6%	--	92.6%	--
Trucks Total	--	1	94	4	99	--	--	2	4	2	8	--	--	9	95	4	108	--	--	1	5	7	13	--	228	--
Trucks % of Movement	0.0%	3.8%	9.8%	5.0%	9.3%	--	0.0%	1.7%	3.1%	4.9%	2.8%	--	0.0%	4.9%	9.0%	4.2%	8.1%	--	0.0%	1.1%	4.4%	4.0%	3.4%	--	7.4%	--

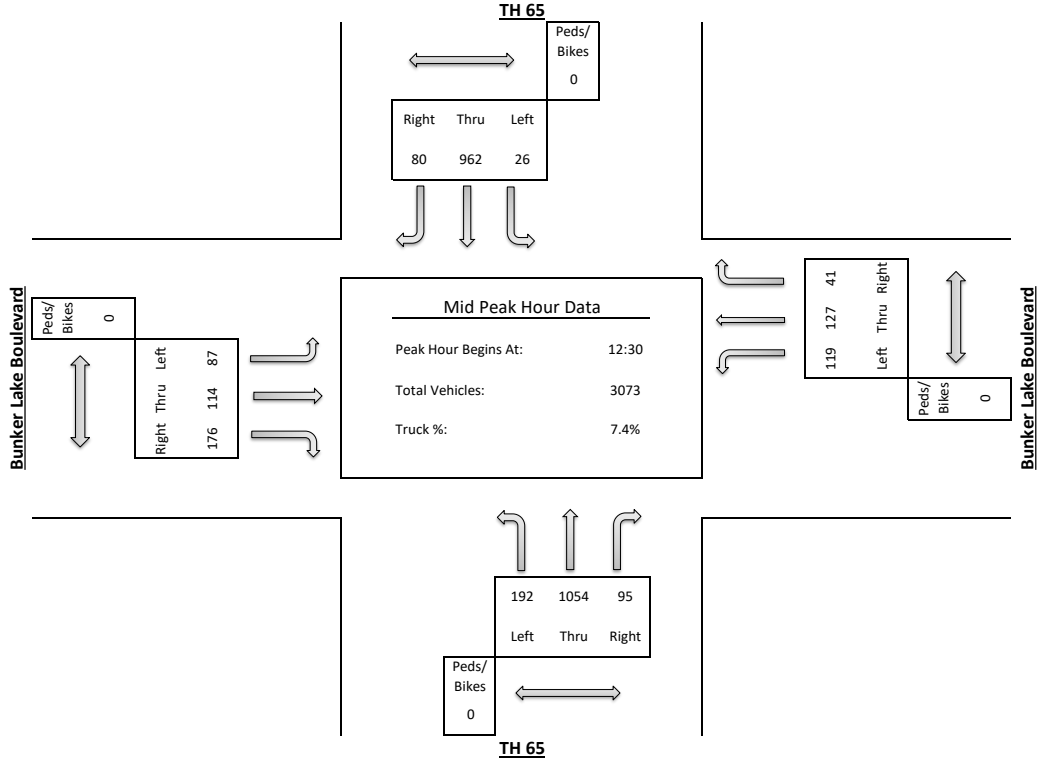

ALLIANT ENGINEERING, INC.

733 S Marquette Ave #700, Minneapolis, MN 55402

Intersection: TH 65 & Bunker Lake Boulevard
 Date: 12/17/2024
 Duration: 0600-1900

Site Code: 111
 Ref Pt: N/A
 Page No: 4 of 4

All Vehicles (Cars & Trucks) Printed

Start Time	TH 65 Southbound						Bunker Lake Boulevard Westbound						TH 65 Northbound						Bunker Lake Boulevard Eastbound						Int. Veh. Total	Int. Ped/Bike Total
	U-Turn	Left	Thru	Right	App. Total	Peds/Bikes	U-Turn	Left	Thru	Right	App. Total	Peds/Bikes	U-Turn	Left	Thru	Right	App. Total	Peds/Bikes	U-Turn	Left	Thru	Right	App. Total	Peds/Bikes		
16:15	--	9	214	32	255	--	--	31	69	32	132	--	5	81	398	52	536	--	--	41	69	64	174	--	1097	--
16:30	2	13	309	27	351	--	--	30	57	23	110	--	1	43	415	36	495	--	--	55	59	90	204	--	1160	--
16:45	--	11	247	23	281	--	--	28	68	20	116	--	2	74	400	36	512	--	--	41	58	49	148	--	1057	--
17:00	1	11	282	24	318	--	1	37	50	25	113	--	2	62	430	38	532	--	--	26	64	44	134	--	1097	--
Hour Total	3	44	1052	106	1205	--	1	126	244	100	471	--	10	260	1643	162	2075	--	--	163	250	247	660	--	4411	--
% of App.	0.2%	3.7%	87.3%	8.8%			0.2%	26.8%	51.8%	21.2%			0.5%	12.5%	79.2%	7.8%			0.0%	24.7%	37.9%	37.4%				
% of Total	0.1%	1.0%	23.8%	2.4%	27.3%	--	0.0%	2.9%	5.5%	2.3%	10.7%	--	0.2%	5.9%	37.2%	3.7%	47.0%	--	0.0%	3.7%	5.7%	5.6%	15.0%	--		
Cars Total	3	43	1031	102	1179	--	1	122	236	97	456	--	10	254	1594	160	2018	--	--	161	243	245	649	--	4302	--
Cars % of Movement	100%	97.7%	98.0%	96.2%	97.8%	--	100%	96.8%	96.7%	97.0%	96.8%	--	100%	97.7%	97.0%	98.8%	97.3%	--	0.0%	98.8%	97.2%	99.2%	98.3%	--	97.5%	--
Trucks Total	--	1	21	4	26	--	--	4	8	3	15	--	--	6	49	2	57	--	--	2	7	2	11	--	109	--
Trucks % of Movement	0.0%	2.3%	2.0%	3.8%	2.2%	--	0.0%	3.2%	3.3%	3.0%	3.2%	--	0.0%	2.3%	3.0%	1.2%	2.7%	--	0.0%	1.2%	2.8%	0.8%	1.7%	--	2.5%	--

