

Alliant Engineering

Minneapolis, MN 55415

--TRAFFIC DATA --

CSAH-56 at Dale Place / Richmond St E
 South St Paul
 data by Alliant Engineering
 TURN MOVEMENT COUNT

File Name : 508 - TH 156 and Dale-Richmond
 Site Code : 508
 Start Date : 3/19/2015
 Page No : 1

Groups Printed- Cars - Trucks

Start Time	CSAH-56 Southbound				Richmond St E Westbound				CSAH-56 Northbound				Dale Place Eastbound				Int. Total
	Left	Thru	Rght	Bikes	Left	Thru	Rght	Bikes	Left	Thru	Rght	Bikes	Left	Thru	Rght	Bikes	
06:00	5	32	1	0	1	0	1	0	2	69	2	0	11	1	0	0	125
06:15	8	40	2	2	4	0	5	0	1	86	12	0	11	0	2	0	173
06:30	17	42	4	6	1	0	6	0	2	114	13	0	17	0	2	0	224
06:45	18	47	5	7	1	3	7	0	0	79	18	0	6	1	3	0	195
Total	48	161	12	15	7	3	19	0	5	348	45	0	45	2	7	0	717
07:00	8	57	4	4	5	0	9	0	3	99	5	0	13	2	2	0	211
07:15	11	49	6	2	4	2	6	0	5	107	9	0	12	1	2	0	216
07:30	8	52	8	5	7	4	7	0	2	130	9	0	16	1	0	2	251
07:45	14	57	7	1	3	0	4	0	0	105	7	0	22	5	3	0	228
Total	41	215	25	12	19	6	26	0	10	441	30	0	63	9	7	2	906
08:00	7	48	7	2	4	2	9	0	3	93	4	0	5	3	2	0	189
08:15	11	49	8	4	3	3	6	0	2	86	4	0	15	1	2	0	194
08:30	15	46	5	4	3	2	10	2	7	75	7	0	15	1	3	0	195
08:45	18	42	5	2	9	1	4	0	5	62	9	0	19	4	8	0	188
Total	51	185	25	12	19	8	29	2	17	316	24	0	54	9	15	0	766
09:00	5	39	2	1	7	3	8	0	1	58	2	0	14	1	3	0	144
09:15	12	31	3	1	5	5	12	0	4	71	7	0	13	2	3	0	169
*** BREAK ***																	
Total	17	70	5	2	12	8	20	0	5	129	9	0	27	3	6	0	313
*** BREAK ***																	
10:30	9	55	1	3	9	0	12	1	1	56	9	1	11	2	0	0	170
10:45	7	56	3	0	2	0	6	0	1	56	5	0	12	0	1	0	149
Total	16	111	4	3	11	0	18	1	2	112	14	1	23	2	1	0	319
11:00	6	61	2	1	4	5	3	0	4	62	8	0	11	0	1	0	168
11:15	10	61	5	0	7	2	4	0	1	56	4	0	11	1	3	0	165
11:30	12	60	2	2	3	1	10	0	2	55	6	0	9	6	2	0	170
11:45	10	63	6	1	13	3	12	0	0	56	8	0	7	0	2	0	181
Total	38	245	15	4	27	11	29	0	7	229	26	0	38	7	8	0	684
12:00	12	76	6	2	8	3	11	0	4	60	5	0	5	3	2	0	197
12:15	12	73	8	5	15	4	10	0	2	65	17	0	7	4	1	0	223
12:30	20	78	5	2	6	3	10	1	2	78	4	0	19	0	0	0	228
12:45	13	61	9	9	2	3	10	0	8	67	7	0	11	2	4	0	206
Total	57	288	28	18	31	13	41	1	16	270	33	0	42	9	7	0	854
13:00	12	60	5	3	13	5	11	0	1	59	6	0	8	2	4	0	189
13:15	10	63	6	3	6	3	11	0	3	65	5	1	7	1	3	0	187
*** BREAK ***																	
Total	22	123	11	6	19	8	22	0	4	124	11	1	15	3	7	0	376
*** BREAK ***																	
14:30	13	115	3	3	10	6	11	0	1	99	4	0	12	5	7	0	289
14:45	18	89	11	1	13	8	5	0	6	65	7	0	9	3	2	0	237
Total	31	204	14	4	23	14	16	0	7	164	11	0	21	8	9	0	526
15:00	15	118	9	0	8	1	16	0	7	97	10	0	15	4	5	0	305
15:15	5	111	15	5	13	5	15	0	10	68	7	0	6	2	10	0	272
15:30	3	122	12	2	9	8	14	0	4	124	2	0	31	3	7	0	341
15:45	7	135	17	3	11	3	9	0	7	121	13	0	17	2	5	0	350
Total	30	486	53	10	41	17	54	0	28	410	32	0	69	11	27	0	1268
16:00	9	113	15	2	14	3	21	0	7	95	5	0	15	6	6	0	311
16:15	6	133	11	2	11	1	16	0	10	81	9	0	16	3	3	0	302
16:30	6	133	15	2	12	3	12	0	2	85	8	1	16	2	5	0	302

Alliant Engineering

Minneapolis, MN 55415

--TRAFFIC DATA --

CSAH-56 at Dale Place / Richmond St E
 South St Paul
 data by Alliant Engineering
 TURN MOVEMENT COUNT

File Name : 508 - TH 156 and Dale-Richmond
 Site Code : 508
 Start Date : 3/19/2015
 Page No : 2

Groups Printed- Cars - Trucks

Start Time	CSAH-56 Southbound				Richmond St E Westbound				CSAH-56 Northbound				Dale Place Eastbound				Int. Total
	Left	Thru	Rght	Bikes	Left	Thru	Rght	Bikes	Left	Thru	Rght	Bikes	Left	Thru	Rght	Bikes	
16:45	5	143	14	1	12	3	9	0	1	102	13	1	19	2	3	0	328
Total	26	522	55	7	49	10	58	0	20	363	35	2	66	13	17	0	1243
17:00	5	117	18	4	10	7	11	0	6	118	17	1	16	3	2	0	335
17:15	5	132	12	1	10	4	5	0	5	102	21	0	19	2	3	0	321
17:30	3	123	13	1	5	6	5	0	6	91	16	0	13	0	7	0	289
17:45	5	92	13	2	7	0	11	0	10	78	5	0	17	0	3	0	243
Total	18	464	56	8	32	17	32	0	27	389	59	1	65	5	15	0	1188
*** BREAK ***																	
Grand Total	395	3074	303	101	290	115	364	4	148	3295	329	5	528	81	126	2	9160
Apprch %	10.2	79.4	7.8	2.6	37.5	14.9	47.1	0.5	3.9	87.2	8.7	0.1	71.6	11	17.1	0.3	
Total %	4.3	33.6	3.3	1.1	3.2	1.3	4	0	1.6	36	3.6	0.1	5.8	0.9	1.4	0	
Cars	317	2882	293	93	264	105	305	4	144	3080	299	4	514	75	123	2	8504
% Cars	80.3	93.8	96.7	92.1	91	91.3	83.8	100	97.3	93.5	90.9	80	97.3	92.6	97.6	100	92.8
Trucks	78	192	10	8	26	10	59	0	4	215	30	1	14	6	3	0	656
% Trucks	19.7	6.2	3.3	7.9	9	8.7	16.2	0	2.7	6.5	9.1	20	2.7	7.4	2.4	0	7.2

Alliant Engineering

Minneapolis, MN 55415

--TRAFFIC DATA --

CSAH-56 at Dale Place / Richmond St E
 South St Paul
 data by Alliant Engineering
 TURN MOVEMENT COUNT

File Name : 508 - TH 156 and Dale-Richmond
 Site Code : 508
 Start Date : 3/19/2015
 Page No : 3

Start Time	CSAH-56 Southbound					Richmond St E Westbound					CSAH-56 Northbound					Dale Place Eastbound					Int. Total
	Left	Thru	Right	Bikes	App. Total	Left	Thru	Right	Bikes	App. Total	Left	Thru	Right	Bikes	App. Total	Left	Thru	Right	Bikes	App. Total	
Peak Hour Analysis From 06:00 to 11:45 - Peak 1 of 1																					
Peak Hour for Entire Intersection Begins at 07:00																					
07:00	8	57	4	4	73	5	0	9	0	14	3	99	5	0	107	13	2	2	0	17	211
07:15	11	49	6	2	68	4	2	6	0	12	5	107	9	0	121	12	1	2	0	15	216
07:30	8	52	8	5	73	7	4	7	0	18	2	130	9	0	141	16	1	0	2	19	251
07:45	14	57	7	1	79	3	0	4	0	7	0	105	7	0	112	22	5	3	0	30	228
Total Volume	41	215	25	12	293	19	6	26	0	51	10	441	30	0	481	63	9	7	2	81	906
% App. Total	14	73.4	8.5	4.1		37.3	11.8	51	0		2.1	91.7	6.2	0		77.8	11.1	8.6	2.5		
PHF	.732	.943	.781	.600	.927	.679	.375	.722	.000	.708	.500	.848	.833	.000	.853	.716	.450	.583	.250	.675	.902

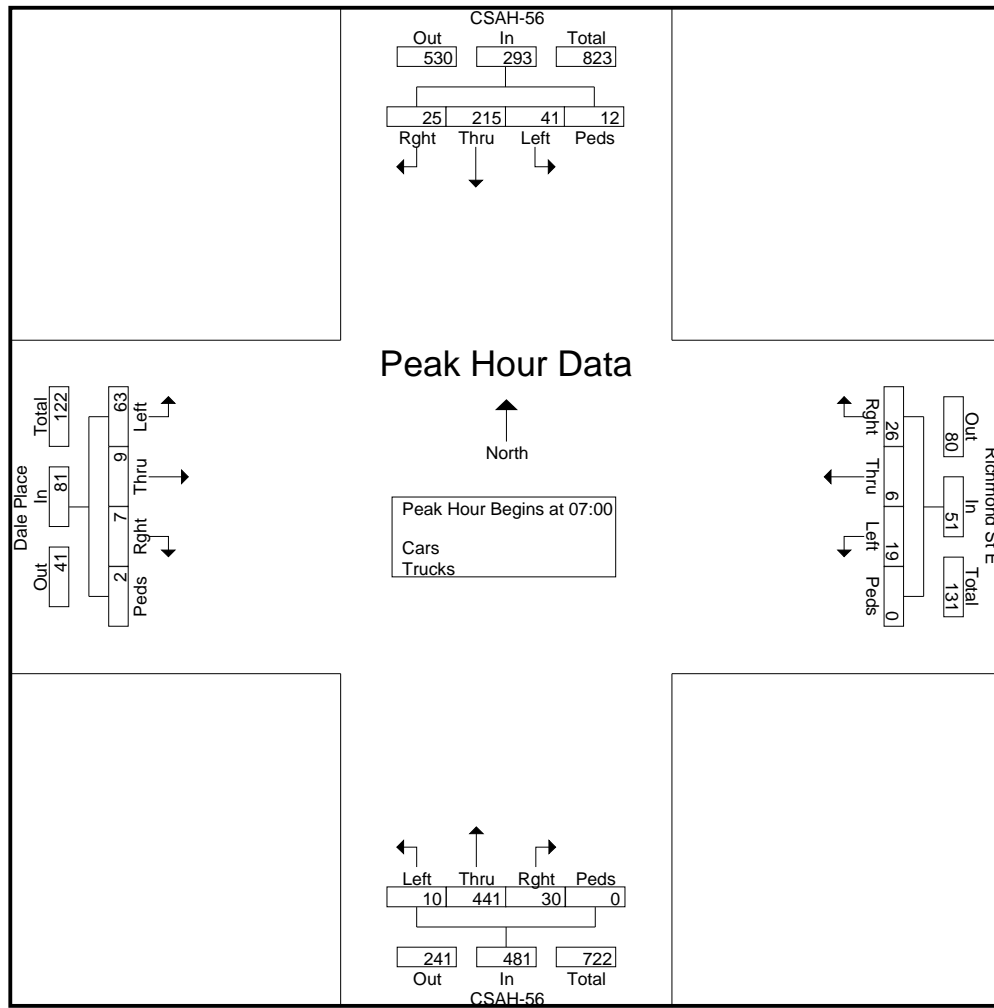

Alliant Engineering

Minneapolis, MN 55415

--TRAFFIC DATA --

CSAH-56 at Dale Place / Richmond St E
 South St Paul
 data by Alliant Engineering
 TURN MOVEMENT COUNT

File Name : 508 - TH 156 and Dale-Richmond
 Site Code : 508
 Start Date : 3/19/2015
 Page No : 4

Start Time	CSAH-56 Southbound					Richmond St E Westbound					CSAH-56 Northbound					Dale Place Eastbound					Int. Total
	Left	Thru	Rght	Bikes	App. Total	Left	Thru	Rght	Bikes	App. Total	Left	Thru	Rght	Bikes	App. Total	Left	Thru	Rght	Bikes	App. Total	
Peak Hour Analysis From 12:00 to 18:00 - Peak 1 of 1																					
Peak Hour for Entire Intersection Begins at 15:30																					
15:30	3	122	12	2	139	9	8	14	0	31	4	124	2	0	130	31	3	7	0	41	341
15:45	7	135	17	3	162	11	3	9	0	23	7	121	13	0	141	17	2	5	0	24	350
16:00	9	113	15	2	139	14	3	21	0	38	7	95	5	0	107	15	6	6	0	27	311
16:15	6	133	11	2	152	11	1	16	0	28	10	81	9	0	100	16	3	3	0	22	302
Total Volume	25	503	55	9	592	45	15	60	0	120	28	421	29	0	478	79	14	21	0	114	1304
% App. Total	4.2	85	9.3	1.5		37.5	12.5	50	0		5.9	88.1	6.1	0		69.3	12.3	18.4	0		
PHF	.694	.931	.809	.750	.914	.804	.469	.714	.000	.789	.700	.849	.558	.000	.848	.637	.583	.750	.000	.695	.931

