

Short Elliott Hendrickson Inc.

3535 Vadnais Center Drive
St. Paul, MN 55110

"Building a Better World for All of Us"



TRAFFIC DATA

I-94 & McKnight Rd S Ramp/Burns Ave
Ref.Pt.: 246.659
Data By: Short Elliott Hendrickson, Inc.
TURN MOVEMENT COUNT

File Name : I-94 & McKnight Rd S Ramp 2019
Site Code : 6b
Start Date : 4/30/2019
Page No : 1

Groups Printed- Vehicles - Trucks

Start Time	McKnight Rd Southbound					Burns Ave Westbound					McKnight Rd Northbound					Burns Ave Eastbound					Int. Total
	Left	Thru	Right	Peds	App. Total	Left	Thru	Right	Peds	App. Total	Left	Thru	Right	Peds	App. Total	Left	Thru	Right	Peds	App. Total	
06:00	15	24	4	0	43	0	0	2	0	2	0	70	5	0	75	11	4	2	0	17	137
06:15	24	54	4	0	82	0	0	2	0	2	2	99	8	0	109	7	2	2	0	11	204
06:30	23	68	9	0	100	1	1	5	0	7	5	97	9	0	111	7	7	4	0	18	236
06:45	30	94	16	0	140	0	0	10	0	10	12	130	12	0	154	10	7	2	0	19	323
Total	92	240	33	0	365	1	1	19	0	21	19	396	34	0	449	35	20	10	0	65	900
07:00	31	89	22	0	142	0	0	8	0	8	8	165	14	0	187	11	13	8	0	32	369
07:15	36	74	38	0	148	0	5	4	0	9	15	179	19	1	214	24	12	5	0	41	412
07:30	40	80	37	0	157	1	2	4	0	7	20	192	25	0	237	38	18	5	0	61	462
07:45	33	96	35	0	164	0	1	3	0	4	19	188	7	0	214	17	12	11	0	40	422
Total	140	339	132	0	611	1	8	19	0	28	62	724	65	1	852	90	55	29	0	174	1665
08:00	30	92	31	0	153	2	3	3	0	8	22	138	12	0	172	12	12	13	0	37	370
08:15	34	65	17	0	116	0	1	5	0	6	10	147	18	0	175	11	18	4	1	34	331
08:30	19	64	11	0	94	0	0	7	1	8	13	111	20	0	144	13	12	9	0	34	280
08:45	44	76	16	0	136	0	1	3	0	4	6	117	14	0	137	13	13	8	0	34	311
Total	127	297	75	0	499	2	5	18	1	26	51	513	64	0	628	49	55	34	1	139	1292
09:00	26	74	13	0	113	0	0	5	0	5	9	112	14	0	135	13	8	4	0	25	278
09:15	32	58	13	0	103	0	2	7	0	9	2	103	11	0	116	6	8	7	0	21	249
09:30	27	57	13	0	97	0	0	4	0	4	2	86	13	0	101	5	13	1	0	19	221
09:45	38	56	20	0	114	0	1	5	0	6	7	55	2	0	64	10	12	4	0	26	210
Total	123	245	59	0	427	0	3	21	0	24	20	356	40	0	416	34	41	16	0	91	958
10:00	27	65	8	0	100	0	0	4	0	4	5	77	13	0	95	4	6	4	1	15	214
10:15	34	61	17	0	112	0	0	2	0	2	8	70	12	0	90	7	8	5	0	20	224
10:30	31	50	9	0	90	0	0	1	0	1	4	64	13	0	81	6	20	6	0	32	204
10:45	32	61	27	0	120	0	0	1	0	1	8	63	13	0	84	7	8	2	0	17	222
Total	124	237	61	0	422	0	0	8	0	8	25	274	51	0	350	24	42	17	1	84	864
11:00	46	72	20	0	138	1	0	0	0	1	10	69	21	0	100	8	13	9	0	30	269
11:15	44	68	26	0	138	0	1	0	0	1	7	67	4	0	78	16	17	9	1	43	260
11:30	65	80	22	0	167	1	0	1	0	2	6	69	7	0	82	10	13	9	0	32	283
11:45	34	86	15	0	135	0	1	2	0	3	10	81	11	0	102	16	15	7	0	38	278
Total	189	306	83	0	578	2	2	3	0	7	33	286	43	0	362	50	58	34	1	143	1090
12:00	51	77	25	0	153	0	1	4	0	5	8	77	10	0	95	12	10	13	0	35	288
12:15	33	83	20	0	136	2	3	4	0	9	4	75	13	0	92	7	22	5	0	34	271
12:30	47	85	17	0	149	0	1	2	1	4	9	74	13	0	96	17	17	4	0	38	287
12:45	54	67	13	0	134	0	0	2	0	2	5	72	8	0	85	10	17	11	0	38	259
Total	185	312	75	0	572	2	5	12	1	20	26	298	44	0	368	46	66	33	0	145	1105
13:00	51	85	28	0	164	0	0	4	1	5	8	69	16	0	93	21	13	9	0	43	305
13:15	38	53	24	0	115	0	0	2	0	2	9	73	12	0	94	13	17	7	0	37	248
13:30	27	83	24	0	134	1	0	0	0	1	7	69	10	0	86	8	13	8	0	29	250
13:45	40	92	14	0	146	0	2	3	0	5	2	88	25	0	115	8	13	5	0	26	292
Total	156	313	90	0	559	1	2	9	1	13	26	299	63	0	388	50	56	29	0	135	1095

Short Elliott Hendrickson Inc.

3535 Vadnais Center Drive
St. Paul, MN 55110

"Building a Better World for All of Us"



TRAFFIC DATA

I-94 & McKnight Rd S Ramp/Burns Ave
Ref.Pt.: 246.659
Data By: Short Elliott Hendrickson, Inc.
TURN MOVEMENT COUNT

File Name : I-94 & McKnight Rd S Ramp 2019
Site Code : 6b
Start Date : 4/30/2019
Page No : 2

Groups Printed- Vehicles - Trucks

Start Time	McKnight Rd Southbound					Burns Ave Westbound					McKnight Rd Northbound					Burns Ave Eastbound					Int. Total
	Left	Thru	Right	Peds	App. Total	Left	Thru	Right	Peds	App. Total	Left	Thru	Right	Peds	App. Total	Left	Thru	Right	Peds	App. Total	
14:00	45	80	14	0	139	0	2	3	0	5	7	83	19	0	109	16	13	13	0	42	295
14:15	40	96	15	0	151	0	0	1	0	1	2	71	15	0	88	16	10	4	0	30	270
14:30	46	106	28	0	180	0	1	3	0	4	6	100	13	0	119	4	18	10	1	33	336
14:45	52	89	21	0	162	1	0	3	0	4	5	86	20	0	111	7	23	7	0	37	314
Total	183	371	78	0	632	1	3	10	0	14	20	340	67	0	427	43	64	34	1	142	1215
15:00	78	120	23	0	221	0	0	7	0	7	8	85	17	0	110	6	21	10	0	37	375
15:15	90	151	26	0	267	0	2	2	0	4	6	100	12	0	118	9	13	10	0	32	421
15:30	74	131	19	0	224	1	0	6	0	7	11	108	14	0	133	8	21	9	0	38	402
15:45	78	117	20	0	215	1	0	4	0	5	16	101	13	0	130	16	22	10	0	48	398
Total	320	519	88	0	927	2	2	19	0	23	41	394	56	0	491	39	77	39	0	155	1596
16:00	96	143	26	0	265	0	0	0	0	0	12	118	15	0	145	21	26	10	0	57	467
16:15	124	165	35	0	324	1	1	9	0	11	11	100	18	0	129	8	14	21	0	43	507
16:30	104	152	26	0	282	0	0	3	0	3	15	137	13	0	165	12	21	19	0	52	502
16:45	95	162	30	0	287	0	2	4	0	6	8	142	7	0	157	10	21	10	0	41	491
Total	419	622	117	0	1158	1	3	16	0	20	46	497	53	0	596	51	82	60	0	193	1967
17:00	94	181	32	0	307	1	2	3	0	6	14	129	17	0	160	12	21	16	0	49	522
17:15	106	171	45	0	322	0	2	7	0	9	13	113	13	0	139	17	15	8	1	41	511
17:30	84	172	23	0	279	0	1	3	0	4	14	120	14	0	148	10	18	14	0	42	473
17:45	81	139	28	0	248	0	0	4	0	4	14	93	16	0	123	8	21	13	0	42	417
Total	365	663	128	0	1156	1	5	17	0	23	55	455	60	0	570	47	75	51	1	174	1923
18:00	61	145	33	0	239	0	2	0	0	2	6	112	13	0	131	14	23	16	0	53	425
18:15	47	125	28	0	200	0	0	1	0	1	12	80	11	0	103	7	26	10	0	43	347
18:30	48	104	19	0	171	0	0	3	0	3	10	63	24	2	99	8	16	9	2	35	308
18:45	44	102	19	0	165	0	0	2	0	2	2	59	9	1	71	7	11	8	0	26	264
Total	200	476	99	0	775	0	2	6	0	8	30	314	57	3	404	36	76	43	2	157	1344
Grand Total	2623	4940	1118	0	8681	14	41	177	3	235	454	5146	697	4	6301	594	767	429	7	1797	17014
Apprch %	30.2	56.9	12.9	0		6	17.4	75.3	1.3		7.2	81.7	11.1	0.1		33.1	42.7	23.9	0.4		
Total %	15.4	29	6.6	0	51	0.1	0.2	1	0	1.4	2.7	30.2	4.1	0	37	3.5	4.5	2.5	0	10.6	
Vehicles	2570	4731	1078									4988									16468
% Vehicles	98	95.8	96.4	0	96.5	85.7	85.4	96	66.7	93.2	98	96.9	98.7	100	97.2	97.1	98.3	95.1	85.7	97.1	96.8
Trucks	53	209	40	0	302	2	6	7	1	16	9	158	9	0	176	17	13	21	1	52	546
% Trucks	2	4.2	3.6	0	3.5	14.3	14.6	4	33.3	6.8	2	3.1	1.3	0	2.8	2.9	1.7	4.9	14.3	2.9	3.2

Short Elliott Hendrickson Inc.

3535 Vadnais Center Drive
St. Paul, MN 55110

"Building a Better World for All of Us"



TRAFFIC DATA

I-94 & McKnight Rd S Ramp/Burns Ave
Ref.Pt.: 246.659
Data By: Short Elliott Hendrickson, Inc.
TURN MOVEMENT COUNT

File Name : I-94 & McKnight Rd S Ramp 2019
Site Code : 6b
Start Date : 4/30/2019
Page No : 3

Start Time	McKnight Rd Southbound					Burns Ave Westbound					McKnight Rd Northbound					Burns Ave Eastbound					Int. Total
	Left	Thru	Right	Peds	App. Total	Left	Thru	Right	Peds	App. Total	Left	Thru	Right	Peds	App. Total	Left	Thru	Right	Peds	App. Total	
Peak Hour Analysis From 06:00 to 08:45 - Peak 1 of 1 Peak Hour for Entire Intersection Begins at 07:15																					
07:15	36	74	38	0	148	0	5	4	0	9	15	179	19	1	214	24	12	5	0	41	412
07:30	40	80	37	0	157	1	2	4	0	7	20	192	25	0	237	38	18	5	0	61	462
07:45	33	96	35	0	164	0	1	3	0	4	19	188	7	0	214	17	12	11	0	40	422
08:00	30	92	31	0	153	2	3	3	0	8	22	138	12	0	172	12	12	13	0	37	370
Total Volume	139	342	141	0	622	3	11	14	0	28	76	697	63	1	837	91	54	34	0	179	1666
% App. Total	22.3	55	22.7	0		10.7	39.3	50	0		9.1	83.3	7.5	0.1		50.8	30.2	19	0		
PHF	.869	.891	.928	.000	.948	.375	.550	.875	.000	.778	.864	.908	.630	.250	.883	.599	.750	.654	.000	.734	.902

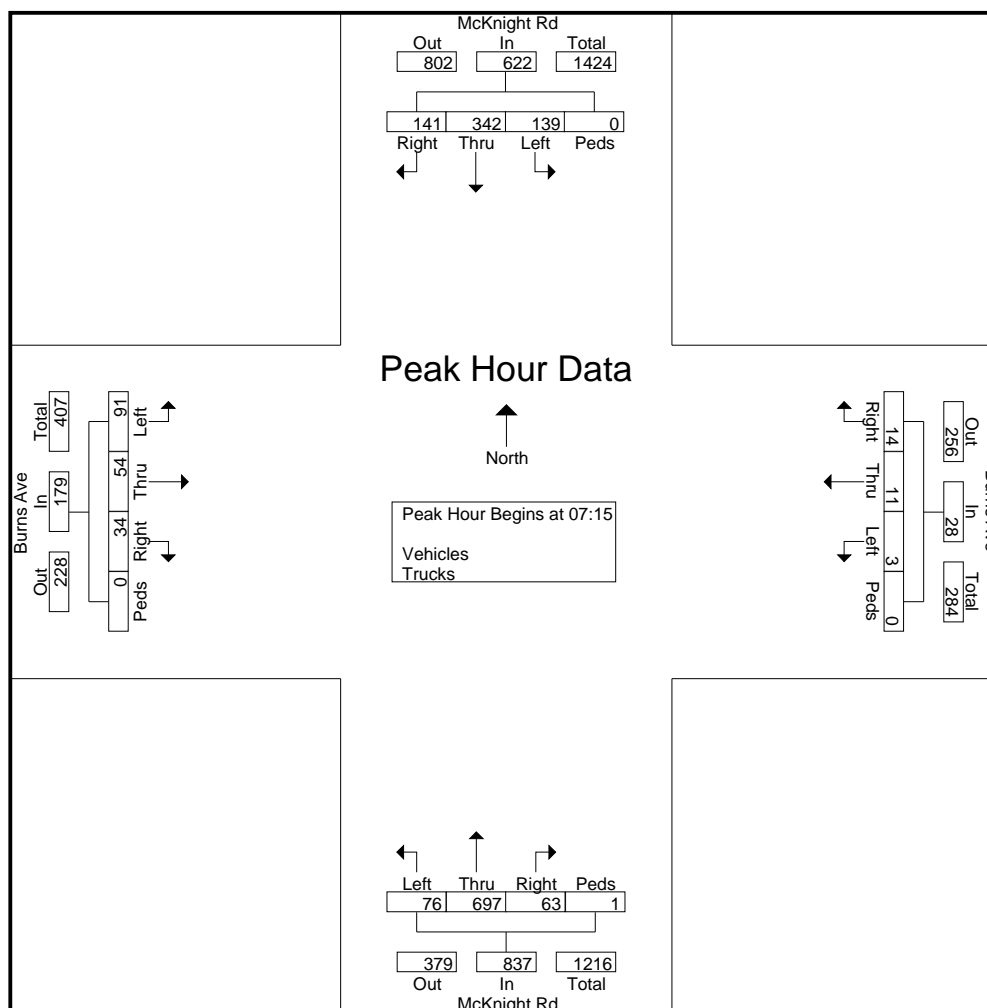

Short Elliott Hendrickson Inc.

3535 Vadnais Center Drive
St. Paul, MN 55110

"Building a Better World for All of Us"



TRAFFIC DATA

I-94 & McKnight Rd S Ramp/Burns Ave
Ref.Pt.: 246.659
Data By: Short Elliott Hendrickson, Inc.
TURN MOVEMENT COUNT

File Name : I-94 & McKnight Rd S Ramp 2019
Site Code : 6b
Start Date : 4/30/2019
Page No : 4

Start Time	McKnight Rd Southbound					Burns Ave Westbound					McKnight Rd Northbound					Burns Ave Eastbound					Int. Total
	Left	Thru	Right	Peds	App. Total	Left	Thru	Right	Peds	App. Total	Left	Thru	Right	Peds	App. Total	Left	Thru	Right	Peds	App. Total	
Peak Hour Analysis From 11:00 to 12:45 - Peak 1 of 1 Peak Hour for Entire Intersection Begins at 11:45																					
11:45	34	86	15	0	135	0	1	2	0	3	10	81	11	0	102	16	15	7	0	38	278
12:00	51	77	25	0	153	0	1	4	0	5	8	77	10	0	95	12	10	13	0	35	288
12:15	33	83	20	0	136	2	3	4	0	9	4	75	13	0	92	7	22	5	0	34	271
12:30	47	85	17	0	149	0	1	2	1	4	9	74	13	0	96	17	17	4	0	38	287
Total Volume	165	331	77	0	573	2	6	12	1	21	31	307	47	0	385	52	64	29	0	145	1124
% App. Total	28.8	57.8	13.4	0		9.5	28.6	57.1	4.8		8.1	79.7	12.2	0		35.9	44.1	20	0		
PHF	.809	.962	.770	.000	.936	.250	.500	.750	.250	.583	.775	.948	.904	.000	.944	.765	.727	.558	.000	.954	.976

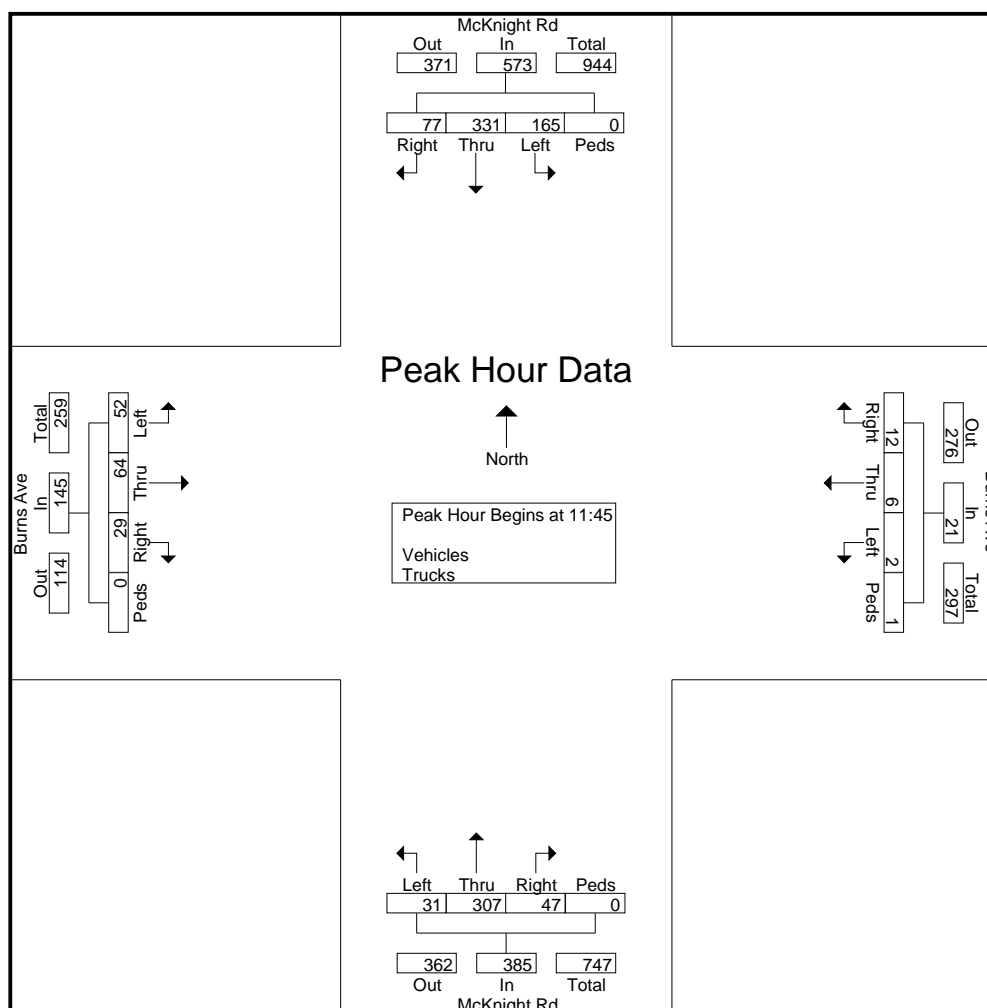

Short Elliott Hendrickson Inc.

3535 Vadnais Center Drive
St. Paul, MN 55110

"Building a Better World for All of Us"



TRAFFIC DATA

I-94 & McKnight Rd S Ramp/Burns Ave
Ref.Pt.: 246.659
Data By: Short Elliott Hendrickson, Inc.
TURN MOVEMENT COUNT

File Name : I-94 & McKnight Rd S Ramp 2019
Site Code : 6b
Start Date : 4/30/2019
Page No : 5

Start Time	McKnight Rd Southbound					Burns Ave Westbound					McKnight Rd Northbound					Burns Ave Eastbound					Int. Total
	Left	Thru	Right	Peds	App. Total	Left	Thru	Right	Peds	App. Total	Left	Thru	Right	Peds	App. Total	Left	Thru	Right	Peds	App. Total	
Peak Hour Analysis From 15:00 to 17:45 - Peak 1 of 1 Peak Hour for Entire Intersection Begins at 16:30																					
16:30	104	152	26	0	282	0	0	3	0	3	15	137	13	0	165	12	21	19	0	52	502
16:45	95	162	30	0	287	0	2	4	0	6	8	142	7	0	157	10	21	10	0	41	491
17:00	94	181	32	0	307	1	2	3	0	6	14	129	17	0	160	12	21	16	0	49	522
17:15	106	171	45	0	322	0	2	7	0	9	13	113	13	0	139	17	15	8	1	41	511
Total Volume	399	666	133	0	1198	1	6	17	0	24	50	521	50	0	621	51	78	53	1	183	2026
% App. Total	33.3	55.6	11.1	0		4.2	25	70.8	0		8.1	83.9	8.1	0		27.9	42.6	29	0.5		
PHF	.941	.920	.739	.000	.930	.250	.750	.607	.000	.667	.833	.917	.735	.000	.941	.750	.929	.697	.250	.880	.970

