



# MINNESOTA DEPT OF TRANSPORTATION

## TRAFFIC DATA COLLECTION - METRO

TH-13 at 152nd St / Green Oaks Trail SE  
 Ref.Pt.; 086.898 PRIOR LAKE  
 video JI  
 TURN MOVEMENT COUNT

File Name : TH-13 at 152nd St 2013  
 Site Code :  
 Start Date : 11/13/2013  
 Page No : 1

Groups Printed- Cars +

Start Time	TH-13 Southbound				152nd St. Westbound				TH-13 Northbound				Green Oaks Trail SE Eastbound				Int. Total	
	Right	Thru	Left	Peds	Right	Thru	Left	Peds	Right	Thru	Left	Peds	Right	Thru	Left	Peds		
06:00	2	16	0	0	2	0	2	0	0	108	0	0	0	0	0	1	0	131
06:15	0	35	0	0	4	0	0	0	0	140	0	0	0	0	0	1	0	180
06:30	0	59	1	0	4	0	0	0	0	165	0	0	0	0	2	0	0	231
06:45	0	99	0	0	1	0	5	0	1	238	0	0	0	0	4	0	0	348
Total	2	209	1	0	11	0	7	0	1	651	0	0	0	0	8	0	0	890
07:00	1	97	2	0	2	0	1	0	0	261	0	0	1	0	6	0	0	371
07:15	1	84	1	0	2	0	4	0	1	310	1	0	1	0	3	0	0	408
07:30	3	74	1	0	1	1	6	0	0	239	0	0	0	0	5	0	0	330
07:45	0	102	4	0	3	0	7	0	2	275	2	0	2	0	8	0	0	405
Total	5	357	8	0	8	1	18	0	3	1085	3	0	4	0	22	0	0	1514
08:00	2	85	0	0	2	1	8	0	2	193	1	0	3	3	7	0	0	307
08:15	3	104	0	0	3	1	10	0	3	205	2	0	2	0	1	0	0	334
08:30	2	91	0	0	1	0	3	0	2	176	1	0	1	0	2	0	0	279
08:45	0	71	0	0	1	0	2	0	0	140	2	0	2	0	2	0	0	220
Total	7	351	0	0	7	2	23	0	7	714	6	0	8	3	12	0	0	1140
***** BREAK *****																		
15:00	1	188	0	0	1	0	4	0	2	184	0	0	1	0	3	0	0	384
15:15	1	199	1	0	3	1	5	0	6	162	0	0	3	0	1	0	0	382
15:30	0	211	0	0	2	0	1	0	5	192	2	0	0	0	1	0	0	414
15:45	4	207	1	0	2	1	7	0	2	174	2	0	1	0	5	0	0	406
Total	6	805	2	0	8	2	17	0	15	712	4	0	5	0	10	0	0	1586
16:00	3	187	2	0	4	0	3	0	1	156	2	0	1	0	0	0	0	359
16:15	2	220	1	0	2	0	3	0	3	149	3	0	2	0	2	0	0	387
16:30	2	220	2	0	1	0	4	0	1	169	1	0	0	0	0	0	0	400
16:45	5	196	0	0	0	0	4	0	4	126	1	0	2	1	4	0	0	343
Total	12	823	5	0	7	0	14	0	9	600	7	0	5	1	6	0	0	1489
17:00	2	234	1	0	1	1	1	0	1	168	1	0	1	0	4	0	0	415
17:15	2	212	2	0	2	0	3	0	2	180	1	0	2	1	2	0	0	409
17:30	0	211	0	0	3	0	6	0	3	143	0	0	5	0	1	0	0	372
17:45	0	216	3	0	1	0	3	0	0	128	1	0	2	0	0	0	0	354
Total	4	873	6	0	7	1	13	0	6	619	3	0	10	1	7	0	0	1550
Grand Total	36	3418	22	0	48	6	92	0	41	4381	23	0	32	5	65	0	0	8169
Apprch %	1	98.3	0.6	0	32.9	4.1	63	0	0.9	98.6	0.5	0	31.4	4.9	63.7	0	0	
Total %	0.4	41.8	0.3	0	0.6	0.1	1.1	0	0.5	53.6	0.3	0	0.4	0.1	0.8	0	0	



# MINNESOTA DEPT OF TRANSPORTATION

## TRAFFIC DATA COLLECTION - METRO

TH-13 at 152nd St / Green Oaks Trail SE  
 Ref.Pt.; 086.898 PRIOR LAKE  
 video JI  
 TURN MOVEMENT COUNT

File Name : TH-13 at 152nd St 2013  
 Site Code :  
 Start Date : 11/13/2013  
 Page No : 2

Start Time	TH-13 Southbound					152nd St. Westbound					TH-13 Northbound					Green Oaks Trail SE Eastbound					Int. Total
	Right	Thru	Left	Peds	App. Total	Right	Thru	Left	Peds	App. Total	Right	Thru	Left	Peds	App. Total	Right	Thru	Left	Peds	App. Total	
Peak Hour Analysis From 06:00 to 08:45 - Peak 1 of 1																					
Peak Hour for Entire Intersection Begins at 07:00																					
07:00	1	97	2	0	100	2	0	1	0	3	0	261	0	0	261	1	0	6	0	7	371
07:15	1	84	1	0	86	2	0	4	0	6	1	<b>310</b>	1	0	<b>312</b>	1	0	3	0	4	<b>408</b>
07:30	3	74	1	0	78	1	1	6	0	8	0	239	0	0	239	0	0	5	0	5	330
07:45	0	<b>102</b>	<b>4</b>	0	<b>106</b>	<b>3</b>	0	<b>7</b>	0	<b>10</b>	<b>2</b>	275	<b>2</b>	0	279	<b>2</b>	0	<b>8</b>	0	<b>10</b>	405
Total Volume	5	357	8	0	370	8	1	18	0	27	3	1085	3	0	1091	4	0	22	0	26	1514
% App. Total	1.4	96.5	2.2	0		29.6	3.7	66.7	0		0.3	99.5	0.3	0		15.4	0	84.6	0		
PHF	.417	.875	.500	.000	.873	.667	.250	.643	.000	.675	.375	.875	.375	.000	.874	.500	.000	.688	.000	.650	.928

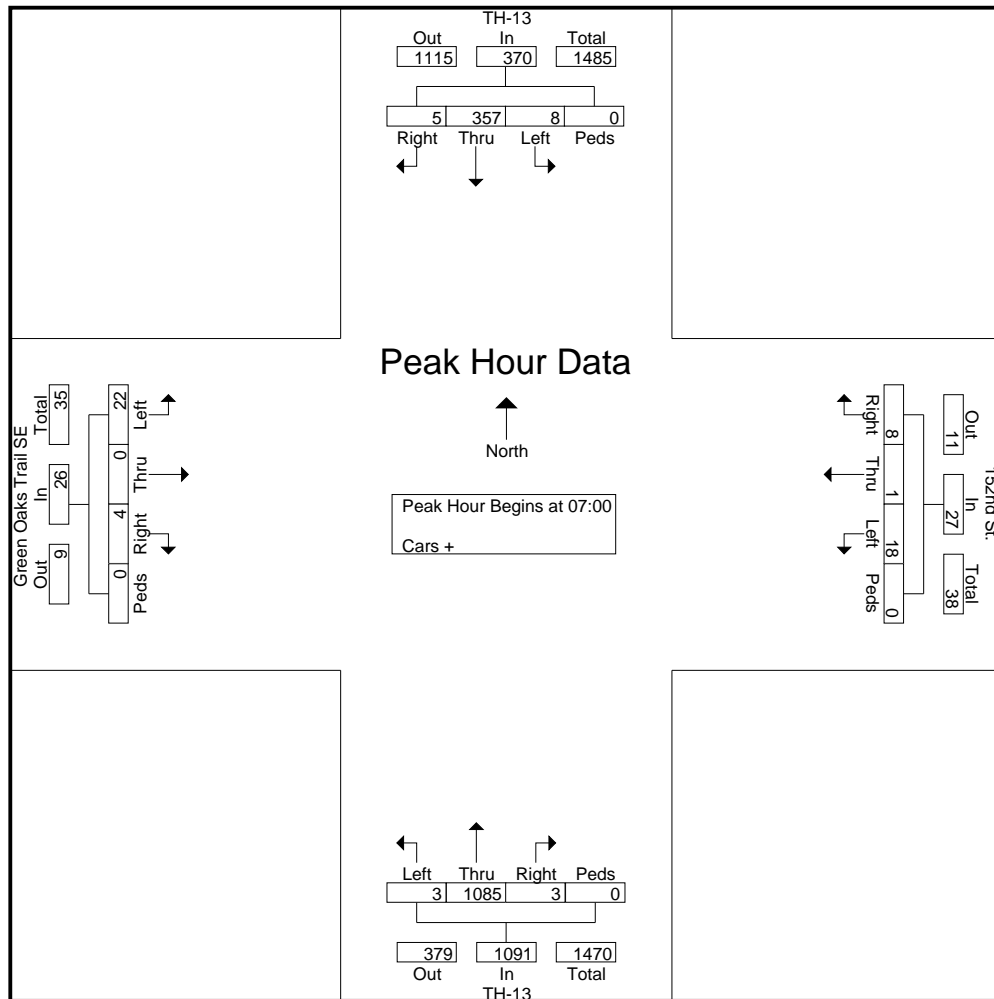



# MINNESOTA DEPT OF TRANSPORTATION

TRAFFIC DATA COLLECTION - METRO

TH-13 at 152nd St / Green Oaks Trail SE  
 Ref.Pt.; 086.898 PRIOR LAKE  
 video JI  
 TURN MOVEMENT COUNT

File Name : TH-13 at 152nd St 2013  
 Site Code :  
 Start Date : 11/13/2013  
 Page No : 3

Start Time	TH-13 Southbound					152nd St. Westbound					TH-13 Northbound					Green Oaks Trail SE Eastbound					Int. Total
	Rig ht	Thr u	Left	Ped s	App. Total	Rig ht	Thr u	Left	Ped s	App. Total	Right	Thr u	Left	Peds	App. Total	Right	Thr u	Left	Peds	App. Total	
15:00	1	188	0	0	189	1	0	4	0	5	2	184	0	0	186	1	0	3	0	4	384
15:15	1	199	1	0	201	3	1	5	0	9	6	162	0	0	168	3	0	1	0	4	382
15:30	0	211	0	0	211	2	0	1	0	3	5	192	2	0	199	0	0	1	0	1	414
15:45	4	207	1	0	212	2	1	7	0	10	2	174	2	0	178	1	0	5	0	6	406
Total Volume	6	805	2	0	813	8	2	17	0	27	15	712	4	0	731	5	0	10	0	15	1586
% App. Total	0.7	99	0.2	0		29.6	7.4	63	0		2.1	97.4	0.5	0		33.3	0	66.7	0		
PHF	.375	.954	.500	.000	.959	.667	.500	.607	.000	.675	.625	.927	.500	.000	.918	.417	.000	.500	.000	.625	.958

Peak Hour Analysis From 15:00 to 17:45 - Peak 1 of 1  
 Peak Hour for Entire Intersection Begins at 15:00

