

Alliant Engineering Inc Minneapolis, MN 55415

TH-149 at NW Pkwy / Blue Gentian Rd
Ref.Pt.: 003.761
Alliant Engineering Inc
TURN MOVEMENT COUNT

File Name : 15_TH 149 at Northwest Pkwy-Blue Gentian_021810
Site Code : 00000015
Start Date : 2/18/2010
Page No : 1

Groups Printed- Unshifted - Bank 1

Start Time	TH-149 / Dodd Rd Southbound				Northwest Parkway Westbound				TH-149 / Dodd Rd Northbound				Blue Gentian Rd Eastbound				Int. Total
	Left	Thru	Right	Peds	Left	Thru	Right	Peds	Left	Thru	Right	Peds	Left	Thru	Right	Peds	
06:00	0	0	0	0	3	1	5	0	16	131	15	0	0	0	0	0	171
06:15	10	52	7	0	1	1	0	0	11	140	7	0	1	0	1	0	231
06:30	24	172	23	0	0	0	2	0	2	115	0	0	5	0	0	0	343
06:45	39	213	59	0	0	2	4	0	1	115	2	0	5	1	0	0	441
Total	73	437	89	0	4	4	11	0	30	501	24	0	11	1	1	0	1186
07:00	40	198	47	0	1	1	12	0	3	125	0	0	6	2	0	0	435
07:15	46	248	74	0	0	1	6	0	6	152	1	0	5	1	0	0	540
07:30	36	264	45	2	1	1	2	3	6	177	2	0	8	3	7	0	557
07:45	50	305	80	0	1	2	1	0	4	149	1	0	7	3	2	0	605
Total	172	1015	246	2	3	5	21	3	19	603	4	0	26	9	9	0	2137
08:00	80	235	57	0	5	1	4	0	5	114	1	0	11	3	3	0	519
08:15	40	211	53	0	2	3	3	0	6	128	1	0	8	3	4	0	462
08:30	29	197	42	0	1	3	0	0	5	117	5	0	0	0	0	0	399
08:45	29	191	34	0	1	1	5	0	9	91	3	0	0	0	0	0	364
Total	178	834	186	0	9	8	12	0	25	450	10	0	19	6	7	0	1744
09:00	33	140	32	0	0	0	2	0	19	65	8	0	0	0	0	0	299
09:15	20	123	24	0	1	2	3	0	9	82	8	0	0	0	0	0	272
*** BREAK ***																	
Total	53	263	56	0	1	2	5	0	28	147	16	0	0	0	0	0	571
*** BREAK ***																	
10:30	7	49	10	0	1	3	5	0	1	89	5	0	13	0	5	0	188
10:45	6	79	23	0	1	1	12	0	5	86	2	0	12	1	6	0	234
Total	13	128	33	0	2	4	17	0	6	175	7	0	25	1	11	0	422
11:00	3	81	12	0	0	1	8	0	2	93	0	0	24	0	5	1	230
11:15	7	64	16	0	2	1	8	0	1	86	2	0	21	0	3	0	211
11:30	9	68	18	0	1	0	11	0	3	132	5	0	21	1	7	0	276
11:45	10	81	23	0	1	1	2	0	3	102	0	0	46	2	11	0	282
Total	29	294	69	0	4	3	29	0	9	413	7	0	112	3	26	1	999
12:00	11	95	17	1	1	0	11	0	3	123	2	0	41	1	9	0	315
12:15	24	65	21	0	2	2	5	0	5	102	1	0	27	1	8	0	263
12:30	11	86	24	0	0	1	10	0	1	119	1	0	18	4	17	0	292
12:45	9	93	20	0	2	1	10	0	6	97	1	0	16	2	5	0	262
Total	55	339	82	1	5	4	36	0	15	441	5	0	102	8	39	0	1132
13:00	5	101	25	0	1	1	5	0	3	60	1	0	11	3	7	0	223
13:15	15	87	17	0	2	0	3	0	5	98	3	0	15	2	3	0	250
*** BREAK ***																	
Total	20	188	42	0	3	1	8	0	8	158	4	0	26	5	10	0	473
*** BREAK ***																	
14:30	8	73	4	0	2	2	49	0	3	164	2	0	27	0	7	0	341
14:45	5	93	12	0	3	0	20	0	0	158	1	0	32	0	2	0	326
Total	13	166	16	0	5	2	69	0	3	322	3	0	59	0	9	0	667
15:00	7	91	12	0	3	2	49	0	7	205	1	0	12	1	6	0	396
15:15	7	96	26	0	3	2	29	0	0	201	0	0	13	0	2	0	379
15:30	2	76	13	0	1	4	42	0	1	245	1	0	66	1	5	0	457
15:45	9	81	17	0	3	2	35	0	3	201	1	0	42	0	2	0	396
Total	25	344	68	0	10	10	155	0	11	852	3	0	133	2	15	0	1628

Alliant Engineering Inc Minneapolis, MN 55415

TH-149 at NW Pkwy / Blue Gentian Rd
Ref.Pt.: 003.761
Alliant Engineering Inc
TURN MOVEMENT COUNT

File Name : 15_TH 149 at Northwest Pkwy-Blue Gentian_021810
Site Code : 00000015
Start Date : 2/18/2010
Page No : 2

Groups Printed- Unshifted - Bank 1

Start Time	TH-149 / Dodd Rd Southbound				Northwest Parkway Westbound				TH-149 / Dodd Rd Northbound				Blue Gentian Rd Eastbound				Int. Total
	Left	Thru	Right	Peds	Left	Thru	Right	Peds	Left	Thru	Right	Peds	Left	Thru	Right	Peds	
16:00	32	57	10	0	4	37	33	0	4	277	0	0	19	0	1	0	474
16:15	4	129	16	0	1	3	25	0	0	246	0	0	66	0	8	0	498
16:30	12	123	10	0	1	2	35	0	0	261	1	0	52	1	6	0	504
16:45	11	119	16	1	2	1	26	0	1	232	0	0	51	0	5	0	465
Total	59	428	52	1	8	43	119	0	5	1016	1	0	188	1	20	0	1941
17:00	1	85	12	0	0	3	29	0	2	288	0	0	76	1	4	0	501
17:15	4	110	9	0	2	0	39	0	1	271	1	0	53	1	5	0	496
17:30	4	108	10	0	0	3	20	0	3	208	1	0	53	0	8	0	418
17:45	3	113	8	0	4	2	13	0	0	183	0	0	33	1	4	0	364
Total	12	416	39	0	6	8	101	0	6	950	2	0	215	3	21	0	1779
Grand Total	702	4852	978	4	60	94	583	3	165	6028	86	0	916	39	168	1	14679
Apprch %	10.7	74.2	15	0.1	8.1	12.7	78.8	0.4	2.6	96	1.4	0	81.5	3.5	14.9	0.1	
Total %	4.8	33.1	6.7	0	0.4	0.6	4	0	1.1	41.1	0.6	0	6.2	0.3	1.1	0	
Unshifted	682	4699	963	4	56	83	558	3	159	5814	81	0	905	36	162	1	14206
% Unshifted	97.2	96.8	98.5	100	93.3	88.3	95.7	100	96.4	96.4	94.2	0	98.8	92.3	96.4	100	96.8
Bank 1	20	153	15	0	4	11	25	0	6	214	5	0	11	3	6	0	473
% Bank 1	2.8	3.2	1.5	0	6.7	11.7	4.3	0	3.6	3.6	5.8	0	1.2	7.7	3.6	0	3.2

Alliant Engineering Inc Minneapolis, MN 55415

TH-149 at NW Pkwy / Blue Gentian Rd
 Ref.Pt.: 003.761
 Alliant Engineering Inc
 TURN MOVEMENT COUNT

File Name : 15_TH 149 at Northwest Pkwy-Blue Gentian_021810
 Site Code : 00000015
 Start Date : 2/18/2010
 Page No : 3

Start Time	TH-149 / Dodd Rd Southbound					Northwest Parkway Westbound					TH-149 / Dodd Rd Northbound					Blue Gentian Rd Eastbound					Int. Total
	Left	Thru	Right	Peds	App. Total	Left	Thru	Right	Peds	App. Total	Left	Thru	Right	Peds	App. Total	Left	Thru	Right	Peds	App. Total	
Peak Hour Analysis From 06:00 to 09:15 - Peak 1 of 1																					
Peak Hour for Entire Intersection Begins at 07:15																					
07:15	46	248	74	0	368	0	1	6	0	7	6	152	1	0	159	5	1	0	0	6	540
07:30	36	264	45	2	347	1	1	2	3	7	6	177	2	0	185	8	3	7	0	18	557
07:45	50	305	80	0	435	1	2	1	0	4	4	149	1	0	154	7	3	2	0	12	605
08:00	80	235	57	0	372	5	1	4	0	10	5	114	1	0	120	11	3	3	0	17	519
Total Volume	212	1052	256	2	1522	7	5	13	3	28	21	592	5	0	618	31	10	12	0	53	2221
% App. Total	13.9	69.1	16.8	0.1		25	17.9	46.4	10.7		3.4	95.8	0.8	0		58.5	18.9	22.6	0		
PHF	.663	.862	.800	.250	.875	.350	.625	.542	.250	.700	.875	.836	.625	.000	.835	.705	.833	.429	.000	.736	.918

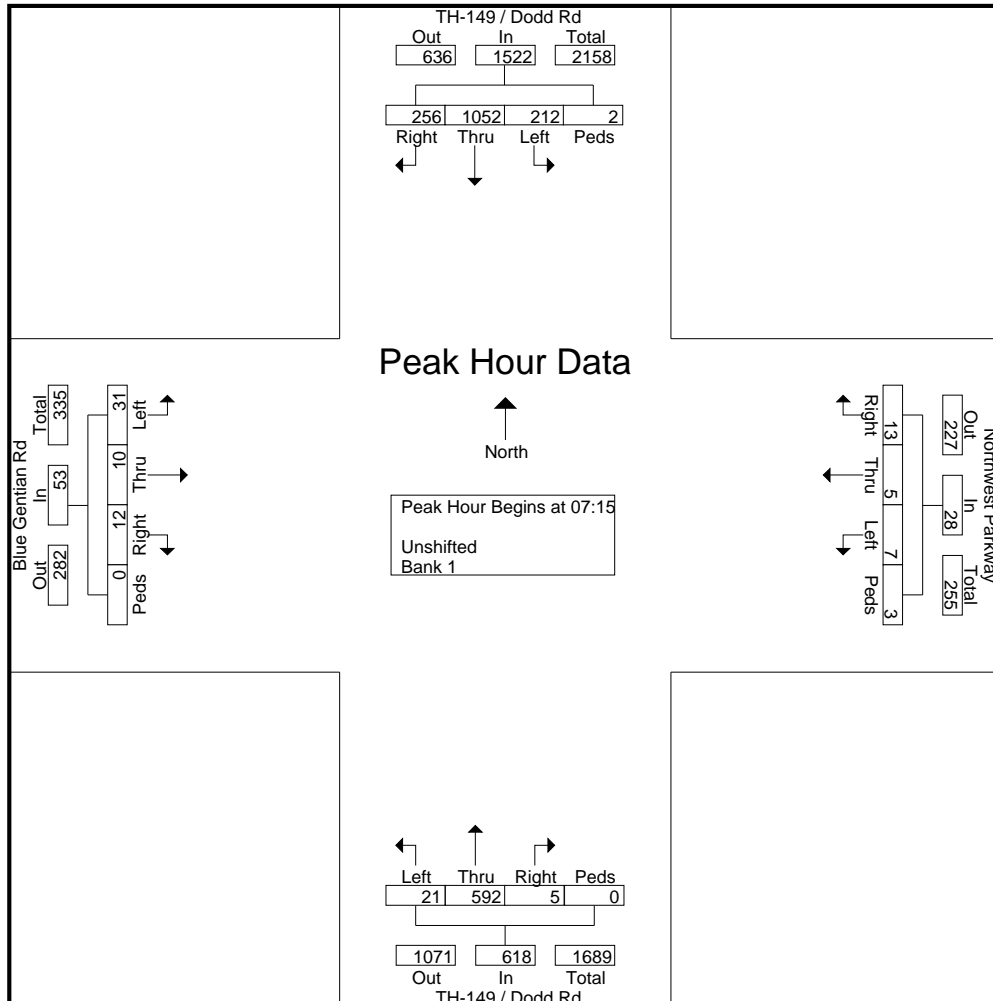

Alliant Engineering Inc Minneapolis, MN 55415

TH-149 at NW Pkwy / Blue Gentian Rd
Ref.Pt.: 003.761
Alliant Engineering Inc
TURN MOVEMENT COUNT

File Name : 15_TH 149 at Northwest Pkwy-Blue Gentian_021810
Site Code : 00000015
Start Date : 2/18/2010
Page No : 4

Start Time	TH-149 / Dodd Rd Southbound					Northwest Parkway Westbound					TH-149 / Dodd Rd Northbound					Blue Gentian Rd Eastbound					Int. Total
	Left	Thru	Right	Peds	App. Total	Left	Thru	Right	Peds	App. Total	Left	Thru	Right	Peds	App. Total	Left	Thru	Right	Peds	App. Total	
Peak Hour Analysis From 15:00 to 17:45 - Peak 1 of 1																					
Peak Hour for Entire Intersection Begins at 16:15																					
16:15	4	129	16	0	149	1	3	25	0	29	0	246	0	0	246	66	0	8	0	74	498
16:30	12	123	10	0	145	1	2	35	0	38	0	261	1	0	262	52	1	6	0	59	504
16:45	11	119	16	1	147	2	1	26	0	29	1	232	0	0	233	51	0	5	0	56	465
17:00	1	85	12	0	98	0	3	29	0	32	2	288	0	0	290	76	1	4	0	81	501
Total Volume	28	456	54	1	539	4	9	115	0	128	3	1027	1	0	1031	245	2	23	0	270	1968
% App. Total	5.2	84.6	10	0.2		3.1	7	89.8	0		0.3	99.6	0.1	0		90.7	0.7	8.5	0		
PHF	.583	.884	.844	.250	.904	.500	.750	.821	.000	.842	.375	.891	.250	.000	.889	.806	.500	.719	.000	.833	.976

