

MN Dept of Transportation

TRAFFIC DATA COLLECTION - Metro

TH-21 at CSAH-2 / 260th St W
 Ref.Pt.: 028.434 (N of New Prague)
 video JI
 TURN MOVEMENT COUNT

File Name : TH-21 at 260th St W CSAH-2 2014
 Site Code :
 Start Date : 8/5/2014
 Page No : 1

Groups Printed- Cars +

Start Time	TH-21 Southbound				CSAH-2 / 260th St W Westbound				TH-21 Northbound				CSAH-2 / 260th St W Eastbound				Int. Total
	Left	Thru	Right	Peds	Left	Thru	Right	Peds	Left	Thru	Right	Peds	Left	Thru	Right	Peds	
06:00	1	5	0	0	4	4	2	0	0	61	6	0	0	2	1	0	86
06:15	2	13	0	0	3	3	3	0	0	68	9	0	0	1	2	0	104
06:30	1	14	0	0	6	1	2	0	2	88	10	0	0	1	1	0	126
06:45	2	18	1	0	5	5	2	0	0	87	4	0	1	1	4	0	130
Total	6	50	1	0	18	13	9	0	2	304	29	0	1	5	8	0	446
07:00	2	22	0	0	7	3	2	0	3	78	7	0	0	3	3	0	130
07:15	1	31	0	0	12	5	8	0	2	93	18	0	0	6	3	0	179
07:30	4	49	0	0	9	9	2	0	2	76	8	0	0	3	6	0	168
07:45	2	37	0	0	15	5	2	0	1	74	17	0	0	4	3	0	160
Total	9	139	0	0	43	22	14	0	8	321	50	0	0	16	15	0	637
08:00	4	42	0	0	9	5	2	0	2	57	4	0	0	2	4	0	131
08:15	2	26	0	0	4	3	0	0	2	44	7	0	0	3	4	0	95
08:30	5	20	0	0	3	2	2	0	2	42	4	0	0	5	2	0	87
08:45	3	19	0	0	12	4	2	0	3	38	6	0	0	7	6	0	100
Total	14	107	0	0	28	14	6	0	9	181	21	0	0	17	16	0	413
***** BREAK *****																	
15:00	6	44	0	0	3	3	3	0	6	33	9	0	2	1	3	0	113
15:15	4	50	1	0	14	2	3	0	2	27	6	0	0	4	8	0	121
15:30	1	40	0	0	9	5	3	0	4	36	8	0	0	4	2	0	112
15:45	3	82	0	0	5	5	1	0	4	29	7	0	0	4	4	0	144
Total	14	216	1	0	31	15	10	0	16	125	30	0	2	13	17	0	490
16:00	3	77	0	0	7	3	2	0	3	40	5	0	0	6	3	0	149
16:15	1	63	0	0	6	5	3	0	2	39	10	0	0	4	2	0	135
16:30	5	83	2	0	11	7	2	0	7	45	9	0	0	6	2	0	179
16:45	6	100	0	0	9	3	2	0	7	32	11	0	0	6	6	0	182
Total	15	323	2	0	33	18	9	0	19	156	35	0	0	22	13	0	645
17:00	2	112	0	0	10	3	6	0	5	40	16	0	0	4	2	0	200
17:15	3	84	0	0	9	6	2	0	4	30	9	0	0	17	9	0	173
17:30	3	83	0	0	10	8	2	0	5	29	4	0	0	3	5	0	152
17:45	8	70	0	0	16	7	3	0	1	32	5	0	0	3	4	0	149
Total	16	349	0	0	45	24	13	0	15	131	34	0	0	27	20	0	674
Grand Total	74	1184	4	0	198	106	61	0	69	1218	199	0	3	100	89	0	3305
Apprch %	5.9	93.8	0.3	0	54.2	29	16.7	0	4.6	82	13.4	0	1.6	52.1	46.4	0	
Total %	2.2	35.8	0.1	0	6	3.2	1.8	0	2.1	36.9	6	0	0.1	3	2.7	0	

MN Dept of Transportation

TRAFFIC DATA COLLECTION - Metro

TH-21 at CSAH-2 / 260th St W
 Ref.Pt.: 028.434 (N of New Prague)
 video JI
 TURN MOVEMENT COUNT

File Name : TH-21 at 260th St W CSAH-2 2014
 Site Code :
 Start Date : 8/5/2014
 Page No : 2

Start Time	TH-21 Southbound					CSAH-2 / 260th St W Westbound					TH-21 Northbound					CSAH-2 / 260th St W Eastbound					Int. Total
	Left	Thru	Right	Peds	App. Total	Left	Thru	Right	Peds	App. Total	Left	Thru	Right	Peds	App. Total	Left	Thru	Right	Peds	App. Total	
Peak Hour Analysis From 06:00 to 11:45 - Peak 1 of 1																					
Peak Hour for Entire Intersection Begins at 07:15																					
07:15	1	31	0	0	32	12	5	8	0	25	2	93	18	0	113	0	6	3	0	9	179
07:30	4	49	0	0	53	9	9	2	0	20	2	76	8	0	86	0	3	6	0	9	168
07:45	2	37	0	0	39	15	5	2	0	22	1	74	17	0	92	0	4	3	0	7	160
08:00	4	42	0	0	46	9	5	2	0	16	2	57	4	0	63	0	2	4	0	6	131
Total Volume	11	159	0	0	170	45	24	14	0	83	7	300	47	0	354	0	15	16	0	31	638
% App. Total	6.5	93.5	0	0		54.2	28.9	16.9	0		2	84.7	13.3	0		0	48.4	51.6	0		
PHF	.688	.811	.000	.000	.802	.750	.667	.438	.000	.830	.875	.806	.653	.000	.783	.000	.625	.667	.000	.861	.891

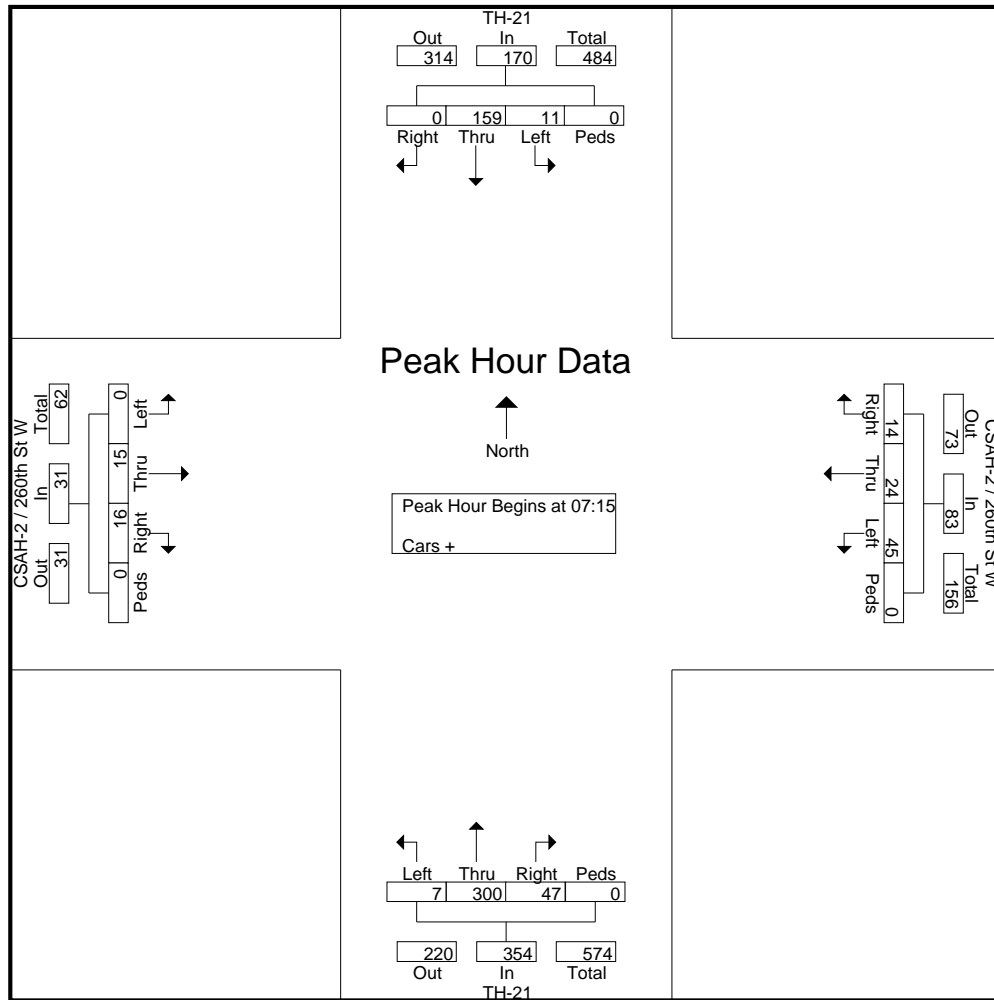

MN Dept of Transportation

TRAFFIC DATA COLLECTION - Metro

TH-21 at CSAH-2 / 260th St W
 Ref.Pt.: 028.434 (N of New Prague)
 video JI
 TURN MOVEMENT COUNT

File Name : TH-21 at 260th St W CSAH-2 2014
 Site Code :
 Start Date : 8/5/2014
 Page No : 3

Start Time	TH-21 Southbound					CSAH-2 / 260th St W Westbound					TH-21 Northbound					CSAH-2 / 260th St W Eastbound					Int. Total
	Left	Thru	Right	Peds	App. Total	Left	Thru	Right	Peds	App. Total	Left	Thru	Right	Peds	App. Total	Left	Thru	Right	Peds	App. Total	
Peak Hour Analysis From 12:00 to 17:45 - Peak 1 of 1																					
Peak Hour for Entire Intersection Begins at 16:30																					
16:30	5	83	2	0	90	11	7	2	0	20	7	45	9	0	61	0	6	2	0	8	179
16:45	6	100	0	0	106	9	3	2	0	14	7	32	11	0	50	0	6	6	0	12	182
17:00	2	112	0	0	114	10	3	6	0	19	5	40	16	0	61	0	4	2	0	6	200
17:15	3	84	0	0	87	9	6	2	0	17	4	30	9	0	43	0	17	9	0	26	173
Total Volume	16	379	2	0	397	39	19	12	0	70	23	147	45	0	215	0	33	19	0	52	734
% App. Total	4	95.5	0.5	0		55.7	27.1	17.1	0		10.7	68.4	20.9	0		0	63.5	36.5	0		
PHF	.667	.846	.250	.000	.871	.886	.679	.500	.000	.875	.821	.817	.703	.000	.881	.000	.485	.528	.000	.500	.918

