

# MN Dept of Transportation

TRAFFIC DATA COLLECTION - Metro

TH-282 at CSAH-17 (west of TH-13)  
 Ref.Pt.: 007.590  
 video MR  
 TURN MOVEMENT COUNT

File Name : TH-282 at CSAH-17 Marschall Rd 2014  
 Site Code :  
 Start Date : 8/13/2014  
 Page No : 1

Groups Printed- Cars +

Start Time	CSAH-17 / Marschall Rd Southbound				TH-282 Westbound				CSAH-17 / Marschall Rd Northbound				TH-282 Eastbound				Int. Total
	Left	Thru	Right	Peds	Left	Thru	Right	Peds	Left	Thru	Right	Peds	Left	Thru	Right	Peds	
06:00	0	5	4	0	0	11	6	0	8	46	0	0	8	31	1	0	120
06:15	0	4	3	0	0	22	7	0	1	52	0	0	11	29	1	0	130
06:30	2	11	3	0	0	16	7	0	2	83	0	0	15	38	3	0	180
06:45	5	6	5	0	0	38	11	0	3	79	0	0	13	51	3	0	214
Total	7	26	15	0	0	87	31	0	14	260	0	0	47	149	8	0	644
07:00	4	3	5	0	0	29	10	0	3	50	0	0	8	38	3	0	153
07:15	6	26	6	0	0	26	13	0	5	74	0	0	15	49	3	0	223
07:30	5	19	11	0	0	36	18	0	2	82	0	0	13	46	3	0	235
07:45	5	19	7	0	0	33	8	0	6	69	0	0	18	43	4	0	212
Total	20	67	29	0	0	124	49	0	16	275	0	0	54	176	13	0	823
08:00	4	17	6	0	0	32	14	0	4	56	0	0	6	35	2	0	176
08:15	4	13	8	0	0	22	12	0	6	53	0	0	21	34	1	0	174
08:30	2	13	5	0	0	37	4	0	4	53	1	0	11	34	3	0	167
08:45	2	14	8	0	1	28	7	0	3	38	0	0	13	26	3	0	143
Total	12	57	27	0	1	119	37	0	17	200	1	0	51	129	9	0	660
*****BREAK*****																	
15:00	5	52	13	0	0	38	6	0	1	20	0	0	11	24	4	0	174
15:15	6	56	16	0	0	41	5	0	4	17	0	0	7	28	4	0	184
15:30	7	48	10	0	0	39	5	0	4	14	0	0	8	26	7	0	168
15:45	6	66	13	0	0	45	2	0	4	26	0	0	12	36	4	0	214
Total	24	222	52	0	0	163	18	0	13	77	0	0	38	114	19	0	740
16:00	7	48	21	0	0	39	7	0	3	20	0	0	16	30	8	0	199
16:15	10	64	20	0	0	49	5	0	2	27	0	0	8	43	6	0	234
16:30	7	99	18	0	0	44	4	0	3	20	0	0	9	40	4	0	248
16:45	13	77	25	0	0	56	10	0	2	34	0	0	12	46	6	0	281
Total	37	288	84	0	0	188	26	0	10	101	0	0	45	159	24	0	962
17:00	8	75	23	0	0	50	5	0	11	23	0	0	16	42	8	0	261
17:15	8	82	29	0	0	39	8	0	1	22	0	0	13	47	8	0	257
17:30	8	70	25	0	0	57	7	0	5	33	0	0	6	54	3	0	268
17:45	11	77	21	0	0	47	5	0	2	29	0	0	13	34	4	0	243
Total	35	304	98	0	0	193	25	0	19	107	0	0	48	177	23	0	1029
*****BREAK*****																	
Grand Total	135	964	305	0	1	874	186	0	89	1020	1	0	283	904	96	0	4858
Apprch %	9.6	68.7	21.7	0	0.1	82.4	17.5	0	8	91.9	0.1	0	22.1	70.5	7.5	0	
Total %	2.8	19.8	6.3	0	0	18	3.8	0	1.8	21	0	0	5.8	18.6	2	0	

# MN Dept of Transportation

TRAFFIC DATA COLLECTION - Metro

TH-282 at CSAH-17 (west of TH-13)  
 Ref.Pt.: 007.590  
 video MR  
 TURN MOVEMENT COUNT

File Name : TH-282 at CSAH-17 Marschall Rd 2014  
 Site Code :  
 Start Date : 8/13/2014  
 Page No : 2

Start Time	CSAH-17 / Marschall Rd Southbound					TH-282 Westbound					CSAH-17 / Marschall Rd Northbound					TH-282 Eastbound					Int. Total
	Left	Thru	Right	Peds	App. Total	Left	Thru	Right	Peds	App. Total	Left	Thru	Right	Peds	App. Total	Left	Thru	Right	Peds	App. Total	
Peak Hour Analysis From 06:00 to 08:45 - Peak 1 of 1																					
Peak Hour for Entire Intersection Begins at 07:15																					
07:15	6	26	6	0	38	0	26	13	0	39	5	74	0	0	79	15	49	3	0	67	223
07:30	5	19	11	0	35	0	36	18	0	54	2	82	0	0	84	13	46	3	0	62	235
07:45	5	19	7	0	31	0	33	8	0	41	6	69	0	0	75	18	43	4	0	65	212
08:00	4	17	6	0	27	0	32	14	0	46	4	56	0	0	60	6	35	2	0	43	176
Total Volume	20	81	30	0	131	0	127	53	0	180	17	281	0	0	298	52	173	12	0	237	846
% App. Total	15.3	61.8	22.9	0		0	70.6	29.4	0		5.7	94.3	0	0		21.9	73	5.1	0		
PHF	.833	.779	.682	.000	.862	.000	.882	.736	.000	.833	.708	.857	.000	.000	.887	.722	.883	.750	.000	.884	.900

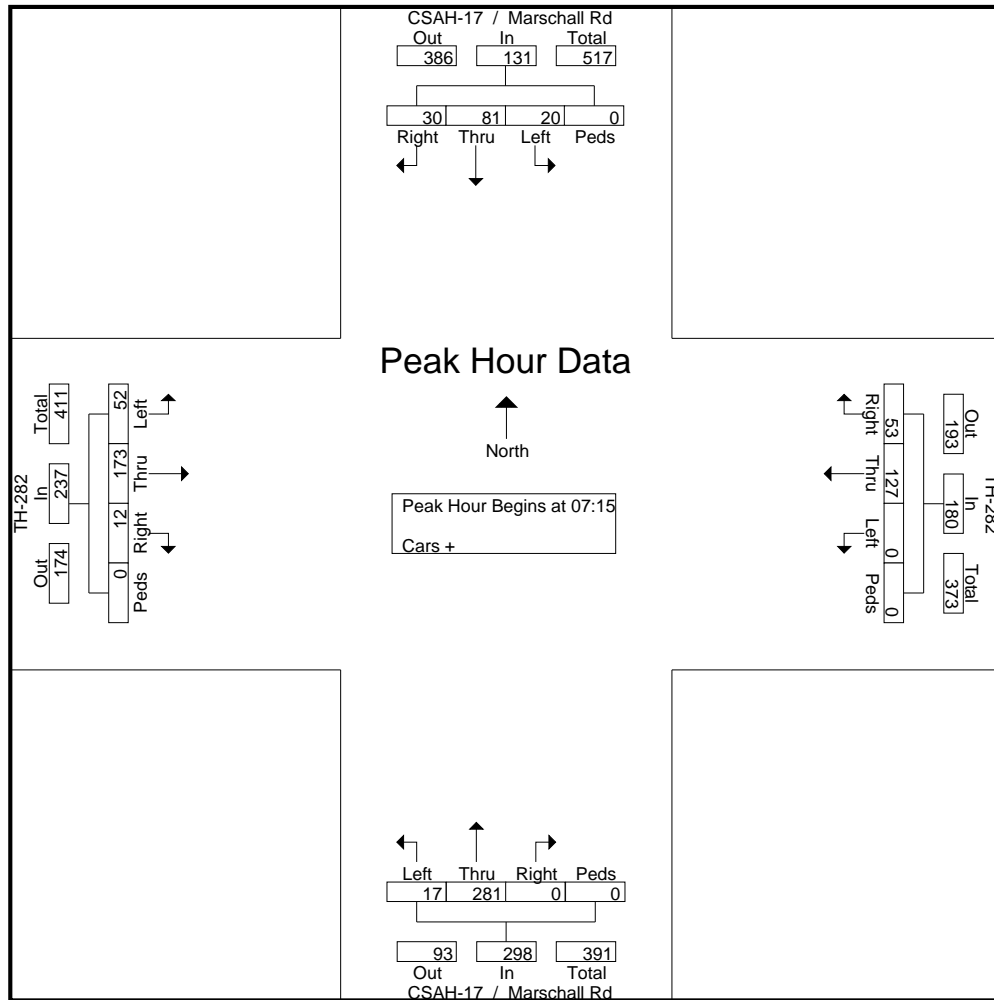

# MN Dept of Transportation

TRAFFIC DATA COLLECTION - Metro

TH-282 at CSAH-17 (west of TH-13)  
 Ref.Pt.: 007.590  
 video MR  
 TURN MOVEMENT COUNT

File Name : TH-282 at CSAH-17 Marschall Rd 2014  
 Site Code :  
 Start Date : 8/13/2014  
 Page No : 3

Start Time	CSAH-17 / Marschall Rd Southbound					TH-282 Westbound					CSAH-17 / Marschall Rd Northbound					TH-282 Eastbound					Int. Total
	Left	Thru	Right	Peds	App. Total	Left	Thru	Right	Peds	App. Total	Left	Thru	Right	Peds	App. Total	Left	Thru	Right	Peds	App. Total	
Peak Hour Analysis From 15:00 to 17:45 - Peak 1 of 1																					
Peak Hour for Entire Intersection Begins at 16:45																					
16:45	13	77	25	0	115	0	56	10	0	66	2	34	0	0	36	12	46	6	0	64	281
17:00	8	75	23	0	106	0	50	5	0	55	11	23	0	0	34	16	42	8	0	66	261
17:15	8	82	29	0	119	0	39	8	0	47	1	22	0	0	23	13	47	8	0	68	257
17:30	8	70	25	0	103	0	57	7	0	64	5	33	0	0	38	6	54	3	0	63	268
Total Volume	37	304	102	0	443	0	202	30	0	232	19	112	0	0	131	47	189	25	0	261	1067
% App. Total	8.4	68.6	23	0		0	87.1	12.9	0		14.5	85.5	0	0		18	72.4	9.6	0		
PHF	.712	.927	.879	.000	.931	.000	.886	.750	.000	.879	.432	.824	.000	.000	.862	.734	.875	.781	.000	.960	.949

