

MN Dept of Transportation

TRAFFIC DATA COLLECTION - Metro

TH-13 at TH-282
 Ref.Pt.: 080.942
 video MR
 TURN MOVEMENT COUNT

File Name : TH-13 at TH-282 2014
 Site Code :
 Start Date : 8/13/2014
 Page No : 1

Groups Printed- Cars +

Start Time	TH-13 Southbound				TH-13 Northbound				TH-282 Eastbound				Int. Total
	Left	Thru	Right	Peds	Left	Thru	Right	Peds	Left	Thru	Right	Peds	
06:00	0	3	17	0	0	19	0	0	34	0	0	0	73
06:15	0	6	33	0	0	24	0	0	24	0	0	0	87
06:30	0	7	22	0	0	28	0	0	41	0	0	0	98
06:45	0	9	53	0	0	23	0	0	60	0	0	0	145
Total	0	25	125	0	0	94	0	0	159	0	0	0	403
07:00	0	2	35	0	0	27	0	0	40	0	0	0	104
07:15	0	10	42	0	0	24	0	0	52	0	0	0	128
07:30	0	8	54	0	0	20	0	0	51	0	0	0	133
07:45	0	11	36	0	0	30	0	0	47	0	0	0	124
Total	0	31	167	0	0	101	0	0	190	0	0	0	489
08:00	0	18	42	0	0	26	0	0	40	0	1	0	127
08:15	0	12	36	0	0	36	0	0	42	0	1	0	127
08:30	0	10	39	0	0	16	0	0	30	0	1	0	96
08:45	0	15	38	0	0	17	0	0	26	0	0	0	96
Total	0	55	155	0	0	95	0	0	138	0	3	0	446
*****BREAK*****													
15:00	0	25	44	0	0	12	0	0	28	0	0	0	109
15:15	0	31	46	0	0	17	0	0	34	0	0	0	128
15:30	0	31	41	0	0	13	0	0	31	0	0	0	116
15:45	0	30	51	0	0	18	0	0	38	0	0	0	137
Total	0	117	182	0	0	60	0	0	131	0	0	0	490
16:00	0	34	45	0	0	15	0	0	42	0	0	0	136
16:15	0	34	57	0	0	23	0	0	53	0	0	0	167
16:30	0	26	50	0	0	26	0	0	43	0	0	0	145
16:45	0	41	65	0	0	24	0	0	59	0	0	0	189
Total	0	135	217	0	0	88	0	0	197	0	0	0	637
17:00	0	30	49	0	0	16	0	0	53	0	0	0	148
17:15	0	37	51	0	0	27	0	0	56	0	0	0	171
17:30	0	27	60	0	0	31	0	0	64	0	0	0	182
17:45	0	18	50	0	0	19	0	0	48	0	0	0	135
Total	0	112	210	0	0	93	0	0	221	0	0	0	636
Grand Total	0	475	1056	0	0	531	0	0	1036	0	3	0	3101
Apprch %	0	31	69	0	0	100	0	0	99.7	0	0.3	0	
Total %	0	15.3	34.1	0	0	17.1	0	0	33.4	0	0.1	0	

MN Dept of Transportation

TRAFFIC DATA COLLECTION - Metro

TH-13 at TH-282
 Ref.Pt.: 080.942
 video MR
 TURN MOVEMENT COUNT

File Name : TH-13 at TH-282 2014
 Site Code :
 Start Date : 8/13/2014
 Page No : 2

Start Time	TH-13 Southbound					TH-13 Northbound					TH-282 Eastbound					Int. Total
	Left	Thru	Right	Peds	App. Total	Left	Thru	Right	Peds	App. Total	Left	Thru	Right	Peds	App. Total	
Peak Hour Analysis From 06:00 to 08:45 - Peak 1 of 1																
Peak Hour for Entire Intersection Begins at 07:15																
07:15	0	10	42	0	52	0	24	0	0	24	52	0	0	0	52	128
07:30	0	8	54	0	62	0	20	0	0	20	51	0	0	0	51	133
07:45	0	11	36	0	47	0	30	0	0	30	47	0	0	0	47	124
08:00	0	18	42	0	60	0	26	0	0	26	40	0	1	0	41	127
Total Volume	0	47	174	0	221	0	100	0	0	100	190	0	1	0	191	512
% App. Total	0	21.3	78.7	0		0	100	0	0		99.5	0	0.5	0		
PHF	.000	.653	.806	.000	.891	.000	.833	.000	.000	.833	.913	.000	.250	.000	.918	.962

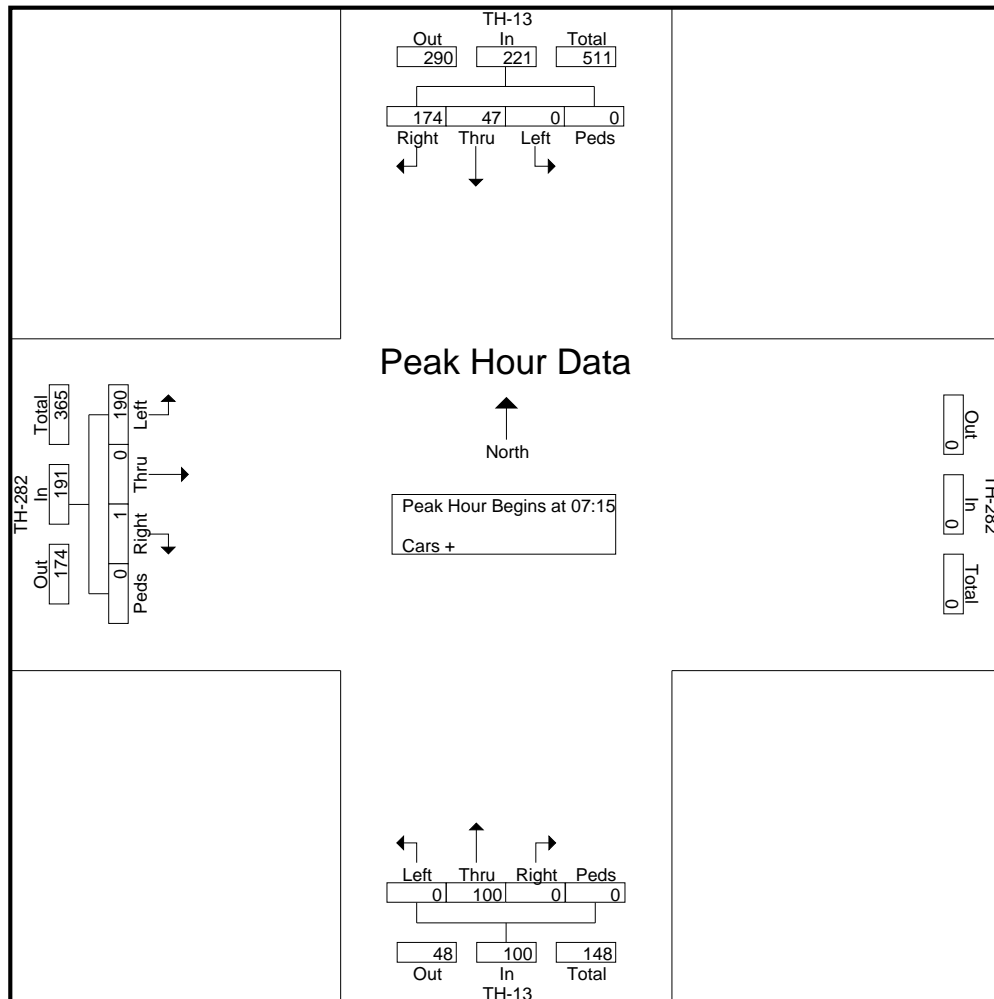

MN Dept of Transportation

TRAFFIC DATA COLLECTION - Metro

TH-13 at TH-282
 Ref.Pt.: 080.942
 video MR
 TURN MOVEMENT COUNT

File Name : TH-13 at TH-282 2014
 Site Code :
 Start Date : 8/13/2014
 Page No : 3

Start Time	TH-13 Southbound					TH-13 Northbound					TH-282 Eastbound					Int. Total
	Left	Thru	Right	Peds	App. Total	Left	Thru	Right	Peds	App. Total	Left	Thru	Right	Peds	App. Total	
Peak Hour Analysis From 15:00 to 17:45 - Peak 1 of 1																
Peak Hour for Entire Intersection Begins at 16:45																
16:45	0	41	65	0	106	0	24	0	0	24	59	0	0	0	59	189
17:00	0	30	49	0	79	0	16	0	0	16	53	0	0	0	53	148
17:15	0	37	51	0	88	0	27	0	0	27	56	0	0	0	56	171
17:30	0	27	60	0	87	0	31	0	0	31	64	0	0	0	64	182
Total Volume	0	135	225	0	360	0	98	0	0	98	232	0	0	0	232	690
% App. Total	0	37.5	62.5	0		0	100	0	0		100	0	0	0		
PHF	.000	.823	.865	.000	.849	.000	.790	.000	.000	.790	.906	.000	.000	.000	.906	.913

