

Associated Consulting Services (ACS)
 Roseville, MN 55113
 -- TRAFFIC DATA --

MN-3 at CSAH-86_2022

City: Dakota Cnty

Data Prepared By: ACS

TURNING MOVEMENT COUNT

File Name : MN-3 at CSAH-86_2022

Site Code :

Start Date : 5/3/2022

Page No : 1

Groups Printed- Cars - Trucks

Start Time	MN-3 Southbound				CSAH-86 Westbound				MN-3 Northbound				CSAH-86 Eastbound				Int. Total
	Left	Thru	Right	Peds	Left	Thru	Right	Peds	Left	Thru	Right	Peds	Left	Thru	Right	Peds	
06:00	2	15	4	0	2	15	3	0	3	28	0	0	4	9	0	0	85
06:15	2	20	2	0	0	19	5	0	7	46	0	0	8	15	1	0	125
06:30	3	34	4	0	0	15	5	0	10	56	1	0	11	21	3	0	163
06:45	0	43	5	0	3	10	6	0	5	48	1	0	5	13	8	0	147
Total	7	112	15	0	5	59	19	0	25	178	2	0	28	58	12	0	520
07:00	2	42	2	0	2	14	2	0	4	43	0	0	3	21	7	0	142
07:15	5	49	2	0	2	18	6	0	12	50	0	0	4	16	10	0	174
07:30	6	53	6	0	2	13	6	0	8	40	1	0	9	18	11	0	173
07:45	3	36	6	0	0	21	4	0	30	46	1	0	3	17	5	0	172
Total	16	180	16	0	6	66	18	0	54	179	2	0	19	72	33	0	661
08:00	4	24	10	0	1	25	4	0	37	33	1	0	6	18	33	0	196
08:15	2	26	8	0	0	13	4	0	6	26	0	0	6	17	23	0	131
08:30	5	37	3	0	1	4	2	0	5	28	2	0	5	16	6	0	114
08:45	1	16	1	0	2	11	2	0	3	17	1	0	0	14	5	0	73
Total	12	103	22	0	4	53	12	0	51	104	4	0	17	65	67	0	514
09:00	0	23	3	0	1	13	5	0	2	19	1	0	1	7	5	0	80
09:15	4	12	2	0	0	12	1	0	6	19	1	0	4	10	6	0	77
09:30	0	22	2	0	1	15	1	0	9	21	1	0	6	9	2	0	89
09:45	4	32	3	0	0	12	2	0	5	21	0	0	3	8	4	0	94
Total	8	89	10	0	2	52	9	0	22	80	3	0	14	34	17	0	340
10:00	1	22	1	0	1	14	1	0	3	25	0	0	4	17	1	0	90
10:15	2	23	3	0	0	12	2	0	7	26	4	0	4	10	5	0	98
10:30	0	22	2	0	5	15	1	0	3	18	0	0	2	11	8	0	87
10:45	1	13	2	0	0	9	1	0	8	13	4	0	3	12	8	0	74
Total	4	80	8	0	6	50	5	0	21	82	8	0	13	50	22	0	349
11:00	3	24	1	0	2	5	1	0	5	20	1	0	3	13	6	0	84
11:15	6	19	1	0	0	5	2	0	7	17	2	0	7	11	4	0	81
11:30	4	23	6	0	0	13	1	0	5	20	2	0	2	18	8	0	102
11:45	3	33	3	0	0	11	3	0	5	25	1	0	5	15	7	0	111
Total	16	99	11	0	2	34	7	0	22	82	6	0	17	57	25	0	378
12:00	1	18	5	0	2	15	2	0	6	20	2	0	2	11	7	0	91
12:15	0	31	3	0	1	12	0	0	6	22	3	0	5	16	4	0	103
12:30	1	19	5	0	1	20	4	0	3	24	1	0	1	11	13	0	103
12:45	4	26	2	0	1	11	0	0	6	25	1	0	1	10	7	0	94
Total	6	94	15	0	5	58	6	0	21	91	7	0	9	48	31	0	391
13:00	0	19	5	0	0	14	5	0	6	26	1	0	3	17	8	0	104
13:15	1	23	8	0	1	14	2	0	6	35	0	0	6	14	6	0	116
13:30	0	28	8	0	0	13	2	0	4	33	3	0	2	18	5	0	116
13:45	2	30	3	0	2	11	4	0	5	22	1	0	8	9	4	0	101
Total	3	100	24	0	3	52	13	0	21	116	5	0	19	58	23	0	437
14:00	3	32	7	0	0	10	6	0	13	31	2	0	3	17	2	0	126
14:15	3	44	7	0	0	15	5	0	16	28	3	0	1	20	11	0	153
14:30	5	38	7	0	2	17	2	0	19	32	2	0	13	21	39	0	197
14:45	7	26	6	0	1	19	4	0	5	32	1	0	4	18	7	0	130
Total	18	140	27	0	3	61	17	0	53	123	8	0	21	76	59	0	606

Associated Consulting Services (ACS)
 Roseville, MN 55113
 -- TRAFFIC DATA --

MN-3 at CSAH-86_2022

City: Dakota Cnty

Data Prepared By: ACS

TURNING MOVEMENT COUNT

File Name : MN-3 at CSAH-86_2022

Site Code :

Start Date : 5/3/2022

Page No : 2

Groups Printed- Cars - Trucks

Start Time	MN-3 Southbound				CSAH-86 Westbound				MN-3 Northbound				CSAH-86 Eastbound				Int. Total
	Left	Thru	Right	Peds	Left	Thru	Right	Peds	Left	Thru	Right	Peds	Left	Thru	Right	Peds	
15:00	3	33	5	0	1	25	2	0	8	30	1	0	5	19	6	0	138
15:15	4	38	9	0	2	12	1	0	6	44	4	0	6	23	6	0	155
15:30	6	50	5	0	0	17	4	0	10	47	2	0	5	16	12	0	174
15:45	11	46	6	0	0	27	7	0	8	34	2	0	4	19	8	0	172
Total	24	167	25	0	3	81	14	0	32	155	9	0	20	77	32	0	639
16:00	8	44	9	0	1	28	3	0	6	45	3	0	5	13	7	0	172
16:15	6	39	6	0	1	19	4	0	12	36	0	0	10	27	8	0	168
16:30	6	37	11	0	1	12	6	0	5	57	4	0	7	21	6	0	173
16:45	2	50	7	0	1	25	4	0	9	48	4	0	7	19	17	0	193
Total	22	170	33	0	4	84	17	0	32	186	11	0	29	80	38	0	706
17:00	5	65	18	0	0	19	4	0	12	47	3	0	6	21	8	0	208
17:15	3	56	2	0	1	19	6	0	13	53	4	0	4	26	7	0	194
17:30	4	41	7	0	1	19	4	0	6	34	1	0	9	19	10	0	155
17:45	2	28	6	0	0	16	3	0	7	40	3	0	7	14	5	0	131
Total	14	190	33	0	2	73	17	0	38	174	11	0	26	80	30	0	688
Grand Total	150	1524	239	0	45	723	154	0	392	1550	76	0	232	755	389	0	6229
Apprch %	7.8	79.7	12.5	0	4.9	78.4	16.7	0	19.4	76.8	3.8	0	16.9	54.9	28.3	0	
Total %	2.4	24.5	3.8	0	0.7	11.6	2.5	0	6.3	24.9	1.2	0	3.7	12.1	6.2	0	
Cars	128	1435	212	0	41	607	127	0	356	1450	67	0	204	636	349	0	5612
% Cars	85.3	94.2	88.7	0	91.1	84	82.5	0	90.8	93.5	88.2	0	87.9	84.2	89.7	0	90.1
Trucks	22	89	27	0	4	116	27	0	36	100	9	0	28	119	40	0	617
% Trucks	14.7	5.8	11.3	0	8.9	16	17.5	0	9.2	6.5	11.8	0	12.1	15.8	10.3	0	9.9

Associated Consulting Services (ACS)
 Roseville, MN 55113
 -- TRAFFIC DATA --

MN-3 at CSAH-86_2022

City: Dakota Cnty

Data Prepared By: ACS

TURNING MOVEMENT COUNT

File Name : MN-3 at CSAH-86_2022

Site Code :

Start Date : 5/3/2022

Page No : 3

Start Time	MN-3 Southbound					CSAH-86 Westbound					MN-3 Northbound					CSAH-86 Eastbound					Int. Total
	Left	Thru	Right	Peds	App. Total	Left	Thru	Right	Peds	App. Total	Left	Thru	Right	Peds	App. Total	Left	Thru	Right	Peds	App. Total	
Peak Hour Analysis From 06:00 to 11:45 - Peak 1 of 1																					
Peak Hour for Entire Intersection Begins at 07:15																					
07:15	5	49	2	0	56	2	18	6	0	26	12	50	0	0	62	4	16	10	0	30	174
07:30	6	53	6	0	65	2	13	6	0	21	8	40	1	0	49	9	18	11	0	38	173
07:45	3	36	6	0	45	0	21	4	0	25	30	46	1	0	77	3	17	5	0	25	172
08:00	4	24	10	0	38	1	25	4	0	30	37	33	1	0	71	6	18	33	0	57	196
Total Volume	18	162	24	0	204	5	77	20	0	102	87	169	3	0	259	22	69	59	0	150	715
% App. Total	8.8	79.4	11.8	0		4.9	75.5	19.6	0		33.6	65.3	1.2	0		14.7	46	39.3	0		
PHF	.750	.764	.600	.000	.785	.625	.770	.833	.000	.850	.588	.845	.750	.000	.841	.611	.958	.447	.000	.658	.912

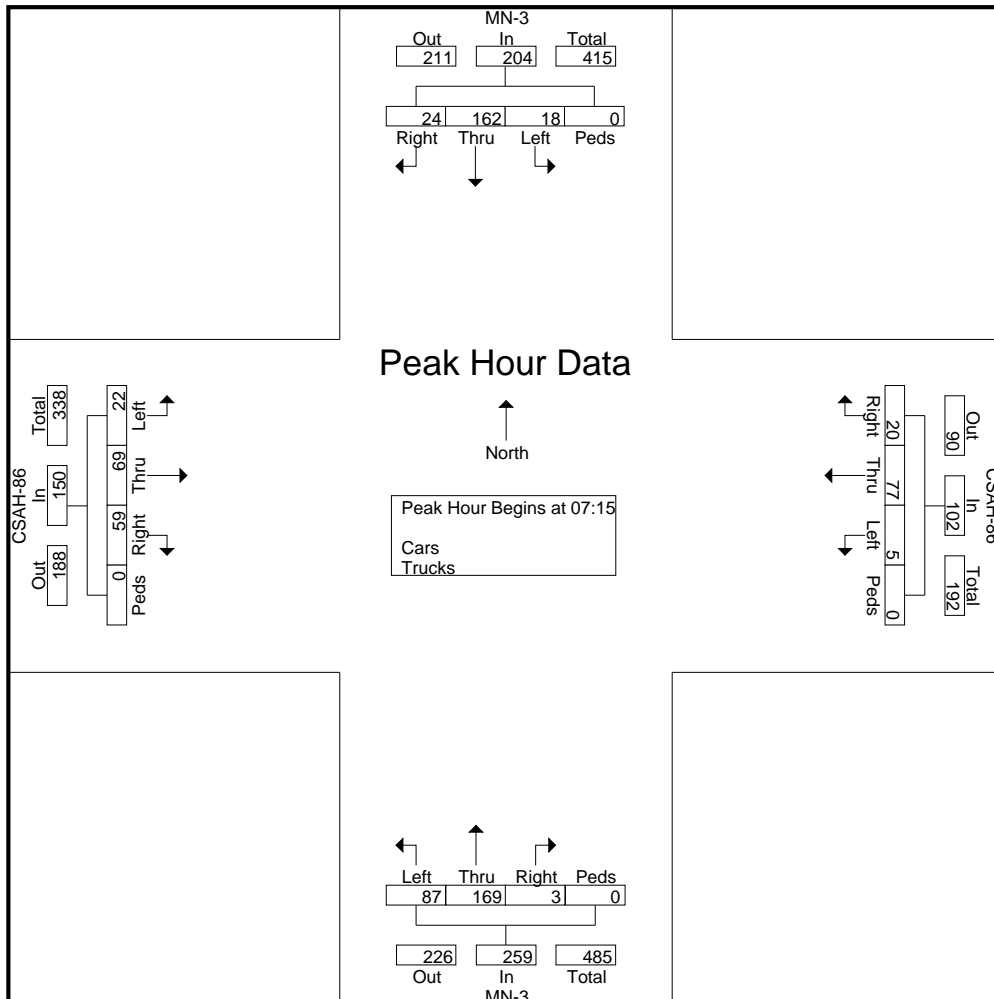

Associated Consulting Services (ACS)
 Roseville, MN 55113
 -- TRAFFIC DATA --

MN-3 at CSAH-86_2022

City: Dakota Cnty

Data Prepared By: ACS

TURNING MOVEMENT COUNT

File Name : MN-3 at CSAH-86_2022

Site Code :

Start Date : 5/3/2022

Page No : 4

Start Time	MN-3 Southbound					CSAH-86 Westbound					MN-3 Northbound					CSAH-86 Eastbound					Int. Total
	Left	Thru	Right	Peds	App. Total	Left	Thru	Right	Peds	App. Total	Left	Thru	Right	Peds	App. Total	Left	Thru	Right	Peds	App. Total	
Peak Hour Analysis From 12:00 to 17:45 - Peak 1 of 1																					
Peak Hour for Entire Intersection Begins at 16:30																					
16:30	6	37	11	0	54	1	12	6	0	19	5	57	4	0	66	7	21	6	0	34	173
16:45	2	50	7	0	59	1	25	4	0	30	9	48	4	0	61	7	19	17	0	43	193
17:00	5	65	18	0	88	0	19	4	0	23	12	47	3	0	62	6	21	8	0	35	208
17:15	3	56	2	0	61	1	19	6	0	26	13	53	4	0	70	4	26	7	0	37	194
Total Volume	16	208	38	0	262	3	75	20	0	98	39	205	15	0	259	24	87	38	0	149	768
% App. Total	6.1	79.4	14.5	0		3.1	76.5	20.4	0		15.1	79.2	5.8	0		16.1	58.4	25.5	0		
PHF	.667	.800	.528	.000	.744	.750	.750	.833	.000	.817	.750	.899	.938	.000	.925	.857	.837	.559	.000	.866	.923

