

Start Time	CR 50/Elm St EB				9th St WB				TH 3 NB				TH 3 SB				15 min Veh. Total	15 min Ped Total
	L	T	R	Ped	L	T	R	Ped	L	T	R	Ped	L	T	R	Ped		
000	6	1	4	-	-	-	-	-	4	5	-	-	-	3	2	-	25	-
015	4	1	3	-	-	1	-	-	-	-	-	-	-	4	-	-	13	-
030	4	1	6	-	-	1	-	-	3	2	-	-	-	3	1	-	21	-
045	6	-	5	-	-	-	-	-	3	3	-	-	1	-	3	-	21	-
100	3	1	4	-	-	-	-	-	4	-	-	-	-	3	2	-	17	-
115	2	-	2	-	-	1	-	-	1	2	-	-	-	2	-	-	10	-
130	1	2	-	-	-	-	-	-	-	1	-	-	-	5	-	-	9	-
145	2	-	2	-	-	-	-	-	1	-	-	-	-	-	2	-	7	-
200	7	2	2	-	-	-	-	-	-	1	-	-	-	1	-	-	13	-
215	2	1	1	-	-	1	-	-	2	1	-	-	-	1	2	-	11	-
230	2	-	2	-	-	-	-	-	-	2	-	-	-	3	1	-	10	-
245	-	1	2	-	-	-	-	-	4	3	-	-	-	2	1	-	13	-
300	5	-	-	-	-	-	-	-	1	3	-	-	-	2	4	-	15	-
315	1	-	-	-	-	-	-	-	3	-	-	-	-	3	1	-	8	-
330	-	-	3	-	-	-	-	-	3	4	-	-	-	1	3	-	14	-
345	3	-	1	-	-	-	-	-	4	3	-	-	-	1	5	-	17	-
400	3	2	1	-	-	-	-	-	5	2	1	-	-	1	5	-	20	-
415	4	-	5	-	1	2	-	-	4	5	-	-	-	5	6	-	32	-
430	2	1	3	-	-	2	1	-	15	7	-	-	-	3	7	-	41	-
445	5	1	4	-	-	2	3	-	13	13	-	-	1	5	16	-	63	-
500	6	-	5	-	-	9	-	-	12	14	-	-	-	8	8	-	62	-
515	4	-	5	-	-	5	2	-	18	24	1	-	2	10	20	-	91	-
530	8	-	10	-	-	10	4	-	30	25	-	-	1	17	21	-	126	-
545	15	2	12	-	-	2	3	-	22	30	-	-	2	8	42	-	138	-
600	25	5	8	-	-	14	3	-	24	38	-	-	1	17	46	-	181	-
615	24	1	8	-	-	14	6	-	20	36	-	-	-	28	46	-	183	-
630	30	4	15	-	1	19	9	-	30	58	1	-	4	35	52	-	258	-
645	41	4	13	-	-	13	7	-	40	74	1	-	1	42	52	-	288	-
700	41	4	12	-	-	12	8	2	25	76	3	-	5	43	59	1	288	3
715	41	9	22	-	-	25	10	-	29	63	-	-	1	49	77	-	326	-
730	51	1	13	-	1	14	6	-	46	68	-	-	1	48	56	-	305	-
745	33	6	19	-	-	22	7	-	45	50	2	-	1	54	61	-	300	-
800	39	8	10	-	-	15	3	-	31	55	1	-	1	32	72	-	267	-
815	45	4	21	-	-	12	8	-	36	50	-	-	1	29	60	-	266	-
830	32	6	19	-	2	13	11	-	25	48	1	-	1	43	53	-	254	-
845	37	6	22	-	-	5	3	-	33	40	1	-	2	36	43	-	228	-
900	41	4	14	-	1	10	3	-	15	36	1	-	1	25	28	-	179	-
915	25	4	21	-	1	5	5	-	18	36	-	-	3	34	36	-	188	-
930	33	6	19	-	-	6	3	-	16	27	1	-	2	31	27	-	171	-
945	41	4	24	-	-	3	3	-	30	27	-	-	-	46	48	-	226	-
1000	24	4	26	-	-	6	-	-	23	37	1	-	1	22	42	-	186	-
1015	18	3	24	-	-	5	1	-	22	39	1	-	6	31	27	-	177	-
1030	29	4	22	-	-	1	2	-	23	29	-	-	1	35	25	-	171	-
1045	22	7	19	-	-	8	3	-	19	42	1	-	1	36	34	-	192	-
1100	35	6	16	-	-	4	6	-	30	33	1	-	4	30	26	-	191	-
1115	36	6	17	-	-	12	3	-	24	29	-	-	3	26	24	-	180	-
1130	39	9	34	-	-	10	6	-	25	46	1	-	1	51	32	-	254	-
1145	47	3	17	-	1	9	6	-	33	36	1	-	1	37	38	-	229	-

Start Time	CR 50/Elm St EB				9th St WB				TH 3 NB				TH 3 SB				15 min Veh. Total	15 min Ped Total
	L	T	R	Ped	L	T	R	Ped	L	T	R	Ped	L	T	R	Ped		
1200	35	3	18	-	1	6	4	-	31	39	-	-	2	47	38	-	224	-
1215	47	5	21	-	-	6	4	-	34	41	-	-	3	46	33	-	240	-
1230	39	4	23	-	1	5	5	-	30	37	-	-	1	34	39	-	218	-
1245	29	11	20	1	1	7	2	-	18	35	-	-	1	44	45	-	213	1
1300	49	4	28	-	1	5	2	-	28	35	1	-	3	32	41	-	229	-
1315	27	5	35	-	-	6	2	-	25	25	1	-	2	43	42	-	213	-
1330	46	3	26	-	-	3	3	-	23	31	1	-	5	33	28	-	202	-
1345	28	10	25	-	-	7	5	-	27	28	-	-	7	37	45	-	219	-
1400	40	8	26	-	2	7	3	-	10	43	4	-	3	53	41	-	240	-
1415	52	6	29	-	1	7	5	1	35	41	2	1	7	46	56	-	287	2
1430	73	4	30	-	-	10	4	2	32	38	-	-	3	45	50	1	289	3
1445	39	7	20	-	1	6	5	-	31	44	-	-	2	44	38	-	237	-
1500	79	6	24	-	-	8	4	-	36	45	-	-	6	67	46	-	321	-
1515	67	17	37	1	2	8	6	-	19	36	-	-	2	76	52	2	322	3
1530	78	12	41	-	-	4	5	-	42	68	1	-	7	65	44	1	367	1
1545	72	18	43	2	2	10	10	1	38	70	-	1	7	75	35	-	380	4
1600	66	10	29	-	2	11	3	-	40	69	-	-	1	82	66	-	379	-
1615	91	14	38	-	-	10	3	-	38	71	1	-	1	75	52	-	394	-
1630	79	14	29	-	2	12	3	-	35	66	1	-	8	95	49	-	393	-
1645	70	13	58	5	-	16	5	-	31	62	-	4	4	75	82	-	416	9
1700	72	20	51	1	2	11	9	-	34	82	1	-	7	94	47	-	430	1
1715	84	14	56	4	-	10	5	-	37	80	-	-	9	67	58	1	420	5
1730	68	10	43	-	1	7	8	-	39	59	1	1	5	84	59	-	384	1
1745	76	14	36	-	-	15	3	-	37	53	1	-	6	87	79	-	407	-
1800	55	7	35	-	-	5	3	-	20	53	-	-	6	80	47	-	311	-
1815	43	10	33	-	1	7	1	-	29	32	-	-	5	64	43	-	268	-
1830	50	5	32	-	1	9	2	-	22	37	1	-	8	44	41	-	252	-
1845	38	4	33	1	-	5	2	-	28	38	-	-	4	54	51	-	257	1
1900	47	14	22	-	-	33	4	-	20	50	1	-	-	38	36	-	265	-
1915	57	10	19	-	2	26	5	-	22	33	-	-	2	36	32	1	244	1
1930	56	11	21	-	-	22	4	-	17	31	-	-	5	36	30	-	233	-
1945	29	5	17	-	-	20	2	-	16	27	-	-	5	31	23	-	175	-
2000	34	10	28	-	-	3	5	-	20	25	-	-	3	36	20	-	184	-
2015	32	7	21	-	-	4	3	-	13	26	-	-	4	38	19	-	167	-
2030	33	6	19	-	-	6	-	-	19	20	-	-	-	35	14	-	152	-
2045	28	5	19	-	-	3	-	-	8	12	-	-	1	17	23	-	116	-
2100	36	4	15	-	-	3	-	-	11	18	-	-	1	23	7	-	118	-
2115	9	4	10	-	-	3	-	-	13	15	-	-	3	22	8	-	87	-
2130	23	3	12	-	-	1	-	-	11	15	-	-	1	13	13	-	92	-
2145	17	6	7	-	-	3	-	-	4	12	-	-	2	13	5	-	69	-
2200	13	8	10	-	-	4	3	-	5	9	-	-	5	16	6	-	79	-
2215	8	2	6	-	-	3	3	-	8	10	1	-	-	7	8	-	56	-
2230	6	7	13	-	-	1	3	-	4	3	-	-	1	12	7	-	57	-
2245	9	-	5	1	-	1	1	-	4	3	-	-	1	12	6	-	42	1
2300	7	3	6	-	-	2	1	-	4	3	-	-	2	8	3	-	39	-
2315	6	1	8	-	-	-	1	-	4	6	-	-	1	8	2	-	37	-
2330	7	1	7	-	-	-	-	-	2	2	-	-	-	3	3	-	25	-
2345	16	2	7	-	-	-	2	-	1	-	-	-	-	1	5	-	34	-

<b>Trucks</b>	4%	3%	6%		3%	3%	2%		6%	5%	8%		1%	5%	4%		5%
---------------	----	----	----	--	----	----	----	--	----	----	----	--	----	----	----	--	----

Start Time	CR 50/Elm St EB				9th St WB				TH 3 NB				TH 3 SB				15 min Veh. Total	15 min Ped Total
	L	T	R	Ped	L	T	R	Ped	L	T	R	Ped	L	T	R	Ped		

**Peak 1** 0000 to 1000

700	41	4	12	-	-	12	8	2	25	76	3	-	5	43	59	1	288	3
715	41	9	22	-	-	25	10	-	29	63	-	-	1	49	77	-	326	-
730	51	1	13	-	1	14	6	-	46	68	-	-	1	48	56	-	305	-
745	33	6	19	-	-	22	7	-	45	50	2	-	1	54	61	-	300	-
<b>Total</b>	<b>166</b>	<b>20</b>	<b>66</b>	<b>-</b>	<b>1</b>	<b>73</b>	<b>31</b>	<b>2</b>	<b>145</b>	<b>257</b>	<b>5</b>	<b>-</b>	<b>8</b>	<b>194</b>	<b>253</b>	<b>1</b>	<b>1,219</b>	<b>3</b>
<b>PHF</b>	0.81	0.56	0.75		0.25	0.73	0.78		0.79	0.85	0.42		0.40	0.90	0.82		0.93	

**Peak 2** 1000 to 1400

1400	40	8	26	-	2	7	3	-	10	43	4	-	3	53	41	-	240	-
1415	52	6	29	-	1	7	5	1	35	41	2	1	7	46	56	-	287	2
1430	73	4	30	-	-	10	4	2	32	38	-	-	3	45	50	1	289	3
1445	39	7	20	-	1	6	5	-	31	44	-	-	2	44	38	-	237	-
<b>Total</b>	<b>204</b>	<b>25</b>	<b>105</b>	<b>-</b>	<b>4</b>	<b>30</b>	<b>17</b>	<b>3</b>	<b>108</b>	<b>166</b>	<b>6</b>	<b>1</b>	<b>15</b>	<b>188</b>	<b>185</b>	<b>1</b>	<b>1,053</b>	<b>5</b>
<b>PHF</b>	0.70	0.78	0.88		0.50	0.75	0.85		0.77	0.94	0.38		0.54	0.89	0.83		0.91	

**Peak 3** 1400 to 2400

1630	79	14	29	-	2	12	3	-	35	66	1	-	8	95	49	-	393	-
1645	70	13	58	5	-	16	5	-	31	62	-	4	4	75	82	-	416	9
1700	72	20	51	1	2	11	9	-	34	82	1	-	7	94	47	-	430	1
1715	84	14	56	4	-	10	5	-	37	80	-	-	9	67	58	1	420	5
<b>Total</b>	<b>305</b>	<b>61</b>	<b>194</b>	<b>10</b>	<b>4</b>	<b>49</b>	<b>22</b>	<b>-</b>	<b>137</b>	<b>290</b>	<b>2</b>	<b>4</b>	<b>28</b>	<b>331</b>	<b>236</b>	<b>1</b>	<b>1,659</b>	<b>15</b>
<b>PHF</b>	0.91	0.76	0.84		0.50	0.77	0.61		0.93	0.88	0.50		0.78	0.87	0.72		0.96	

# Albeck Gerken, Inc

Transportation Engineers

Traffic Data Collection

TH-3 at Co.Rd.50, north jct  
Farmington, MN  
Ref.Pt.: 026.015  
TURN MOVEMENT COUNT

File Name : 33 TH 3 & CR 50 N JCT  
Site Code : 33  
Start Date : 1/13/2012  
Page No : 1

## Groups Printed- Cars - Heavy Vehicles

Start Time	TH-3 Southbound				Elm St. Westbound				TH-3 Northbound				Co.Rd.50 Eastbound				Int. Total
	Left	Thru	Right	Peds	Left	Thru	Right	Peds	Left	Thru	Right	Peds	Left	Thru	Right	Peds	
06:00	0	18	24	0	0	16	5	0	19	44	0	0	17	2	8	0	153
06:15	1	25	39	0	0	7	7	0	26	50	0	0	36	5	15	0	211
06:30	1	35	50	0	0	10	13	0	30	65	0	0	36	2	11	0	253
06:45	1	43	54	0	0	10	9	0	13	69	0	0	19	6	16	0	240
Total	3	121	167	0	0	43	34	0	88	228	0	0	108	15	50	0	857
07:00	1	44	50	0	0	11	14	0	39	77	0	0	36	9	13	0	294
07:15	2	46	54	0	0	24	4	0	36	61	0	1	49	13	19	0	309
07:30	0	60	48	0	1	28	12	0	35	82	0	0	53	13	13	0	345
07:45	2	61	70	0	0	16	3	0	33	72	2	0	41	5	16	0	321
Total	5	211	222	0	1	79	33	0	143	292	2	1	179	40	61	0	1269
08:00	2	26	58	0	0	15	8	0	32	51	1	0	27	8	12	0	240
08:15	1	36	41	0	0	8	6	0	21	61	0	0	46	4	21	0	245
08:30	0	42	44	2	0	9	6	0	23	40	1	0	34	6	19	0	226
08:45	4	35	56	0	1	10	7	0	26	58	1	0	49	5	20	1	273
Total	7	139	199	2	1	42	27	0	102	210	3	0	156	23	72	1	984
09:00	0	30	38	2	1	7	5	0	20	41	2	0	35	2	17	0	200
09:15	0	40	26	0	1	5	4	0	25	39	1	0	33	1	27	0	202
09:30	1	38	32	0	0	8	5	0	19	37	2	0	32	6	26	0	206
09:45	3	43	25	0	0	8	1	0	25	43	0	0	24	3	19	0	194
Total	4	151	121	2	2	28	15	0	89	160	5	0	124	12	89	0	802
10:00	1	36	22	0	2	10	7	0	14	35	1	0	19	9	24	0	180
10:15	2	43	27	0	0	13	4	0	17	22	0	0	29	3	18	0	178
10:30	1	35	28	0	1	4	1	0	22	35	0	1	31	0	23	0	182
10:45	2	29	40	0	0	7	6	0	20	31	0	0	29	2	18	0	184
Total	6	143	117	0	3	34	18	0	73	123	1	1	108	14	83	0	724
11:00	0	37	31	0	0	3	2	0	21	40	0	0	39	3	19	0	195
11:15	1	28	41	0	1	6	2	0	26	55	0	0	27	5	24	0	216
11:30	2	34	29	0	1	5	6	0	25	49	1	0	44	7	32	0	235
11:45	8	50	32	0	0	7	6	0	27	55	1	1	33	5	30	0	255
Total	11	149	133	0	2	21	16	0	99	199	2	1	143	20	105	0	901
12:00	0	36	29	0	1	8	3	0	28	52	2	0	25	7	20	1	212
12:15	2	43	46	0	0	9	3	0	21	39	1	0	35	5	26	0	230
12:30	0	50	40	0	0	3	3	0	34	36	0	0	50	4	18	1	239
12:45	1	43	34	0	0	7	0	0	26	36	2	0	48	11	27	0	235
Total	3	172	149	0	1	27	9	0	109	163	5	0	158	27	91	2	916
13:00	1	42	41	1	0	9	3	0	28	45	1	0	34	8	23	0	236
13:15	1	41	38	0	0	4	3	0	20	36	1	3	37	2	25	0	211
13:30	0	41	30	1	0	3	3	0	36	40	1	0	40	8	27	1	231
13:45	0	35	30	0	1	5	2	0	20	28	0	0	41	11	34	0	207
Total	2	159	139	2	1	21	11	0	104	149	3	3	152	29	109	1	885
14:00	3	33	42	0	2	5	0	0	26	41	1	0	39	6	22	0	220
14:15	8	48	36	0	1	9	1	0	41	49	2	0	50	3	21	0	269
14:30	4	57	32	1	0	4	9	0	20	37	0	2	57	14	39	0	276
14:45	0	61	42	1	0	12	4	0	30	35	1	1	54	8	21	0	270
Total	15	199	152	2	3	30	14	0	117	162	4	3	200	31	103	0	1035
15:00	3	58	36	0	2	6	2	0	24	41	0	0	45	4	37	0	258
15:15	1	59	33	0	1	5	6	0	31	39	1	0	68	11	41	0	296
15:30	3	76	49	0	1	8	1	0	19	65	1	2	78	9	36	1	349
15:45	3	71	34	1	1	13	4	0	19	54	0	0	58	12	34	0	304
Total	10	264	152	1	5	32	13	0	93	199	2	2	249	36	148	1	1207

# Albeck Gerken, Inc

Transportation Engineers

Traffic Data Collection

TH-3 at Co.Rd.50, north jct  
Farmington, MN  
Ref.Pt.: 026.015  
TURN MOVEMENT COUNT

File Name : 33 TH 3 & CR 50 N JCT  
Site Code : 33  
Start Date : 1/13/2012  
Page No : 2

## Groups Printed- Cars - Heavy Vehicles

Start Time	TH-3 Southbound				Elm St. Westbound				TH-3 Northbound				Co.Rd.50 Eastbound				Int. Total
	Left	Thru	Right	Peds	Left	Thru	Right	Peds	Left	Thru	Right	Peds	Left	Thru	Right	Peds	
16:00	5	87	48	2	0	10	5	0	56	51	1	1	72	10	42	0	390
16:15	3	77	61	0	0	4	3	1	48	62	1	0	76	18	51	0	405
16:30	8	94	39	0	3	6	1	0	31	63	0	0	74	15	32	0	366
16:45	5	96	52	1	0	8	4	0	35	63	0	2	71	9	34	0	380
Total	21	354	200	3	3	28	13	1	170	239	2	3	293	52	159	0	1541
17:00	1	92	52	2	0	7	1	0	29	61	1	1	77	18	41	0	383
17:15	2	79	64	1	1	9	4	0	43	61	1	0	84	10	34	0	393
17:30	8	93	70	0	1	14	1	0	41	56	0	1	64	12	37	1	399
17:45	1	103	61	1	0	8	5	0	38	59	2	2	72	11	47	0	410
Total	12	367	247	4	2	38	11	0	151	237	4	4	297	51	159	1	1585
18:00	3	48	60	0	0	11	8	0	39	58	1	0	69	16	40	0	353
18:15	3	67	53	0	0	9	4	0	32	53	0	0	65	11	32	0	329
18:30	3	52	52	0	0	8	5	0	21	49	0	0	48	10	32	0	280
18:45	5	39	42	0	0	12	6	0	27	47	0	0	41	6	29	0	254
Total	14	206	207	0	0	40	23	0	119	207	1	0	223	43	133	0	1216
Grand Total	113	2635	2205	16	24	463	237	1	1457	2568	34	18	2390	393	1362	6	13922
Apprch %	2.3	53	44.4	0.3	3.3	63.9	32.7	0.1	35.7	63	0.8	0.4	57.6	9.5	32.8	0.1	
Total %	0.8	18.9	15.8	0.1	0.2	3.3	1.7	0	10.5	18.4	0.2	0.1	17.2	2.8	9.8	0	
Cars	103	2486	2088	15	24	447	230	1	1345	2386	31	17	2269	380	1289	5	13116
% Cars	91.2	94.3	94.7	93.8	100	96.5	97	100	92.3	92.9	91.2	94.4	94.9	96.7	94.6	83.3	94.2
Heavy Vehicles	10	149	117	1	0	16	7	0	112	182	3	1	121	13	73	1	806
% Heavy Vehicles	8.8	5.7	5.3	6.2	0	3.5	3	0	7.7	7.1	8.8	5.6	5.1	3.3	5.4	16.7	5.8

# Albeck Gerken, Inc

Transportation Engineers

Traffic Data Collection

TH-3 at Co.Rd.50, north jct  
Farmington, MN  
Ref.Pt.: 026.015  
TURN MOVEMENT COUNT

File Name : 33 TH 3 & CR 50 N JCT  
Site Code : 33  
Start Date : 1/13/2012  
Page No : 3

Start Time	TH-3 Southbound					Elm St. Westbound					TH-3 Northbound					Co.Rd.50 Eastbound					Int. Total
	Left	Thru	Right	Peds	App. Total	Left	Thru	Right	Peds	App. Total	Left	Thru	Right	Peds	App. Total	Left	Thru	Right	Peds	App. Total	
Peak Hour Analysis From 06:00 to 09:00 - Peak 1 of 1																					
Peak Hour for Entire Intersection Begins at 07:00																					
07:00	1	44	50	0	95	0	11	14	0	25	39	77	0	0	116	36	9	13	0	58	294
07:15	2	46	54	0	102	0	24	4	0	28	36	61	0	1	98	49	13	19	0	81	309
07:30	0	60	48	0	108	1	28	12	0	41	35	82	0	0	117	53	13	13	0	79	345
07:45	2	61	70	0	133	0	16	3	0	19	33	72	2	0	107	41	5	16	0	62	321
Total Volume	5	211	222	0	438	1	79	33	0	113	143	292	2	1	438	179	40	61	0	280	1269
% App. Total	1.1	48.2	50.7	0		0.9	69.9	29.2	0		32.6	66.7	0.5	0.2		63.9	14.3	21.8	0		
PHF	.625	.865	.793	.000	.823	.250	.705	.589	.000	.689	.917	.890	.250	.250	.936	.844	.769	.803	.000	.864	.920

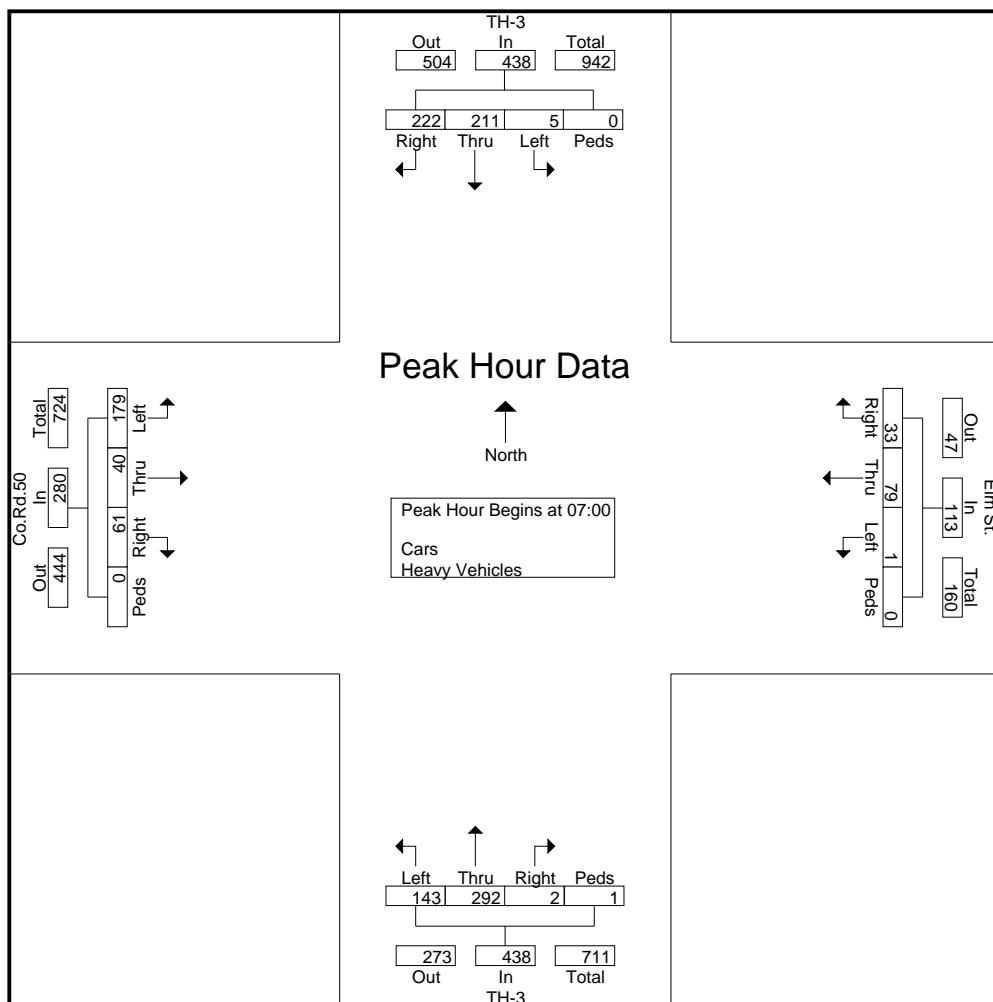

# Albeck Gerken, Inc

Transportation Engineers

Traffic Data Collection

TH-3 at Co.Rd.50, north jct  
Farmington, MN  
Ref.Pt.: 026.015  
TURN MOVEMENT COUNT

File Name : 33 TH 3 & CR 50 N JCT  
Site Code : 33  
Start Date : 1/13/2012  
Page No : 4

Start Time	TH-3 Southbound					Elm St. Westbound					TH-3 Northbound					Co.Rd.50 Eastbound					Int. Total
	Left	Thru	Right	Peds	App. Total	Left	Thru	Right	Peds	App. Total	Left	Thru	Right	Peds	App. Total	Left	Thru	Right	Peds	App. Total	
Peak Hour Analysis From 15:00 to 18:45 - Peak 1 of 1																					
Peak Hour for Entire Intersection Begins at 17:00																					
17:00	1	92	52	2	147	0	7	1	0	8	29	61	1	1	92	77	18	41	0	136	383
17:15	2	79	64	1	146	1	9	4	0	14	43	61	1	0	105	84	10	34	0	128	393
17:30	8	93	70	0	171	1	14	1	0	16	41	56	0	1	98	64	12	37	1	114	399
17:45	1	103	61	1	166	0	8	5	0	13	38	59	2	2	101	72	11	47	0	130	410
Total Volume	12	367	247	4	630	2	38	11	0	51	151	237	4	4	396	297	51	159	1	508	1585
% App. Total	1.9	58.3	39.2	0.6		3.9	74.5	21.6	0		38.1	59.8	1	1		58.5	10	31.3	0.2		
PHF	.375	.891	.882	.500	.921	.500	.679	.550	.000	.797	.878	.971	.500	.500	.943	.884	.708	.846	.250	.934	.966

