



# MINNESOTA DEPT OF TRANSPORTATION

## TRAFFIC DATA COLLECTION - METRO

TH-41 at Canyon Rd (+TH-212 Park & Ride)  
 Ref.Pt.: 003.634  
 Data by: Westwood Professional Services  
 TURN MOVEMENT COUNT

File Name : 250  
 Site Code : 25053408  
 Start Date : 10/8/2008  
 Page No : 1

### Groups Printed- Unshifted

Start Time	TH-41 Southbound				Canyon Rd Westbound				TH-41 Northbound				TH-212 Park & Ride Eastbound				Int. Total
	Left	Thru	Right	Peds	Left	Thru	Right	Peds	Left	Thru	Right	Peds	Left	Thru	Right	Peds	
06:00	2	48	13	0	1	1	1	0	4	105	1	0	2	0	1	0	179
06:15	1	58	26	0	1	0	4	0	6	140	0	0	2	0	0	0	238
06:30	0	110	17	0	3	0	4	0	15	196	1	0	6	0	2	0	354
06:45	1	129	27	0	1	1	6	0	7	198	2	0	5	0	1	0	378
Total	4	345	83	0	6	2	15	0	32	639	4	0	15	0	4	0	1149
07:00	1	155	19	0	1	0	5	0	3	246	2	0	3	0	0	0	435
07:15	0	144	17	0	1	0	2	0	8	237	2	0	6	0	1	0	418
07:30	0	133	15	0	0	0	4	0	10	261	2	0	2	0	3	0	430
07:45	0	137	14	0	2	0	7	0	3	236	1	0	3	0	1	0	404
Total	1	569	65	0	4	0	18	0	24	980	7	0	14	0	5	0	1687
08:00	2	120	4	0	1	0	4	0	0	203	0	0	1	0	1	0	336
08:15	1	130	1	0	2	0	1	0	1	212	2	0	2	0	0	0	352
08:30	3	116	2	0	3	0	4	0	1	194	2	0	2	0	0	0	327
08:45	2	138	5	0	2	1	3	0	1	202	1	0	1	0	0	0	356
Total	8	504	12	0	8	1	12	0	3	811	5	0	6	0	1	0	1371
*** BREAK ***																	
11:00	2	143	3	0	0	0	2	0	2	129	2	0	6	0	0	0	289
11:15	1	165	0	0	1	0	1	0	0	152	0	0	1	0	0	0	321
11:30	4	115	1	0	0	0	1	0	0	150	0	0	0	0	1	0	272
11:45	2	141	0	0	2	0	0	0	0	162	4	0	0	0	0	0	311
Total	9	564	4	0	3	0	4	0	2	593	6	0	7	0	1	0	1193
12:00	4	146	1	0	1	0	3	0	0	159	3	0	1	0	0	0	318
12:15	2	175	3	0	0	0	0	0	1	140	3	0	0	0	0	0	324
12:30	4	164	3	0	0	0	1	0	0	195	2	0	2	0	1	0	372
12:45	3	163	0	0	0	0	3	0	1	166	1	0	2	0	2	0	341
Total	13	648	7	0	1	0	7	0	2	660	9	0	5	0	3	0	1355
*** BREAK ***																	
15:00	2	231	5	0	0	0	0	0	2	188	4	0	1	1	4	0	438
15:15	8	245	5	0	3	0	2	0	0	204	2	0	6	0	5	0	480
15:30	1	243	4	0	3	0	2	0	0	188	1	0	6	0	3	0	451
15:45	2	268	1	0	1	0	2	0	0	243	2	0	1	0	0	0	520
Total	13	987	15	0	7	0	6	0	2	823	9	0	14	1	12	0	1889
16:00	5	235	4	0	2	0	2	0	0	203	3	0	7	0	4	0	465
16:15	7	249	5	0	1	0	0	0	1	195	0	0	11	0	15	0	484
16:30	1	246	1	0	1	1	3	0	1	225	3	0	7	0	11	0	500
16:45	4	284	5	0	2	0	3	0	0	208	1	0	9	0	3	0	519
Total	17	1014	15	0	6	1	8	0	2	831	7	0	34	0	33	0	1968
17:00	5	256	4	0	0	0	3	0	2	237	0	0	22	0	28	0	557
17:15	7	243	2	0	2	0	4	0	1	232	1	0	5	0	5	0	502
17:30	8	249	4	0	1	0	3	0	1	218	1	0	19	0	19	0	523
17:45	8	187	4	0	2	0	3	0	3	177	2	0	3	0	2	0	391
Total	28	935	14	0	5	0	13	0	7	864	4	0	49	0	54	0	1973
Grand Total	93	5566	215	0	40	4	83	0	74	6201	51	0	144	1	113	0	12585
Apprch %	1.6	94.8	3.7	0	31.5	3.1	65.4	0	1.2	98	0.8	0	55.8	0.4	43.8	0	
Total %	0.7	44.2	1.7	0	0.3	0	0.7	0	0.6	49.3	0.4	0	1.1	0	0.9	0	



# MINNESOTA DEPT OF TRANSPORTATION

## TRAFFIC DATA COLLECTION - METRO

TH-41 at Canyon Rd (+TH-212 Park & Ride)  
 Ref.Pt.: 003.634  
 Data by: Westwood Professional Services  
 TURN MOVEMENT COUNT

File Name : 250  
 Site Code : 25053408  
 Start Date : 10/8/2008  
 Page No : 2

Start Time	TH-41 Southbound					Canyon Rd Westbound					TH-41 Northbound					TH-212 Park & Ride Eastbound					Int. Total
	Left	Thru	Right	Peds	App. Total	Left	Thru	Right	Peds	App. Total	Left	Thru	Right	Peds	App. Total	Left	Thru	Right	Peds	App. Total	
Peak Hour Analysis From 06:00 to 08:45 - Peak 1 of 1																					
Peak Hour for Entire Intersection Begins at 07:00																					
07:00	1	155	19	0	175	1	0	5	0	6	3	246	2	0	251	3	0	0	0	3	435
07:15	0	144	17	0	161	1	0	2	0	3	8	237	2	0	247	6	0	1	0	7	418
07:30	0	133	15	0	148	0	0	4	0	4	10	261	2	0	273	2	0	3	0	5	430
07:45	0	137	14	0	151	2	0	7	0	9	3	236	1	0	240	3	0	1	0	4	404
Total Volume	1	569	65	0	635	4	0	18	0	22	24	980	7	0	1011	14	0	5	0	19	1687
% App. Total	0.2	89.6	10.2	0		18.2	0	81.8	0		2.4	96.9	0.7	0		73.7	0	26.3	0		
PHF	.250	.918	.855	.000	.907	.500	.000	.643	.000	.611	.600	.939	.875	.000	.926	.583	.000	.417	.000	.679	.970

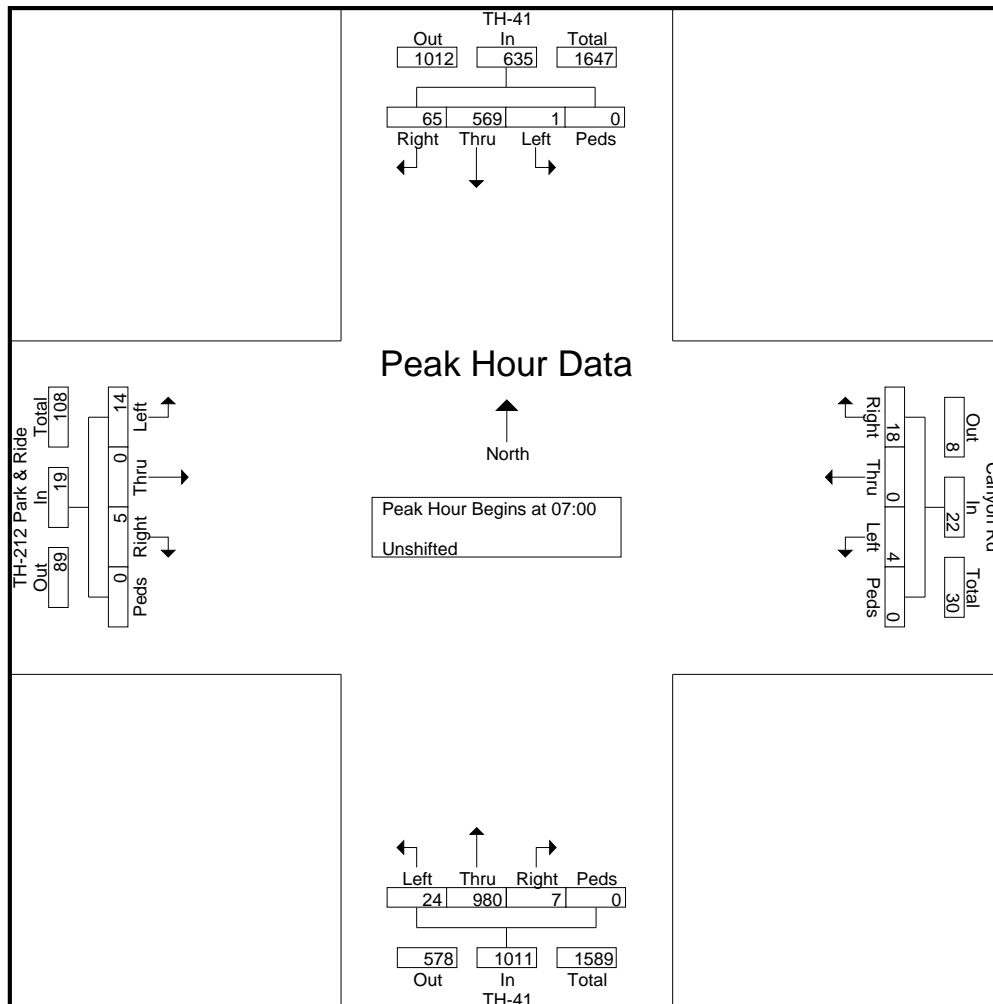



# MINNESOTA DEPT OF TRANSPORTATION

## TRAFFIC DATA COLLECTION - METRO

TH-41 at Canyon Rd (+TH-212 Park & Ride)  
 Ref.Pt.: 003.634  
 Data by: Westwood Professional Services  
 TURN MOVEMENT COUNT

File Name : 250  
 Site Code : 25053408  
 Start Date : 10/8/2008  
 Page No : 3

Start Time	TH-41 Southbound					Canyon Rd Westbound					TH-41 Northbound					TH-212 Park & Ride Eastbound					Int. Total
	Left	Thru	Right	Peds	App. Total	Left	Thru	Right	Peds	App. Total	Left	Thru	Right	Peds	App. Total	Left	Thru	Right	Peds	App. Total	
Peak Hour Analysis From 15:00 to 17:45 - Peak 1 of 1																					
Peak Hour for Entire Intersection Begins at 16:45																					
16:45	4	284	5	0	293	2	0	3	0	5	0	208	1	0	209	9	0	3	0	12	519
17:00	5	256	4	0	265	0	0	3	0	3	2	237	0	0	239	22	0	28	0	50	557
17:15	7	243	2	0	252	2	0	4	0	6	1	232	1	0	234	5	0	5	0	10	502
17:30	8	249	4	0	261	1	0	3	0	4	1	218	1	0	220	19	0	19	0	38	523
Total Volume	24	1032	15	0	1071	5	0	13	0	18	4	895	3	0	902	55	0	55	0	110	2101
% App. Total	2.2	96.4	1.4	0		27.8	0	72.2	0		0.4	99.2	0.3	0		50	0	50	0		
PHF	.750	.908	.750	.000	.914	.625	.000	.813	.000	.750	.500	.944	.750	.000	.944	.625	.000	.491	.000	.550	.943

