



# MINNESOTA DEPT OF TRANSPORTATION

TRAFFIC DATA COLLECTION - METRO

TH-41 at 82nd St. E CHASKA

File Name : TH-41 at 82nd St E CHASKA 2008

Ref.Pt.: 006.709

Site Code : 05044211

Data by: Westwood Professional Services

Start Date : 9/11/2008

TURN MOVEMENT COUNT

Page No : 1

Groups Printed- Unshifted

Start Time	TH-41 Southbound				82nd St. Westbound				TH-41 Northbound				82nd St. Eastbound				Int. Total	
	Left	Thru	Right	Peds	Left	Thru	Right	Peds	Left	Thru	Right	Peds	Left	Thru	Right	Peds		
06:00	20	67	3	0	11	0	2	0	1	31	19	0	0	1	0	0	0	155
06:15	22	63	7	0	5	0	2	0	8	54	23	0	2	1	1	0	0	188
06:30	16	67	7	0	9	1	2	0	2	85	33	0	3	2	2	0	0	229
06:45	15	86	15	0	14	2	4	0	5	49	27	0	0	2	1	0	0	220
Total	73	283	32	0	39	3	10	0	16	219	102	0	5	6	4	0	0	792
07:00	17	107	8	0	17	1	4	1	1	83	20	0	1	2	2	0	0	264
07:15	22	110	2	0	10	0	6	0	3	97	48	0	3	3	2	0	0	306
07:30	18	153	4	0	16	2	3	0	1	95	49	0	3	4	2	0	0	350
07:45	18	182	9	0	16	3	3	0	1	111	40	0	1	2	4	0	0	390
Total	75	552	23	0	59	6	16	1	6	386	157	0	8	11	10	0	0	1310
08:00	19	115	8	0	18	1	2	0	2	108	29	0	3	1	1	0	0	307
08:15	8	96	3	0	14	1	4	0	1	84	34	0	0	2	0	0	0	247
08:30	7	114	2	0	7	1	1	0	4	93	36	0	1	4	0	0	0	270
08:45	8	103	1	0	16	1	3	0	0	87	32	0	0	0	0	0	0	251
Total	42	428	14	0	55	4	10	0	7	372	131	0	4	7	1	0	0	1075
*** BREAK ***																		
11:00	6	91	2	0	23	1	6	0	1	95	12	0	0	2	2	0	0	241
11:15	9	74	2	0	20	0	5	0	1	95	25	0	8	4	3	0	0	246
11:30	8	71	1	0	24	7	14	0	2	99	27	0	3	8	2	0	0	266
11:45	8	88	1	0	25	3	8	0	1	84	23	0	3	4	5	0	0	253
Total	31	324	6	0	92	11	33	0	5	373	87	0	14	18	12	0	0	1006
12:00	5	110	0	0	30	2	10	0	6	86	24	1	2	2	3	0	0	281
12:15	7	90	2	0	17	0	8	0	4	88	18	0	1	4	0	0	0	239
12:30	13	141	10	0	26	1	6	0	4	105	17	0	1	4	2	0	0	330
12:45	11	132	0	0	25	1	8	0	2	76	24	0	1	4	0	0	0	284
Total	36	473	12	0	98	4	32	0	16	355	83	1	5	14	5	0	0	1134
*** BREAK ***																		
14:45	0	0	0	0	19	1	18	0	3	110	23	0	0	0	0	0	0	174
Total	0	0	0	0	19	1	18	0	3	110	23	0	0	0	0	0	0	174
15:00	6	99	0	0	33	5	30	0	0	140	13	0	4	0	0	0	0	330
15:15	5	106	1	0	19	3	9	0	0	110	24	0	20	4	5	0	0	306
15:30	4	63	1	0	46	5	19	0	1	139	17	0	4	2	3	0	0	304
15:45	26	61	2	0	26	1	13	0	2	121	26	0	7	2	4	0	0	291
Total	41	329	4	0	124	14	71	0	3	510	80	0	35	8	12	0	0	1231
16:00	2	88	1	0	46	0	16	0	2	142	33	0	7	0	2	0	0	339
16:15	8	87	4	0	32	5	14	0	4	133	21	0	7	5	5	0	0	325
16:30	5	100	1	0	50	2	30	0	1	173	36	0	6	1	4	0	0	409
16:45	5	105	6	0	30	3	26	0	2	141	30	0	5	1	4	0	0	358
Total	20	380	12	0	158	10	86	0	9	589	120	0	25	7	15	0	0	1431
17:00	3	105	0	0	57	1	22	0	0	150	21	0	2	2	1	0	0	364
17:15	1	124	10	0	34	2	12	0	1	143	19	0	2	1	0	0	0	349
17:30	2	117	2	0	40	1	17	0	0	148	29	0	3	0	0	0	0	359
17:45	4	95	0	0	24	1	7	0	2	115	33	0	1	0	1	0	0	283
Total	10	441	12	0	155	5	58	0	3	556	102	0	8	3	2	0	0	1355
Grand Total	328	3210	115	0	799	58	334	1	68	3470	885	1	104	74	61	0	0	9508
Apprch %	9	87.9	3.1	0	67	4.9	28	0.1	1.5	78.4	20	0	43.5	31	25.5	0	0	
Total %	3.4	33.8	1.2	0	8.4	0.6	3.5	0	0.7	36.5	9.3	0	1.1	0.8	0.6	0	0	





# MINNESOTA DEPT OF TRANSPORTATION

## TRAFFIC DATA COLLECTION - METRO

TH-41 at 82nd St. E CHASKA  
 Ref.Pt.: 006.709  
 Data by: Westwood Professional Services  
 TURN MOVEMENT COUNT

File Name : TH-41 at 82nd St E CHASKA 2008  
 Site Code : 05044211  
 Start Date : 9/11/2008  
 Page No : 3

Start Time	TH-41 Southbound					82nd St. Westbound					TH-41 Northbound					82nd St. Eastbound					Int. Total
	Left	Thru	Right	Peds	App. Total	Left	Thru	Right	Peds	App. Total	Left	Thru	Right	Peds	App. Total	Left	Thru	Right	Peds	App. Total	
Peak Hour Analysis From 06:00 to 08:45 - Peak 1 of 1																					
Peak Hour for Entire Intersection Begins at 07:15																					
07:15	22	110	2	0	134	10	0	6	0	16	3	97	48	0	148	3	3	2	0	8	306
07:30	18	153	4	0	175	16	2	3	0	21	1	95	49	0	145	3	4	2	0	9	350
07:45	18	182	9	0	209	16	3	3	0	22	1	111	40	0	152	1	2	4	0	7	390
08:00	19	115	8	0	142	18	1	2	0	21	2	108	29	0	139	3	1	1	0	5	307
Total Volume	77	560	23	0	660	60	6	14	0	80	7	411	166	0	584	10	10	9	0	29	1353
% App. Total	11.7	84.8	3.5	0		7.5	7.5	17.5	0		1.2	70.4	28.4	0		34.5	34.5	31	0		
PHF	.875	.769	.639	.000	.789	.833	.500	.583	.000	.909	.583	.926	.847	.000	.961	.833	.625	.563	.000	.806	.867

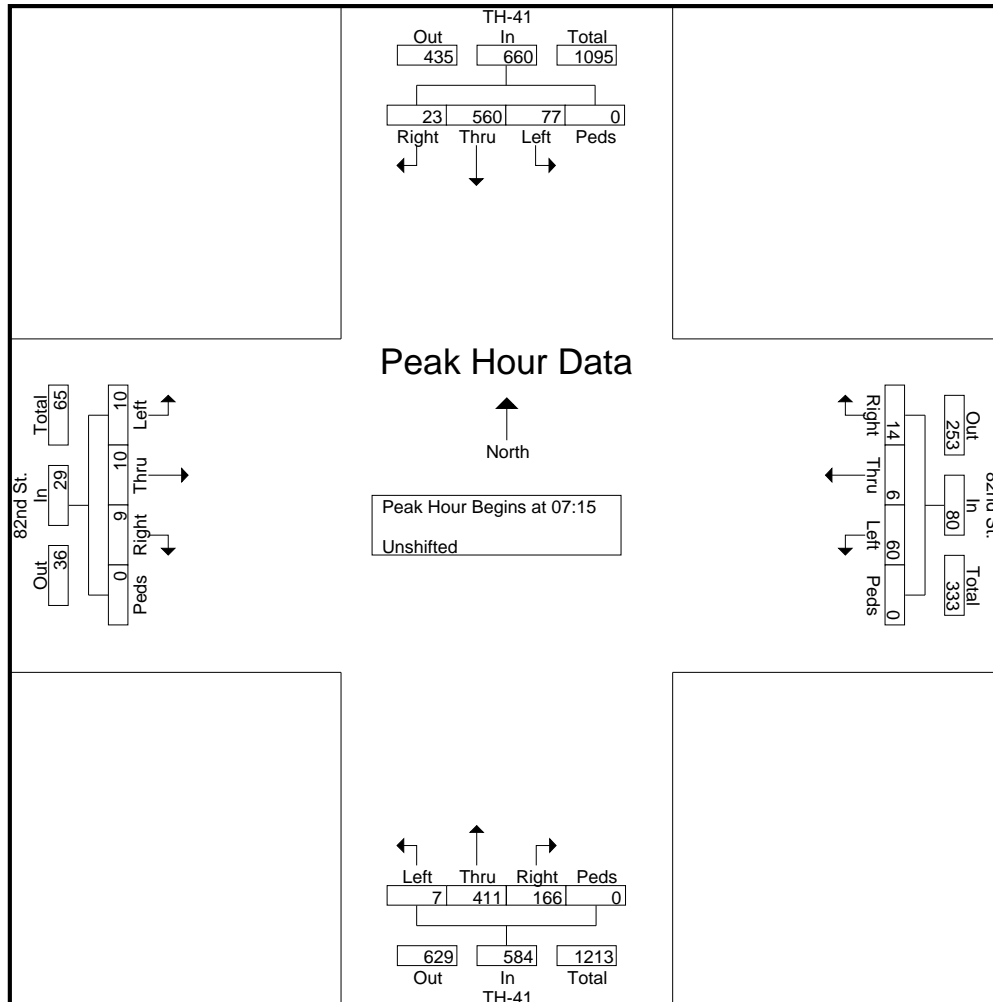



# MINNESOTA DEPT OF TRANSPORTATION

## TRAFFIC DATA COLLECTION - METRO

TH-41 at 82nd St. E CHASKA  
 Ref.Pt.: 006.709  
 Data by: Westwood Professional Services  
 TURN MOVEMENT COUNT

File Name : TH-41 at 82nd St E CHASKA 2008  
 Site Code : 05044211  
 Start Date : 9/11/2008  
 Page No : 4

Start Time	TH-41 Southbound					82nd St. Westbound					TH-41 Northbound					82nd St. Eastbound					Int. Total
	Left	Thru	Right	Peds	App. Total	Left	Thru	Right	Peds	App. Total	Left	Thru	Right	Peds	App. Total	Left	Thru	Right	Peds	App. Total	

Peak Hour Analysis From 15:00 to 17:45 - Peak 1 of 1

Peak Hour for Entire Intersection Begins at 16:30

16:30	5	100	1	0	106	50	2	30	0	82	1	173	36	0	210	6	1	4	0	11	409
16:45	5	105	6	0	116	30	3	26	0	59	2	141	30	0	173	5	1	4	0	10	358
17:00	3	105	0	0	108	57	1	22	0	80	0	150	21	0	171	2	2	1	0	5	364
17:15	1	124	10	0	135	34	2	12	0	48	1	143	19	0	163	2	1	0	0	3	349
Total Volume	14	434	17	0	465	171	8	90	0	269	4	607	106	0	717	15	5	9	0	29	1480
% App. Total	3	93.3	3.7	0		63.6	3	33.5	0		0.6	84.7	14.8	0		51.7	17.2	31	0		
PHF	.700	.875	.425	.000	.861	.750	.667	.750	.000	.820	.500	.877	.736	.000	.854	.625	.625	.563	.000	.659	.905

