

# ALLIANT ENGINEERING, INC.

733 S Marquette Ave #700, Minneapolis, MN 55402

Intersection: 49th Avenue & University Avenue  
 Date: 3/19/2024  
 Duration: 0600-1800

Site Code: 6041  
 Ref Pt: N/A  
 Page No: 1 of 4

All Vehicles (Cars & Trucks) Printed

Start Time	University Avenue Southbound						49th Avenue Westbound						University Avenue Northbound						49th Avenue Eastbound						Int. Veh. Total	Int. Ped/Bike Total
	U-Turn	Left	Thru	Right	App. Total	Peds/Bikes	U-Turn	Left	Thru	Right	App. Total	Peds/Bikes	U-Turn	Left	Thru	Right	App. Total	Peds/Bikes	U-Turn	Left	Thru	Right	App. Total	Peds/Bikes		
6:00	--	--	--	--	0	--	--	--	22	1	23	--	--	2	1	--	3	--	--	--	14	3	17	--	43	--
6:15	--	--	--	--	0	--	--	--	21	3	24	--	--	2	1	--	3	--	--	--	17	1	18	--	45	--
6:30	--	--	1	--	1	--	--	--	39	--	39	--	--	4	--	--	4	--	--	--	11	--	11	--	55	--
6:45	--	--	1	3	4	--	--	--	52	--	52	--	--	1	1	2	4	--	--	--	22	--	23	--	83	--
<b>Hour Total</b>	--	--	2	3	5	--	--	--	134	4	138	--	--	9	3	2	14	--	--	1	64	4	69	--	226	--
7:00	--	--	--	--	0	--	--	--	39	--	39	--	--	2	--	--	2	--	--	--	40	1	41	--	82	--
7:15	--	1	1	1	3	--	--	1	52	1	54	--	--	3	1	1	5	1	--	--	40	6	46	--	108	1
7:30	--	1	1	--	2	--	--	--	91	--	91	--	--	2	5	1	8	--	--	2	53	1	56	--	157	--
7:45	--	--	2	--	2	--	--	--	83	3	86	--	--	3	4	1	8	--	--	--	74	5	79	--	175	--
<b>Hour Total</b>	--	2	4	1	7	--	--	1	265	4	270	--	--	8	12	3	23	1	--	2	207	13	222	--	522	1
8:00	--	--	--	1	1	--	--	1	62	1	64	--	--	2	1	3	6	--	--	--	67	4	71	--	142	--
8:15	--	1	3	1	5	--	--	2	61	2	65	--	--	5	--	1	6	--	--	1	33	1	35	--	111	--
8:30	--	--	1	4	5	--	--	--	48	--	48	--	--	4	2	--	6	--	--	--	28	3	31	--	90	--
8:45	--	--	--	1	1	--	--	--	37	--	37	--	--	4	2	1	7	--	--	--	21	5	26	--	71	--
<b>Hour Total</b>	--	1	4	7	12	--	--	3	208	3	214	--	--	15	5	5	25	--	--	1	149	13	163	--	414	--
9:00	--	1	1	1	3	--	--	--	37	--	37	--	--	4	1	--	5	--	--	1	20	5	26	--	71	--
9:15	--	1	5	1	7	1	--	--	27	2	29	--	--	3	1	1	5	--	--	1	25	8	34	--	75	1
9:30	--	--	1	1	2	--	--	--	32	--	32	--	--	1	2	1	4	1	--	--	15	3	18	--	56	1
9:45	--	1	--	--	1	1	--	--	25	--	25	--	--	4	1	2	7	--	--	4	26	3	33	--	66	1
<b>Hour Total</b>	--	3	7	3	13	2	--	--	121	2	123	--	--	12	5	4	21	1	--	6	86	19	111	--	268	3
10:00	--	--	--	1	1	--	--	2	20	--	22	--	--	5	2	1	8	--	--	1	24	4	29	--	60	--
10:15	--	--	2	3	5	--	--	1	34	--	35	--	--	3	1	2	6	--	--	1	23	3	27	--	73	--
10:30	--	--	1	2	3	--	--	--	36	1	37	--	--	--	--	1	1	--	--	3	20	4	27	--	68	--
10:45	--	--	2	1	3	--	--	--	32	--	32	--	--	3	2	2	7	--	--	1	22	--	23	--	65	--
<b>Hour Total</b>	--	--	5	7	12	--	--	3	122	1	126	--	--	11	5	6	22	--	--	6	89	11	106	--	266	--
11:00	--	--	1	--	1	1	--	--	26	--	26	--	--	1	2	--	3	--	--	1	38	2	41	--	71	1
11:15	--	1	--	5	6	--	--	1	38	1	40	--	--	4	1	--	5	--	--	3	41	--	44	--	95	--
11:30	--	1	3	3	7	--	--	2	41	--	43	--	--	5	2	1	8	--	--	2	39	2	43	--	101	--
11:45	--	--	2	1	3	--	--	--	44	1	45	--	--	5	5	1	11	--	--	2	45	4	51	--	110	--
<b>Hour Total</b>	--	2	6	9	17	1	--	3	149	2	154	--	--	15	10	2	27	--	--	8	163	8	179	--	377	1
12:00	--	--	2	1	3	--	--	--	36	--	36	--	--	2	--	1	3	--	--	2	43	5	50	--	92	--
12:15	--	3	3	2	8	--	--	1	34	--	35	--	--	1	2	1	4	--	--	1	48	3	52	--	99	--
12:30	--	1	7	--	8	--	--	2	37	--	39	--	--	6	2	2	10	--	--	1	33	4	38	--	95	--
12:45	--	--	--	--	0	1	--	1	33	2	36	--	--	3	2	1	6	--	--	2	39	4	45	--	87	1
<b>Hour Total</b>	--	4	12	3	19	1	--	4	140	2	146	--	--	12	6	5	23	--	--	6	163	16	185	--	373	1
13:00	--	5	1	--	6	1	--	--	28	3	31	--	--	5	1	2	8	--	--	1	46	11	58	--	103	1
13:15	--	2	--	2	4	--	--	1	43	1	45	--	--	9	1	--	10	--	--	5	32	--	37	--	96	--
13:30	--	--	1	3	4	--	--	--	50	--	50	--	--	4	1	--	5	--	--	1	40	6	47	--	106	--
13:45	--	--	3	2	5	1	--	--	40	1	41	--	--	5	3	1	9	--	--	7	44	4	55	--	110	1
<b>Hour Total</b>	--	7	5	7	19	2	--	1	161	5	167	--	--	23	6	3	32	--	--	14	162	21	197	--	415	2
14:00	--	2	1	3	6	--	--	1	45	3	49	--	--	7	1	1	9	--	--	1	57	8	66	--	130	--
14:15	--	--	--	6	6	1	--	2	60	2	64	--	--	4	2	2	8	--	--	1	74	8	83	--	161	1
14:30	--	1	2	2	5	--	--	--	64	1	65	--	--	4	1	2	7	--	--	3	69	9	81	--	158	--
14:45	--	2	7	2	11	--	--	--	46	2	48	--	--	4	--	1	5	--	--	2	62	2	66	--	130	--
<b>Hour Total</b>	--	5	10	13	28	1	--	3	215	8	226	--	--	19	4	6	29	--	--	7	262	27	296	--	579	1
15:00	--	--	3	2	5	2	--	--	50	1	51	--	--	5	2	4	11	--	--	2	71	--	73	--	140	2
15:15	--	2	3	2	7	--	--	1	84	3	88	1	--	2	1	3	6	2	--	1	75	5	81	--	182	3
15:30	--	1	5	--	6	--	--	1	83	--	84	--	--	4	2	6	12	--	--	3	65	6	74	--	176	--
15:45	--	--	4	2	6	3	--	--	77	1	78	--	--	8	6	2	16	--	--	2	75	3	80	--	180	3
<b>Hour Total</b>	--	3	15	6	24	5	--	2	294	5	301	1	--	19	11	15	45	2	--	8	286	14	308	--	678	8
16:00	--	3	2	4	9	--	--	--	59	--	59	--	--	6	--	4	10	--	--	4	65	2	71	--	149	--
16:15	--	1	1	1	3	--	--	1	51	1	53	--	--	7	--	1	8	1	--	3	77	7	87	--	151	1
16:30	--	--	3	5	8	1	--	--	67	--	67	--	--	4	2	2	8	--	--	1	84	6	91	--	174	1
16:45	--	--	2	2	4	1	--	--	62	1	63	--	--	3	2	3	8	1	--	4	83	5	92	--	167	2
<b>Hour Total</b>	--	4	8	12	24	2	--	1	239	2	242	--	--	20	4	10	34	2	--	12	309	20	341	--	641	4
17:00	--	3	2	5	10	2	--	--	63	1	64	1	--	3	1	1	5	--	--	4	79	7	90	--	169	3
17:15	--	--	3	8	11	--	--	1	60	2	63	2	--	5	1	2	8	--	--	4	87	3	94	--	176	2
17:30	--	2	3	2	7	--	--	1	58	2	61	--	--	3	--	--	3	--	--	1	77	5	83	--	154	--
17:45	--	1	--	1	2	3	--	--	62	3	65	--	--	7	2	--	9	--	--	1	63	2	66	--	142	3
<b>Hour Total</b>	--	6	8	16	30	5	--	2	243	8	253	3	--	18	4	3	25	--	--	10	306	17	333	--	641	8
<b>Grand Total</b>	--	37	86	87	210	19	--	23	2291	46	2360	4	--	181	75	64	320	6	--	81	2246	183	2510	--	5400	29
% of App.	0.0%	17.6%	41.0%	41.4%			0.0%	1.0%	97.1%	1.9%		0.0%	56.6%	23.4%	20.0%		0.0%	3.2%	89.5%	7.3%						
% of Total	0.0%	0.7%	1.6%	1.6%	3.9%	65.5%	0.0%	0.4%	42.4%	0.9%	43.7%	13.8%	0.0%	3.4%	1.4%	1.2%	5.9%	20.7%	0.0%	1.5%	41.6%	3.4%	46.5%	0.0%		
Cars Total	--	36	72	86	194	19	--	23	2248	44	2315	4	--	181	58	64	303	4	--	81	2208	182	2471	--	5283	27
Cars % of Movement	0.0%	97.3%	83.7%	98.9%	92.4%	70.4%	0.0%	100%	98.1%	95.7%	98.1%	14.8%	0.0%	100%	77.3%	100%	94.7%	14.8%	0.0%	100%	98.3%	99.5%	98.4%	0.0%	97.8%	
Trucks Total	--	1	14	1	16	--	--	--	43	2	45	--	--	--	17	--	17	2	--	--	38	1	39	--	117	2
Trucks % of Movement	0.0%	2.7%	16.3%	1.1%	7.6%	0.0%	0.0%	0.0%	1.9%	4.3%	1.9%	0.0%	0.0%	0.0%	22.7%	0.0%	5.3%	#####	0.0%	0.0%	1.7%	0.5%	1.6%	0.0%	2.2%	

# ALLIANT ENGINEERING, INC.

733 S Marquette Ave #700, Minneapolis, MN 55402

Intersection: 49th Avenue & University Avenue  
 Date: 3/19/2024  
 Duration: 0600-1800

Site Code: 6041  
 Ref Pt: N/A  
 Page No: 2 of 4

All Vehicles (Cars & Trucks) Printed

Start Time	University Avenue Southbound						49th Avenue Westbound						University Avenue Northbound						49th Avenue Eastbound						Int. Veh. Total	Int. Ped/Bike Total
	U-Turn	Left	Thru	Right	App. Total	Peds/Bikes	U-Turn	Left	Thru	Right	App. Total	Peds/Bikes	U-Turn	Left	Thru	Right	App. Total	Peds/Bikes	U-Turn	Left	Thru	Right	App. Total	Peds/Bikes		
7:30	--	1	1	--	2	--	--	--	91	--	91	--	--	2	5	1	8	--	--	2	53	1	56	--	157	--
7:45	--	--	2	--	2	--	--	--	83	3	86	--	--	3	4	1	8	--	--	--	74	5	79	--	175	--
8:00	--	--	--	1	1	--	--	1	62	1	64	--	--	2	1	3	6	--	--	--	67	4	71	--	142	--
8:15	--	1	3	1	5	--	--	2	61	2	65	--	--	5	--	1	6	--	--	1	33	1	35	--	111	--
Hour Total	--	2	6	2	10	--	--	3	297	6	306	--	--	12	10	6	28	--	--	3	227	11	241	--	585	--
% of App.	0.0%	20.0%	60.0%	20.0%			0.0%	1.0%	97.1%	2.0%			0.0%	42.9%	35.7%	21.4%			0.0%	1.2%	94.2%	4.6%				
% of Total	0.0%	0.3%	1.0%	0.3%	1.7%	--	0.0%	0.5%	50.8%	1.0%	52.3%	--	0.0%	2.1%	1.7%	1.0%	4.8%	--	0.0%	0.5%	38.8%	1.9%	41.2%	--		
Cars Total	--	2	4	2	8	--	--	3	291	6	300	--	--	12	8	6	26	--	--	3	222	11	236	--	570	--
Cars % of Movement	0.0%	100%	66.7%	100%	80.0%	--	0.0%	100%	98.0%	100%	98.0%	--	0.0%	100%	80.0%	100%	92.9%	--	0.0%	100%	97.8%	100%	97.9%	--	97.4%	--
Trucks Total	--	--	2	--	2	--	--	--	6	--	6	--	--	--	2	--	2	--	--	--	5	--	5	--	15	--
Trucks % of Movement	0.0%	0.0%	33.3%	0.0%	20.0%	--	0.0%	0.0%	2.0%	0.0%	2.0%	--	0.0%	0.0%	20.0%	0.0%	7.1%	--	0.0%	0.0%	2.2%	0.0%	2.1%	--	2.6%	--

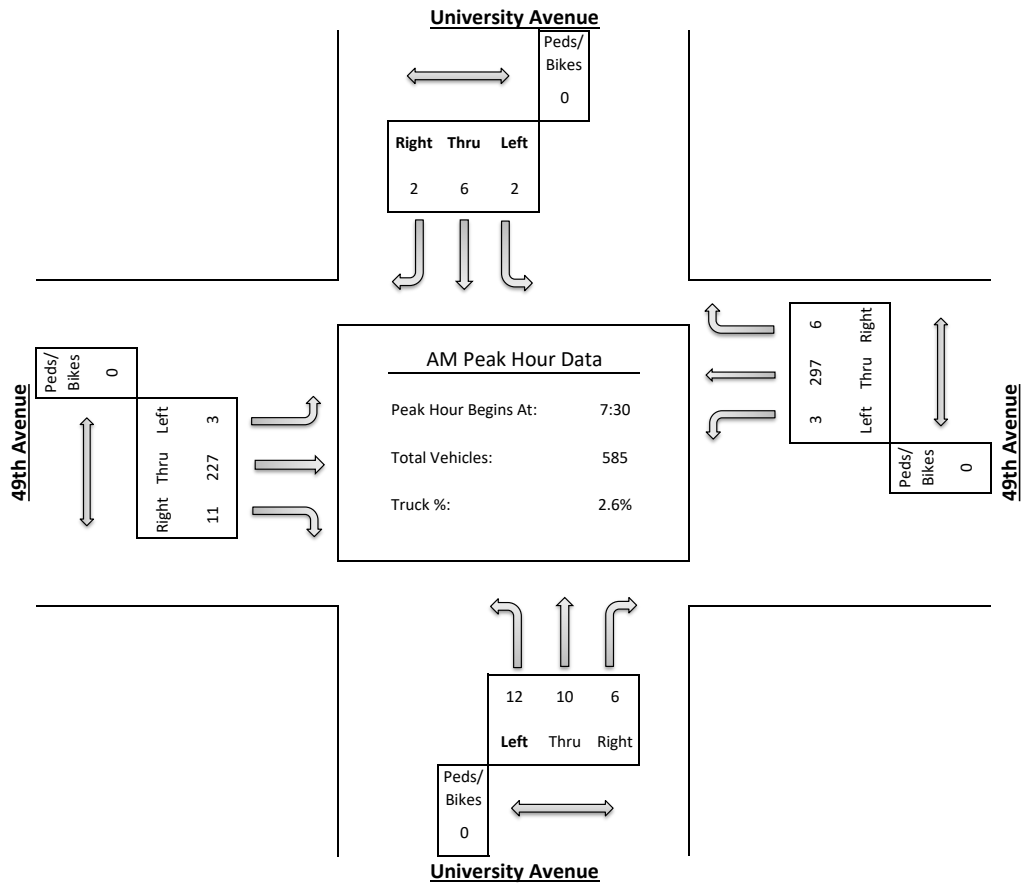

# ALLIANT ENGINEERING, INC.

733 S Marquette Ave #700, Minneapolis, MN 55402

Intersection: 49th Avenue & University Avenue  
 Date: 3/19/2024  
 Duration: 0600-1800

Site Code: 6041  
 Ref Pt: N/A  
 Page No: 3 of 4

All Vehicles (Cars & Trucks) Printed

Start Time	University Avenue Southbound						49th Avenue Westbound						University Avenue Northbound						49th Avenue Eastbound						Int. Veh. Total	Int. Ped/Bike Total
	U-Turn	Left	Thru	Right	App. Total	Peds/Bikes	U-Turn	Left	Thru	Right	App. Total	Peds/Bikes	U-Turn	Left	Thru	Right	App. Total	Peds/Bikes	U-Turn	Left	Thru	Right	App. Total	Peds/Bikes		
11:30	--	1	3	3	7	--	--	2	41	--	43	--	--	5	2	1	8	--	--	2	39	2	43	--	101	--
11:45	--	--	2	1	3	--	--	--	44	1	45	--	--	5	5	1	11	--	--	2	45	4	51	--	110	--
12:00	--	--	2	1	3	--	--	--	36	--	36	--	--	2	--	1	3	--	--	2	43	5	50	--	92	--
12:15	--	3	3	2	8	--	--	1	34	--	35	--	--	1	2	1	4	--	--	1	48	3	52	--	99	--
Hour Total	--	4	10	7	21	--	--	3	155	1	159	--	--	13	9	4	26	--	--	7	175	14	196	--	402	--
% of App.	0.0%	19.0%	47.6%	33.3%			0.0%	1.9%	97.5%	0.6%			0.0%	50.0%	34.6%	15.4%			0.0%	3.6%	89.3%	7.1%				
% of Total	0.0%	1.0%	2.5%	1.7%	5.2%	--	0.0%	0.7%	38.6%	0.2%	39.6%	--	0.0%	3.2%	2.2%	1.0%	6.5%	--	0.0%	1.7%	43.5%	3.5%	48.8%	--		
Cars Total	--	4	9	7	20	--	--	3	153	1	157	--	--	13	8	4	25	--	--	7	173	14	194	--	396	--
Cars % of Movement	0.0%	100%	90.0%	100%	95.2%	--	0.0%	100%	98.7%	100%	98.7%	--	0.0%	100%	88.9%	100%	96.2%	--	0.0%	100%	98.9%	100%	99.0%	--	98.5%	--
Trucks Total	--	--	1	--	1	--	--	--	2	--	2	--	--	--	1	--	1	--	--	--	2	--	2	--	6	--
Trucks % of Movement	0.0%	0.0%	10.0%	0.0%	4.8%	--	0.0%	0.0%	1.3%	0.0%	1.3%	--	0.0%	0.0%	11.1%	0.0%	3.8%	--	0.0%	0.0%	1.1%	0.0%	1.0%	--	1.5%	--

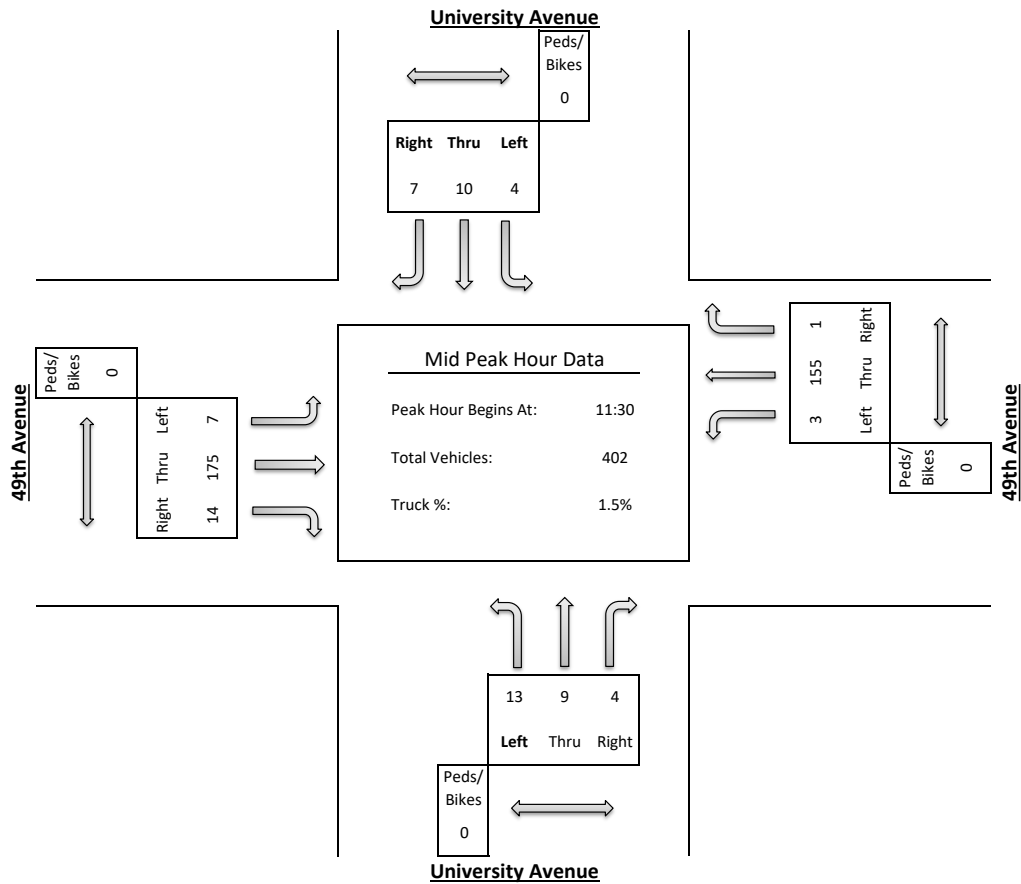

# ALLIANT ENGINEERING, INC.

733 S Marquette Ave #700, Minneapolis, MN 55402

Intersection: 49th Avenue & University Avenue  
 Date: 3/19/2024  
 Duration: 0600-1800

Site Code: 6041  
 Ref Pt: N/A  
 Page No: 4 of 4

All Vehicles (Cars & Trucks) Printed

Start Time	University Avenue Southbound						49th Avenue Westbound						University Avenue Northbound						49th Avenue Eastbound						Int. Veh. Total	Int. Ped/Bike Total
	U-Turn	Left	Thru	Right	App. Total	Peds/Bikes	U-Turn	Left	Thru	Right	App. Total	Peds/Bikes	U-Turn	Left	Thru	Right	App. Total	Peds/Bikes	U-Turn	Left	Thru	Right	App. Total	Peds/Bikes		
15:15	--	2	3	2	7	--	--	1	84	3	88	1	--	2	1	3	6	2	--	1	75	5	81	--	182	3
15:30	--	1	5	--	6	--	--	1	83	--	84	--	--	4	2	6	12	--	--	3	65	6	74	--	176	--
15:45	--	--	4	2	6	3	--	--	77	1	78	--	--	8	6	2	16	--	--	2	75	3	80	--	180	3
16:00	--	3	2	4	9	--	--	--	59	--	59	--	--	6	--	4	10	--	--	4	65	2	71	--	149	--
Hour Total	--	6	14	8	28	3	--	2	303	4	309	1	--	20	9	15	44	2	--	10	280	16	306	--	687	6
% of App.	0.0%	21.4%	50.0%	28.6%			0.0%	0.6%	98.1%	1.3%			0.0%	45.5%	20.5%	34.1%			0.0%	3.3%	91.5%	5.2%				
% of Total	0.0%	0.9%	2.0%	1.2%	4.1%	50.0%	0.0%	0.3%	44.1%	0.6%	45.0%	16.7%	0.0%	2.9%	1.3%	2.2%	6.4%	33.3%	0.0%	1.5%	40.8%	2.3%	44.5%	0.0%		
Cars Total	--	6	12	8	26	3	--	2	293	3	298	1	--	20	8	15	43	1	--	10	277	16	303	--	670	5
Cars % of Movement	0.0%	100%	85.7%	100%	92.9%	60.0%	0.0%	100%	96.7%	75.0%	96.4%	20.0%	0.0%	100%	88.9%	100%	97.7%	20.0%	0.0%	100%	98.9%	100%	99.0%	0.0%	97.5%	
Trucks Total	--	--	2	--	2	--	--	--	10	1	11	--	--	--	1	--	1	1	--	--	3	--	3	--	17	1
Trucks % of Movement	0.0%	0.0%	14.3%	0.0%	7.1%	0.0%	0.0%	0.0%	3.3%	25.0%	3.6%	0.0%	0.0%	0.0%	11.1%	0.0%	2.3%	#####	0.0%	0.0%	1.1%	0.0%	1.0%	0.0%	2.5%	

