

ALLIANT ENGINEERING, INC.

733 S Marquette Ave #700, Minneapolis, MN 55402

Intersection: TH 47 & 57th Avenue
 Date: 3/19/2024
 Duration: 0600-1800

Site Code: 608
 Ref Pt: N/A
 Page No: 1 of 4

All Vehicles (Cars & Trucks) Printed

Start Time	TH 47 Southbound						57th Avenue Westbound						TH 47 Northbound						57th Avenue Eastbound						Int. Veh. Total	Int. Ped/ Bike Total
	U-Turn	Left	Thru	Right	App. Total	Peds/ Bikes	U-Turn	Left	Thru	Right	App. Total	Peds/ Bikes	U-Turn	Left	Thru	Right	App. Total	Peds/ Bikes	U-Turn	Left	Thru	Right	App. Total	Peds/ Bikes		
6:00	--	2	123	16	141	--	--	12	--	4	16	--	--	22	87	9	118	1	--	11	2	41	54	--	329	1
6:15	--	4	131	18	153	--	--	18	4	7	29	--	--	28	71	8	107	--	--	8	3	47	58	--	347	--
6:30	--	3	211	26	240	--	--	32	8	3	43	--	1	37	123	6	167	--	--	5	2	60	67	--	517	--
6:45	1	2	169	24	196	--	--	22	5	4	31	--	--	45	191	24	260	--	--	16	3	46	65	--	552	--
Hour Total	1	11	634	84	730	--	--	84	17	18	119	--	1	132	472	47	652	1	--	40	10	194	244	--	1745	1
7:00	--	2	179	25	206	1	--	28	6	5	39	--	--	39	162	20	221	--	--	16	5	72	93	--	559	1
7:15	2	1	216	24	243	2	--	19	5	8	32	--	--	39	192	22	253	--	--	10	5	67	82	--	610	2
7:30	1	8	277	31	317	--	--	29	4	12	45	--	1	45	246	22	314	--	--	11	4	86	101	1	777	1
7:45	--	8	267	22	297	--	--	37	14	4	55	--	--	49	267	34	350	1	--	18	9	82	109	--	811	1
Hour Total	3	19	939	102	1063	3	--	113	29	29	171	--	1	172	867	98	1138	1	--	55	23	307	385	1	2757	5
8:00	--	6	201	28	235	--	--	28	16	9	53	--	--	49	210	40	299	3	--	16	12	64	92	--	679	3
8:15	--	10	221	33	264	2	--	22	10	6	38	1	--	37	199	36	272	--	--	14	11	71	96	--	670	3
8:30	--	5	180	18	203	--	--	18	9	8	35	--	--	59	186	22	267	--	--	20	6	92	118	--	623	--
8:45	--	2	187	19	208	1	--	35	10	2	47	--	1	49	236	21	307	--	--	13	8	64	85	--	647	1
Hour Total	--	23	789	98	910	3	--	103	45	25	173	1	1	194	831	119	1145	3	--	63	37	291	391	--	2619	7
9:00	--	8	191	28	227	--	--	18	9	5	32	--	--	58	175	18	251	--	--	20	10	79	109	1	619	1
9:15	--	3	153	33	189	2	--	19	3	4	26	--	--	57	181	14	252	--	--	16	7	72	95	--	562	2
9:30	--	3	173	9	185	1	--	18	7	5	30	--	--	54	161	9	224	--	--	21	11	75	107	--	546	1
9:45	--	6	160	17	183	3	--	8	12	6	26	--	--	40	188	15	243	--	--	13	5	61	79	1	531	4
Hour Total	--	20	677	87	784	6	--	63	31	20	114	--	--	209	705	56	970	--	--	70	33	287	390	2	2258	8
10:00	--	3	190	18	211	--	--	16	11	4	31	--	--	50	136	14	200	1	--	25	7	59	91	--	533	1
10:15	--	4	151	28	183	--	--	10	4	5	19	--	--	36	175	13	224	1	--	11	10	75	96	--	522	1
10:30	--	4	160	28	192	3	--	22	5	7	34	--	--	81	187	14	282	--	--	15	9	56	80	--	588	3
10:45	--	4	183	19	206	1	--	6	5	6	17	--	--	55	179	17	251	--	--	27	6	72	105	--	579	1
Hour Total	--	15	684	93	792	4	--	54	25	22	101	--	--	222	677	58	957	2	--	78	32	262	372	--	2222	6
11:00	--	3	172	27	202	4	--	8	15	5	28	--	--	64	176	9	249	1	--	21	12	78	111	--	590	5
11:15	--	7	160	30	197	2	--	6	11	3	20	--	--	71	195	12	278	3	--	25	10	81	116	--	611	5
11:30	1	3	200	42	246	--	--	14	12	11	37	--	1	79	180	11	271	1	--	26	14	96	136	1	690	2
11:45	--	5	173	29	207	--	--	11	13	6	30	--	2	95	197	12	306	4	--	21	14	101	136	--	679	4
Hour Total	1	18	705	128	852	6	--	39	51	25	115	--	3	309	748	44	1104	9	--	93	50	356	499	1	2570	16
12:00	--	5	186	39	230	1	--	14	9	6	29	--	--	87	200	12	299	2	--	33	9	91	133	--	691	3
12:15	--	4	208	38	250	--	--	20	11	9	40	--	--	84	218	13	315	2	1	40	14	111	166	--	771	2
12:30	--	5	191	32	228	1	--	19	8	8	35	--	--	92	213	15	320	1	--	32	11	111	154	--	737	2
12:45	1	10	197	23	231	--	--	14	11	4	29	--	--	79	223	7	309	1	--	30	8	91	129	--	698	1
Hour Total	1	24	782	132	939	2	--	67	39	27	133	--	--	342	854	47	1243	6	1	135	42	404	582	--	2897	8
13:00	1	6	200	34	241	--	--	7	20	9	36	--	--	49	221	12	282	3	--	26	8	95	129	--	688	3
13:15	--	6	200	30	236	1	--	8	14	11	33	--	--	54	225	10	289	1	--	21	5	84	110	--	668	2
13:30	--	5	215	28	248	1	--	14	12	8	34	--	--	71	233	23	327	--	--	44	13	113	170	--	779	1
13:45	1	7	230	27	265	1	--	17	5	10	32	--	--	81	224	11	316	--	--	49	14	92	155	--	768	1
Hour Total	2	24	845	119	990	3	--	46	51	38	135	--	--	255	903	56	1214	4	--	140	40	384	564	--	2903	7
14:00	--	7	221	37	265	--	--	21	18	7	46	--	2	60	257	17	336	1	--	63	22	105	190	1	837	2
14:15	--	5	246	35	286	--	--	11	8	8	27	--	1	47	275	23	346	1	--	27	9	72	108	--	767	1
14:30	--	9	287	26	322	5	--	23	10	14	47	--	3	85	291	31	410	2	--	53	16	112	181	--	960	7
14:45	--	11	261	37	309	2	--	21	13	9	43	--	1	86	313	42	442	1	--	35	16	81	132	--	926	3
Hour Total	--	32	1015	135	1182	7	--	76	49	38	163	--	7	278	1136	113	1534	5	--	178	63	370	611	1	3490	13
15:00	--	4	242	30	276	1	--	31	12	16	59	--	--	77	329	34	440	1	--	40	16	103	159	--	934	2
15:15	--	8	284	40	332	--	--	23	18	18	59	--	1	80	304	18	403	3	--	53	26	96	175	--	969	3
15:30	--	7	296	34	337	3	--	29	11	10	50	--	2	62	291	23	378	--	--	43	25	118	186	--	951	3
15:45	--	8	210	39	257	--	--	18	22	17	57	--	2	73	281	33	389	1	--	44	25	93	162	--	865	1
Hour Total	--	27	1032	143	1202	4	--	101	63	61	225	--	5	292	1205	108	1610	5	--	180	92	410	682	--	3719	9
16:00	1	18	300	45	364	2	--	18	18	14	50	--	--	61	310	31	402	--	--	36	17	93	146	--	962	2
16:15	--	14	265	42	321	--	--	24	7	7	38	--	1	69	304	19	393	1	--	42	12	91	145	--	897	1
16:30	--	7	253	43	303	--	--	28	22	14	64	--	--	65	311	34	410	1	--	46	21	95	162	--	939	1
16:45	--	5	264	36	305	--	--	17	18	15	50	--	--	71	288	29	388	--	--	39	23	66	128	--	871	--
Hour Total	1	44	1082	166	1293	2	--	87	65	50	202	--	1	266	1213	113	1593	2	--	163	73	345	581	--	3669	4
17:00	--	12	271	37	320	2	--	23	20	12	55	--	--	79	261	26	366	3	--	44	21	74	139	--	880	5
17:15	--	10	239	32	281	--	--	19	11	8	38	--	--	98	278	29	405	--	--	36	15	78	129	--	853	--
17:30	--	7	218	30	255	--	--	14	19	11	44	--	--	87	308	27	422	--	--	50	21	96	167	--	888	--
17:45	1	12	215	35	263	1	--	20	14	8	42	--	--	86	229	25	340	--	--	38	13	77	128	--	773	1
Hour Total	1	41	943	134	1119	3	--	76	64	39	179	--	--	350	1076	107	1533	3	--	168	70	325	563	--	3394	6
Grand Total	10	298	10127	1421	11856	43	--	909	529	392	1830	1	19	3021	10687	966	14693	41	1	1363	565	3935	5864	5	34243	90
% of App.	0.1%	2.5%	85.4%	12.0%			0.0%	49.7%	28.9%	21.4%			0.1%	20.6%	72.7%	6.6%										

ALLIANT ENGINEERING, INC.

733 S Marquette Ave #700, Minneapolis, MN 55402

Intersection: TH 47 & 57th Avenue
 Date: 3/19/2024
 Duration: 0600-1800

Site Code: 608
 Ref Pt: N/A
 Page No: 2 of 4

All Vehicles (Cars & Trucks) Printed

Start Time	TH 47 Southbound						57th Avenue Westbound						TH 47 Northbound						57th Avenue Eastbound						Int. Veh. Total	Int. Ped/Bike Total
	U-Turn	Left	Thru	Right	App. Total	Peds/Bikes	U-Turn	Left	Thru	Right	App. Total	Peds/Bikes	U-Turn	Left	Thru	Right	App. Total	Peds/Bikes	U-Turn	Left	Thru	Right	App. Total	Peds/Bikes		
7:30	1	8	277	31	317	--	--	29	4	12	45	--	1	45	246	22	314	--	--	11	4	86	101	1	777	1
7:45	--	8	267	22	297	--	--	37	14	4	55	--	--	49	267	34	350	1	--	18	9	82	109	--	811	1
8:00	--	6	201	28	235	--	--	28	16	9	53	--	--	49	210	40	299	3	--	16	12	64	92	--	679	3
8:15	--	10	221	33	264	2	--	22	10	6	38	1	--	37	199	36	272	--	--	14	11	71	96	--	670	3
Hour Total	1	32	966	114	1113	2	--	116	44	31	191	1	1	180	922	132	1235	4	--	59	36	303	398	1	2937	8
% of App.	0.1%	2.9%	86.8%	10.2%			0.0%	60.7%	23.0%	16.2%			0.1%	14.6%	74.7%	10.7%			0.0%	14.8%	9.0%	76.1%				
% of Total	0.0%	1.1%	32.9%	3.9%	37.9%	25.0%	0.0%	3.9%	1.5%	1.1%	6.5%	12.5%	0.0%	6.1%	31.4%	4.5%	42.0%	50.0%	0.0%	2.0%	1.2%	10.3%	13.6%	12.5%		
Cars Total	1	32	924	113	1070	2	--	114	41	31	186	1	1	166	878	131	1176	4	--	56	34	285	375	1	2807	8
Cars % of Movement	100%	100%	95.7%	99.1%	96.1%	25.0%	0.0%	98.3%	93.2%	100%	97.4%	12.5%	100%	92.2%	95.2%	99.2%	95.2%	50.0%	0.0%	94.9%	94.4%	94.1%	94.2%	12.5%	95.6%	
Trucks Total	--	--	42	1	43	--	--	2	3	--	5	--	--	14	44	1	59	--	--	3	2	18	23	--	130	--
Trucks % of Movement	0.0%	0.0%	4.3%	0.9%	3.9%	--	0.0%	1.7%	6.8%	0.0%	2.6%	--	0.0%	7.8%	4.8%	0.8%	4.8%	--	0.0%	5.1%	5.6%	5.9%	5.8%	--	4.4%	

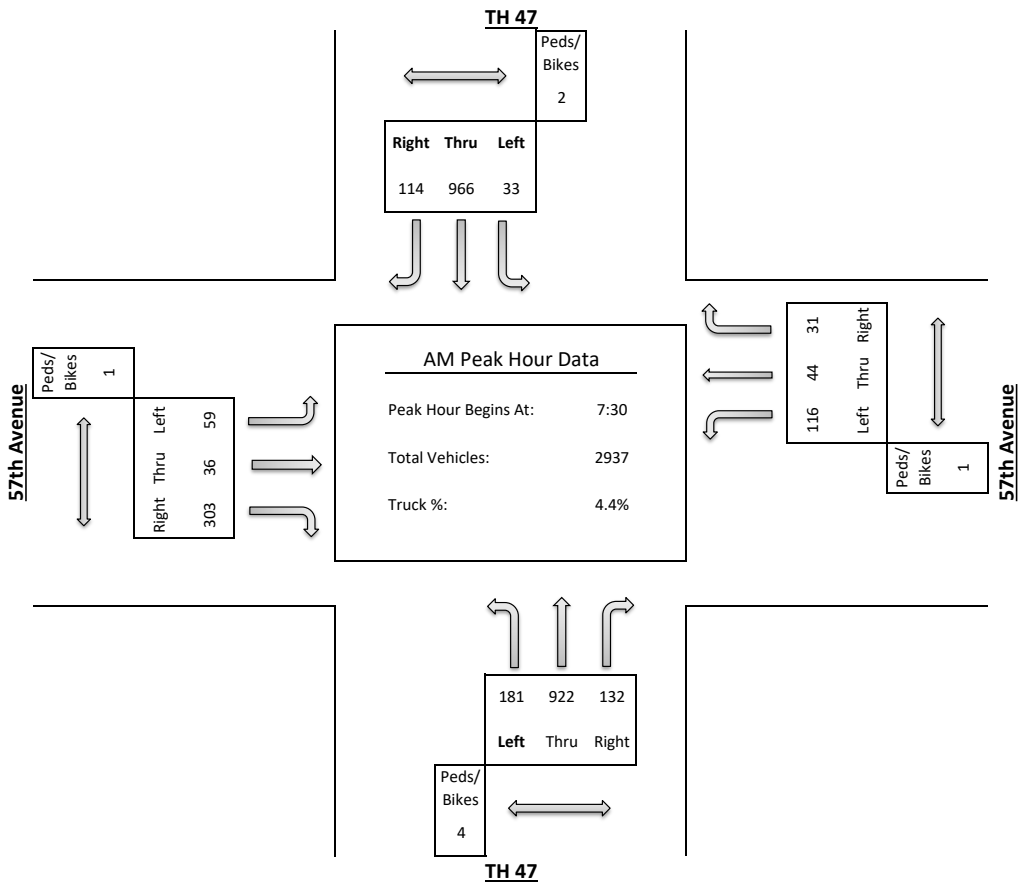

ALLIANT ENGINEERING, INC.

733 S Marquette Ave #700, Minneapolis, MN 55402

Intersection: TH 47 & 57th Avenue
 Date: 3/19/2024
 Duration: 0600-1800

Site Code: 608
 Ref Pt: N/A
 Page No: 3 of 4

All Vehicles (Cars & Trucks) Printed

Start Time	TH 47 Southbound						57th Avenue Westbound						TH 47 Northbound						57th Avenue Eastbound						Int. Veh. Total	Int. Ped/Bike Total
	U-Turn	Left	Thru	Right	App. Total	Peds/Bikes	U-Turn	Left	Thru	Right	App. Total	Peds/Bikes	U-Turn	Left	Thru	Right	App. Total	Peds/Bikes	U-Turn	Left	Thru	Right	App. Total	Peds/Bikes		
12:00	--	5	186	39	230	1	--	14	9	6	29	--	--	87	200	12	299	2	--	33	9	91	133	--	691	3
12:15	--	4	208	38	250	--	--	20	11	9	40	--	--	84	218	13	315	2	1	40	14	111	166	--	771	2
12:30	--	5	191	32	228	1	--	19	8	8	35	--	--	92	213	15	320	1	--	32	11	111	154	--	737	2
12:45	1	10	197	23	231	--	--	14	11	4	29	--	--	79	223	7	309	1	--	30	8	91	129	--	698	1
Hour Total	1	24	782	132	939	2	--	67	39	27	133	--	--	342	854	47	1243	6	1	135	42	404	582	--	2897	8
% of App.	0.1%	2.6%	83.3%	14.1%	0.0% 50.4% 29.3% 20.3%						0.0% 27.5% 68.7% 3.8%						0.2% 23.2% 7.2% 69.4%									
% of Total	0.0%	0.8%	27.0%	4.6%	32.4%	25.0%	0.0% 2.3% 1.3% 0.9% 4.6% 0.0%						0.0% 11.8% 29.5% 1.6% 42.9% 75.0%						0.0% 4.7% 1.4% 13.9% 20.1% 0.0%							
Cars Total	1	24	735	128	888	2	--	64	39	27	130	--	--	329	812	47	1188	6	1	132	42	386	561	--	2767	8
Cars % of Movement	100%	100%	94.0%	97.0%	94.6%	25.0%	0.0% 95.5% 100% 100% 97.7% 0.0%						0.0% 96.2% 95.1% 100% 95.6% 75.0%						100% 97.8% 100% 95.5% 96.4% 0.0%						95.5%	
Trucks Total	--	--	47	4	51	--	--	3	--	--	3	--	--	13	42	--	55	--	--	3	--	18	21	--	130	--
Trucks % of Movement	0.0%	0.0%	6.0%	3.0%	5.4%	--	0.0% 4.5% 0.0% 0.0% 2.3% --						0.0% 3.8% 4.9% 0.0% 4.4% --						0.0% 2.2% 0.0% 4.5% 3.6% --						4.5%	

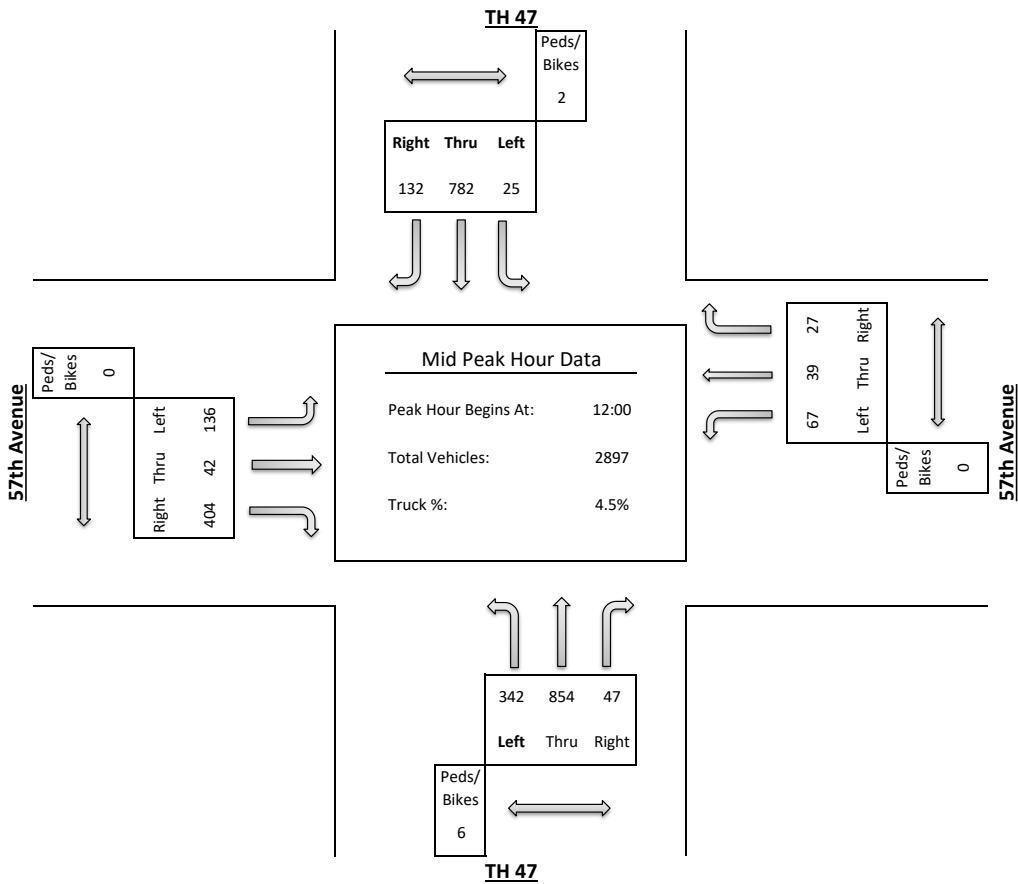

ALLIANT ENGINEERING, INC.

733 S Marquette Ave #700, Minneapolis, MN 55402

Intersection: TH 47 & 57th Avenue
 Date: 3/19/2024
 Duration: 0600-1800

Site Code: 608
 Ref Pt: N/A
 Page No: 4 of 4

All Vehicles (Cars & Trucks) Printed

Start Time	TH 47 Southbound						57th Avenue Westbound						TH 47 Northbound						57th Avenue Eastbound						Int. Veh. Total	Int. Ped/Bike Total
	U-Turn	Left	Thru	Right	App. Total	Peds/Bikes	U-Turn	Left	Thru	Right	App. Total	Peds/Bikes	U-Turn	Left	Thru	Right	App. Total	Peds/Bikes	U-Turn	Left	Thru	Right	App. Total	Peds/Bikes		
14:30	--	9	287	26	322	5	--	23	10	14	47	--	3	85	291	31	410	2	--	53	16	112	181	--	960	7
14:45	--	11	261	37	309	2	--	21	13	9	43	--	1	86	313	42	442	1	--	35	16	81	132	--	926	3
15:00	--	4	242	30	276	1	--	31	12	16	59	--	--	77	329	34	440	1	--	40	16	103	159	--	934	2
15:15	--	8	284	40	332	--	--	23	18	18	59	--	1	80	304	18	403	3	--	53	26	96	175	--	969	3
Hour Total	--	32	1074	133	1239	8	--	98	53	57	208	--	5	328	1237	125	1695	7	--	181	74	392	647	--	3789	15
% of App.	0.0%	2.6%	86.7%	10.7%			0.0%	47.1%	25.5%	27.4%			0.3%	19.4%	73.0%	7.4%			0.0%	28.0%	11.4%	60.6%				
% of Total	0.0%	0.8%	28.3%	3.5%	32.7%	53.3%	0.0%	2.6%	1.4%	1.5%	5.5%	0.0%	0.1%	8.7%	32.6%	3.3%	44.7%	46.7%	0.0%	4.8%	2.0%	10.3%	17.1%	0.0%		
Cars Total	--	31	1037	132	1200	7	--	96	52	54	202	--	5	317	1203	123	1648	7	--	180	73	375	628	--	3678	14
Cars % of Movement	0.0%	96.9%	96.6%	99.2%	96.9%	50.0%	0.0%	98.0%	98.1%	94.7%	97.1%	0.0%	100%	96.6%	97.3%	98.4%	97.2%	50.0%	0.0%	99.4%	98.6%	95.7%	97.1%	0.0%	97.1%	
Trucks Total	--	1	37	1	39	1	--	2	1	3	6	--	--	11	34	2	47	--	--	1	1	17	19	--	111	1
Trucks % of Movement	0.0%	3.1%	3.4%	0.8%	3.1%	####	0.0%	2.0%	1.9%	5.3%	2.9%	0.0%	0.0%	3.4%	2.7%	1.6%	2.8%	0.0%	0.0%	0.6%	1.4%	4.3%	2.9%	0.0%	2.9%	

