

Associated Consulting Services (ACS)
 Roseville, MN 55113
 -- TRAFFIC DATA --

MN-51 at Hillcrest Ave_2022
 City: St Paul
 Data Prepared By: ACS
 TURNING MOVEMENT COUNT

File Name : MN-51 at Hillcrest Ave_2022
 Site Code :
 Start Date : 5/3/2022
 Page No : 1

Groups Printed- Cars - Trucks

Start Time	MN-51 Southbound				Westbound				MN-51 Northbound				Hillcrest Ave Eastbound				Int. Total	
	Left	Thru	Right	Peds	Left	Thru	Right	Peds	Left	Thru	Right	Peds	Left	Thru	Right	Peds		
06:00	0	23	0	0	0	0	0	0	0	0	37	0	0	0	0	0	3	63
06:15	0	45	1	0	0	0	0	0	0	1	29	0	0	0	0	0	3	79
06:30	0	45	0	0	0	0	0	0	0	0	45	0	0	0	0	0	1	91
06:45	0	55	0	0	0	0	0	0	0	0	48	0	0	0	0	0	2	105
Total	0	168	1	0	0	0	0	0	0	1	159	0	0	0	0	0	9	338
07:00	0	65	0	1	0	0	0	0	0	1	60	0	0	0	0	1	0	128
07:15	0	88	1	0	0	0	0	0	0	0	85	0	0	0	0	0	3	177
07:30	0	80	1	0	0	0	0	0	0	0	84	0	0	0	0	1	1	167
07:45	0	107	0	0	0	0	0	0	0	1	104	0	0	0	0	2	7	221
Total	0	340	2	1	0	0	0	0	0	2	333	0	0	0	0	4	11	693
08:00	0	99	2	0	0	0	0	0	0	1	107	0	0	0	0	1	11	221
08:15	0	163	1	0	0	0	0	0	0	3	107	0	0	1	0	2	4	281
08:30	0	87	4	0	0	0	0	0	0	2	117	0	0	0	0	1	0	211
08:45	0	77	0	0	0	0	0	0	0	0	79	0	0	1	0	0	5	162
Total	0	426	7	0	0	0	0	0	0	6	410	0	0	2	0	4	20	875
09:00	0	78	2	0	0	0	0	0	0	0	66	0	0	0	0	1	0	147
09:15	0	82	1	0	0	0	0	0	0	1	102	0	0	2	0	0	0	189
09:30	0	60	1	0	0	0	0	0	0	1	93	0	0	0	0	0	0	155
09:45	0	75	1	0	0	0	0	0	0	0	66	0	1	0	0	1	4	148
Total	0	295	5	0	0	0	0	0	0	2	327	0	1	2	0	2	5	639
10:00	0	67	1	0	0	0	0	0	0	3	68	0	0	2	0	0	1	142
10:15	0	74	0	1	0	0	0	0	0	0	68	0	0	1	0	1	1	146
10:30	0	85	1	0	0	0	0	0	0	0	66	0	0	1	0	1	0	154
10:45	0	87	1	0	0	0	0	0	0	0	69	0	0	0	0	1	0	158
Total	0	313	3	1	0	0	0	0	0	3	271	0	0	4	0	3	2	600
11:00	0	66	2	0	0	0	0	0	0	1	77	0	0	0	0	0	0	146
11:15	0	80	1	0	0	0	0	0	0	0	80	0	1	0	0	0	2	164
11:30	0	83	3	0	0	0	0	0	0	0	88	0	0	0	0	0	0	174
11:45	0	80	4	0	0	0	0	0	0	0	70	0	0	3	0	0	3	160
Total	0	309	10	0	0	0	0	0	0	1	315	0	1	3	0	0	5	644
12:00	0	82	2	0	0	0	0	0	0	0	83	0	0	1	0	0	3	171
12:15	0	93	1	0	0	0	0	0	0	0	71	0	0	0	0	1	7	173
12:30	0	97	4	0	0	0	0	0	0	1	88	0	0	0	0	1	1	192
12:45	0	69	2	0	0	0	0	0	0	0	70	0	0	2	0	0	1	144
Total	0	341	9	0	0	0	0	0	0	1	312	0	0	3	0	2	12	680
13:00	0	84	2	0	0	0	0	0	0	2	86	0	0	0	0	0	0	174
13:15	0	92	0	0	0	0	0	0	0	0	84	0	0	1	0	1	2	180
13:30	0	90	0	0	0	0	0	0	0	0	80	0	0	0	0	0	3	173
13:45	0	92	0	0	0	0	0	0	0	2	99	0	0	0	0	1	0	194
Total	0	358	2	0	0	0	0	0	0	4	349	0	0	1	0	2	5	721
14:00	0	88	0	0	0	0	0	0	0	0	84	0	0	0	0	1	2	175
14:15	0	103	2	0	0	0	0	0	0	0	93	0	0	0	0	2	4	204
14:30	0	101	1	0	0	0	0	0	0	0	98	0	0	1	0	1	5	207
14:45	0	136	2	0	0	0	0	0	0	1	101	0	0	0	0	0	9	249
Total	0	428	5	0	0	0	0	0	0	1	376	0	0	1	0	4	20	835

Associated Consulting Services (ACS)
 Roseville, MN 55113
 -- TRAFFIC DATA --

MN-51 at Hillcrest Ave_2022
 City: St Paul
 Data Prepared By: ACS
 TURNING MOVEMENT COUNT

File Name : MN-51 at Hillcrest Ave_2022
 Site Code :
 Start Date : 5/3/2022
 Page No : 2

Groups Printed- Cars - Trucks

Start Time	MN-51 Southbound				Westbound				MN-51 Northbound				Hillcrest Ave Eastbound				Int. Total
	Left	Thru	Right	Peds	Left	Thru	Right	Peds	Left	Thru	Right	Peds	Left	Thru	Right	Peds	
15:00	0	153	1	0	0	0	0	0	0	124	0	0	1	0	0	32	311
15:15	0	145	2	0	0	0	0	0	1	135	0	0	0	0	0	18	301
15:30	0	127	2	0	0	0	0	0	0	114	0	0	0	0	1	4	248
15:45	0	117	1	0	0	0	0	0	2	96	0	0	0	0	1	6	223
Total	0	542	6	0	0	0	0	0	3	469	0	0	1	0	2	60	1083
16:00	0	137	2	0	0	0	0	0	0	127	0	0	0	0	2	8	276
16:15	0	107	5	0	0	0	0	0	1	114	0	0	0	0	0	3	230
16:30	0	123	3	0	0	0	0	0	0	144	0	0	0	0	0	2	272
16:45	0	136	3	0	0	0	0	0	0	129	0	0	0	0	1	4	273
Total	0	503	13	0	0	0	0	0	1	514	0	0	0	0	3	17	1051
17:00	0	129	7	0	0	0	0	0	2	131	0	0	2	0	1	13	285
17:15	0	127	1	0	0	0	0	0	0	129	0	0	0	0	1	7	265
17:30	0	132	0	0	0	0	0	0	1	130	0	2	0	0	0	4	269
17:45	0	123	1	0	0	0	0	0	0	99	0	0	0	0	0	5	228
Total	0	511	9	0	0	0	0	0	3	489	0	2	2	0	2	29	1047
Grand Total	0	4534	72	2	0	0	0	0	28	4324	0	4	19	0	28	195	9206
Apprch %	0	98.4	1.6	0	0	0	0	0	0.6	99.3	0	0.1	7.9	0	11.6	80.6	
Total %	0	49.3	0.8	0	0	0	0	0	0.3	47	0	0	0.2	0	0.3	2.1	
Cars	0	4239	68	2	0	0	0	0	26	4053	0	4	18	0	22	195	8627
% Cars	0	93.5	94.4	100	0	0	0	0	92.9	93.7	0	100	94.7	0	78.6	100	93.7
Trucks	0	295	4	0	0	0	0	0	2	271	0	0	1	0	6	0	579
% Trucks	0	6.5	5.6	0	0	0	0	0	7.1	6.3	0	0	5.3	0	21.4	0	6.3

Associated Consulting Services (ACS)
 Roseville, MN 55113
 -- TRAFFIC DATA --

MN-51 at Hillcrest Ave_2022
 City: St Paul
 Data Prepared By: ACS
 TURNING MOVEMENT COUNT

File Name : MN-51 at Hillcrest Ave_2022
 Site Code :
 Start Date : 5/3/2022
 Page No : 3

Start Time	MN-51 Southbound					Westbound					MN-51 Northbound					Hillcrest Ave Eastbound					Int. Total
	Left	Thru	Right	Peds	App. Total	Left	Thru	Right	Peds	App. Total	Left	Thru	Right	Peds	App. Total	Left	Thru	Right	Peds	App. Total	
Peak Hour Analysis From 06:00 to 11:45 - Peak 1 of 1																					
Peak Hour for Entire Intersection Begins at 07:45																					
07:45	0	107	0	0	107	0	0	0	0	0	1	104	0	0	105	0	0	2	7	9	221
08:00	0	99	2	0	101	0	0	0	0	0	1	107	0	0	108	0	0	1	11	12	221
08:15	0	163	1	0	164	0	0	0	0	0	3	107	0	0	110	1	0	2	4	7	281
08:30	0	87	4	0	91	0	0	0	0	0	2	117	0	0	119	0	0	1	0	1	211
Total Volume	0	456	7	0	463	0	0	0	0	0	7	435	0	0	442	1	0	6	22	29	934
% App. Total	0	98.5	1.5	0		0	0	0	0		1.6	98.4	0	0		3.4	0	20.7	75.9		
PHF	.000	.699	.438	.000	.706	.000	.000	.000	.000	.000	.583	.929	.000	.000	.929	.250	.000	.750	.500	.604	.831

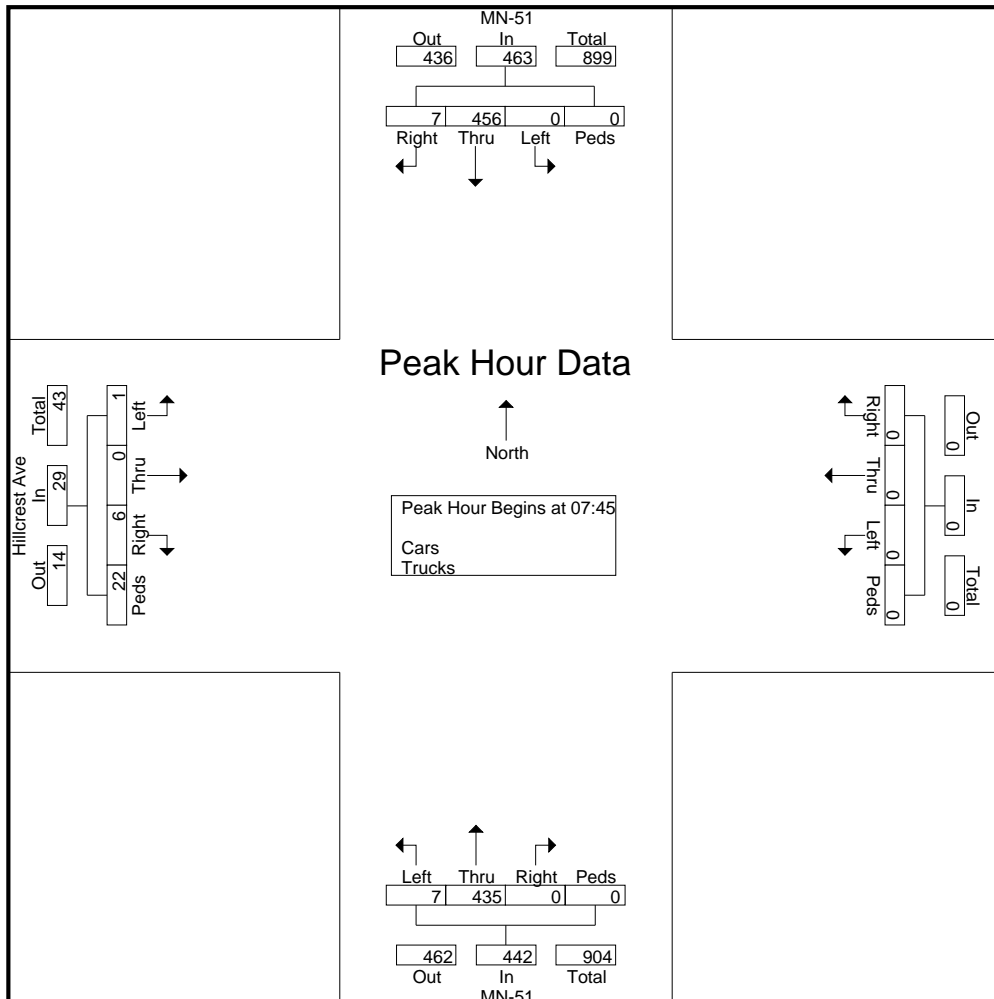

Associated Consulting Services (ACS)
 Roseville, MN 55113
 -- TRAFFIC DATA --

MN-51 at Hillcrest Ave_2022
 City: St Paul
 Data Prepared By: ACS
 TURNING MOVEMENT COUNT

File Name : MN-51 at Hillcrest Ave_2022
 Site Code :
 Start Date : 5/3/2022
 Page No : 4

Start Time	MN-51 Southbound					Westbound					MN-51 Northbound					Hillcrest Ave Eastbound					Int. Total
	Left	Thru	Right	Peds	App. Total	Left	Thru	Right	Peds	App. Total	Left	Thru	Right	Peds	App. Total	Left	Thru	Right	Peds	App. Total	
Peak Hour Analysis From 12:00 to 17:45 - Peak 1 of 1																					
Peak Hour for Entire Intersection Begins at 14:45																					
14:45	0	136	2	0	138	0	0	0	0	0	1	101	0	0	102	0	0	0	9	9	249
15:00	0	153	1	0	154	0	0	0	0	0	0	124	0	0	124	1	0	0	32	33	311
15:15	0	145	2	0	147	0	0	0	0	0	1	135	0	0	136	0	0	0	18	18	301
15:30	0	127	2	0	129	0	0	0	0	0	0	114	0	0	114	0	0	1	4	5	248
Total Volume	0	561	7	0	568	0	0	0	0	0	2	474	0	0	476	1	0	1	63	65	1109
% App. Total	0	98.8	1.2	0		0	0	0	0		0.4	99.6	0	0		1.5	0	1.5	96.9		
PHF	.000	.917	.875	.000	.922	.000	.000	.000	.000	.000	.500	.878	.000	.000	.875	.250	.000	.250	.492	.492	.891

