

Associated Consulting Services (ACS)  
Roseville, MN 55113  
-- TRAFFIC DATA --

MN-51 at Ford Pkwy\_2022

City: St Paul

Data Prepared By: ACS

TURNING MOVEMENT COUNT

File Name : MN-51 at Ford Pkwy\_2022

Site Code :

Start Date : 5/3/2022

Page No : 1

Groups Printed- Cars - Trucks

Start Time	NN-51 Southbound				Highland Arena Entrance Westbound				NN-51 Northbound				Ford Parkway Eastbound				Int. Total
	Left	Thru	Right	Peds	Left	Thru	Right	Peds	Left	Thru	Right	Peds	Left	Thru	Right	Peds	
06:00	3	18	29	0	0	0	0	1	11	20	3	1	16	0	2	4	108
06:15	0	40	25	0	0	1	0	3	9	20	1	2	11	1	6	3	122
06:30	0	44	17	0	0	0	0	2	5	36	2	2	18	0	5	0	131
06:45	1	45	37	0	0	1	3	0	8	41	0	1	18	1	6	1	163
Total	4	147	108	0	0	2	3	6	33	117	6	6	63	2	19	8	524
07:00	0	58	21	0	0	0	2	0	19	40	2	0	24	0	10	0	176
07:15	0	80	35	0	1	1	1	2	21	63	1	1	41	0	13	0	260
07:30	1	63	43	0	2	0	1	0	17	66	0	0	26	0	13	1	233
07:45	1	82	47	0	2	0	1	2	32	76	0	2	63	2	23	5	338
Total	2	283	146	0	5	1	5	4	89	245	3	3	154	2	59	6	1007
08:00	3	81	56	0	2	2	2	6	29	73	1	6	61	0	18	7	347
08:15	5	124	54	0	1	0	5	0	30	81	2	0	49	0	35	4	390
08:30	2	73	39	0	0	0	2	1	29	77	0	1	45	1	19	2	291
08:45	1	54	47	0	1	0	1	0	24	57	1	0	47	0	22	6	261
Total	11	332	196	0	4	2	10	7	112	288	4	7	202	1	94	19	1289
09:00	0	62	35	0	0	0	0	0	15	50	0	0	40	0	14	0	216
09:15	3	62	38	0	2	1	5	2	17	79	5	0	37	0	17	2	270
09:30	0	48	33	0	0	0	2	1	18	78	0	1	36	1	16	1	235
09:45	0	53	43	0	0	0	2	1	17	50	2	0	34	1	16	2	221
Total	3	225	149	0	2	1	9	4	67	257	7	1	147	2	63	5	942
10:00	0	49	39	0	2	0	0	0	16	51	1	1	55	0	14	2	230
10:15	1	62	39	0	0	0	4	0	16	52	2	0	37	1	15	1	230
10:30	3	62	42	0	0	0	4	0	19	51	1	0	52	2	25	1	262
10:45	3	66	40	0	0	1	2	0	17	49	1	1	52	0	22	1	255
Total	7	239	160	0	2	1	10	0	68	203	5	2	196	3	76	5	977
11:00	5	45	31	0	1	2	4	0	21	53	4	0	59	2	22	0	249
11:15	1	58	29	0	0	2	3	4	12	69	0	1	50	0	21	0	250
11:30	3	64	50	0	0	1	2	0	24	65	0	2	60	0	18	0	289
11:45	1	61	49	0	3	1	1	1	17	52	2	2	44	1	16	3	254
Total	10	228	159	0	4	6	10	5	74	239	6	5	213	3	77	3	1042
12:00	1	65	52	1	2	0	2	2	25	59	0	0	49	2	12	2	274
12:15	3	68	44	0	0	1	4	3	17	56	0	0	45	2	27	1	271
12:30	0	79	45	1	3	0	0	1	28	60	2	0	58	0	19	1	297
12:45	3	52	57	0	1	2	2	1	19	53	1	0	62	1	21	2	277
Total	7	264	198	2	6	3	8	7	89	228	3	0	214	5	79	6	1119
13:00	1	56	48	0	1	0	1	1	24	61	1	1	60	0	24	0	279
13:15	1	71	47	1	0	2	0	2	26	54	1	3	60	1	23	1	293
13:30	0	69	29	0	0	3	2	0	17	58	2	1	57	1	19	2	260
13:45	2	65	40	0	1	1	2	1	18	84	0	1	62	1	26	0	304
Total	4	261	164	1	2	6	5	4	85	257	4	6	239	3	92	3	1136
14:00	3	59	50	0	0	2	4	0	28	56	1	0	72	0	25	2	302
14:15	2	73	36	1	1	2	3	0	23	67	2	1	57	0	27	5	300
14:30	1	81	52	0	0	0	1	0	23	77	1	0	55	0	25	3	319
14:45	5	100	54	0	4	0	5	0	25	76	1	0	69	2	36	2	379
Total	11	313	192	1	5	4	13	0	99	276	5	1	253	2	113	12	1300

Associated Consulting Services (ACS)  
Roseville, MN 55113  
-- TRAFFIC DATA --

MN-51 at Ford Pkwy\_2022

City: St Paul

Data Prepared By: ACS

TURNING MOVEMENT COUNT

File Name : MN-51 at Ford Pkwy\_2022

Site Code :

Start Date : 5/3/2022

Page No : 2

Groups Printed- Cars - Trucks

Start Time	NN-51 Southbound				Highland Arena Entrance Westbound				NN-51 Northbound				Ford Parkway Eastbound				Int. Total
	Left	Thru	Right	Peds	Left	Thru	Right	Peds	Left	Thru	Right	Peds	Left	Thru	Right	Peds	
15:00	5	111	71	0	1	1	1	6	24	95	1	5	80	0	43	11	455
15:15	8	102	67	0	2	1	5	8	22	114	3	8	75	2	44	22	483
15:30	7	86	50	0	2	0	4	3	31	83	1	1	60	0	41	3	372
15:45	2	87	52	0	1	1	4	15	31	62	1	0	56	2	29	9	352
Total	22	386	240	0	6	3	14	32	108	354	6	14	271	4	157	45	1662
16:00	2	103	61	0	1	0	2	1	32	93	1	2	65	1	37	8	409
16:15	2	79	66	1	0	0	0	1	30	83	2	1	69	0	34	4	372
16:30	1	89	63	0	0	0	2	0	32	106	3	1	74	0	37	3	411
16:45	3	100	84	0	3	1	4	2	30	94	5	3	85	2	39	5	460
Total	8	371	274	1	4	1	8	4	124	376	11	7	293	3	147	20	1652
17:00	5	100	67	0	4	4	7	2	34	92	6	0	64	2	27	2	416
17:15	5	93	64	0	2	3	8	5	26	99	3	4	82	2	35	9	440
17:30	3	101	74	1	2	1	4	3	33	97	1	0	75	1	27	4	427
17:45	1	96	47	0	1	0	0	8	26	72	1	0	75	1	22	5	355
Total	14	390	252	1	9	8	19	18	119	360	11	4	296	6	111	20	1638
Grand Total	103	3439	2238	6	49	38	114	91	1067	3200	71	56	2541	36	1087	152	14288
Apprch %	1.8	59.4	38.7	0.1	16.8	13	39	31.2	24.3	72.8	1.6	1.3	66.6	0.9	28.5	4	
Total %	0.7	24.1	15.7	0	0.3	0.3	0.8	0.6	7.5	22.4	0.5	0.4	17.8	0.3	7.6	1.1	
Cars	100	3185	2101	6	47	38	112	91	1031	2959	70	56	2413	36	1034	152	13431
% Cars	97.1	92.6	93.9	100	95.9	100	98.2	100	96.6	92.5	98.6	100	95	100	95.1	100	94
Trucks	3	254	137	0	2	0	2	0	36	241	1	0	128	0	53	0	857
% Trucks	2.9	7.4	6.1	0	4.1	0	1.8	0	3.4	7.5	1.4	0	5	0	4.9	0	6

Associated Consulting Services (ACS)  
 Roseville, MN 55113  
 -- TRAFFIC DATA --

MN-51 at Ford Pkwy\_2022  
 City: St Paul  
 Data Prepared By: ACS  
 TURNING MOVEMENT COUNT

File Name : MN-51 at Ford Pkwy\_2022  
 Site Code :  
 Start Date : 5/3/2022  
 Page No : 3

Start Time	NN-51 Southbound					Highland Arena Entrance Westbound					NN-51 Northbound					Ford Parkway Eastbound					Int. Total
	Left	Thru	Right	Peds	App. Total	Left	Thru	Right	Peds	App. Total	Left	Thru	Right	Peds	App. Total	Left	Thru	Right	Peds	App. Total	
Peak Hour Analysis From 06:00 to 11:45 - Peak 1 of 1																					
Peak Hour for Entire Intersection Begins at 07:45																					
07:45	1	82	47	0	130	2	0	1	2	5	32	76	0	2	110	63	2	23	5	93	338
08:00	3	81	56	0	140	2	2	2	6	12	29	73	1	6	109	61	0	18	7	86	347
08:15	5	124	54	0	183	1	0	5	0	6	30	81	2	0	113	49	0	35	4	88	390
08:30	2	73	39	0	114	0	0	2	1	3	29	77	0	1	107	45	1	19	2	67	291
Total Volume	11	360	196	0	567	5	2	10	9	26	120	307	3	9	439	218	3	95	18	334	1366
% App. Total	1.9	63.5	34.6	0		19.2	7.7	38.5	34.6		27.3	69.9	0.7	2.1		65.3	0.9	28.4	5.4		
PHF	.550	.726	.875	.000	.775	.625	.250	.500	.375	.542	.938	.948	.375	.375	.971	.865	.375	.679	.643	.898	.876

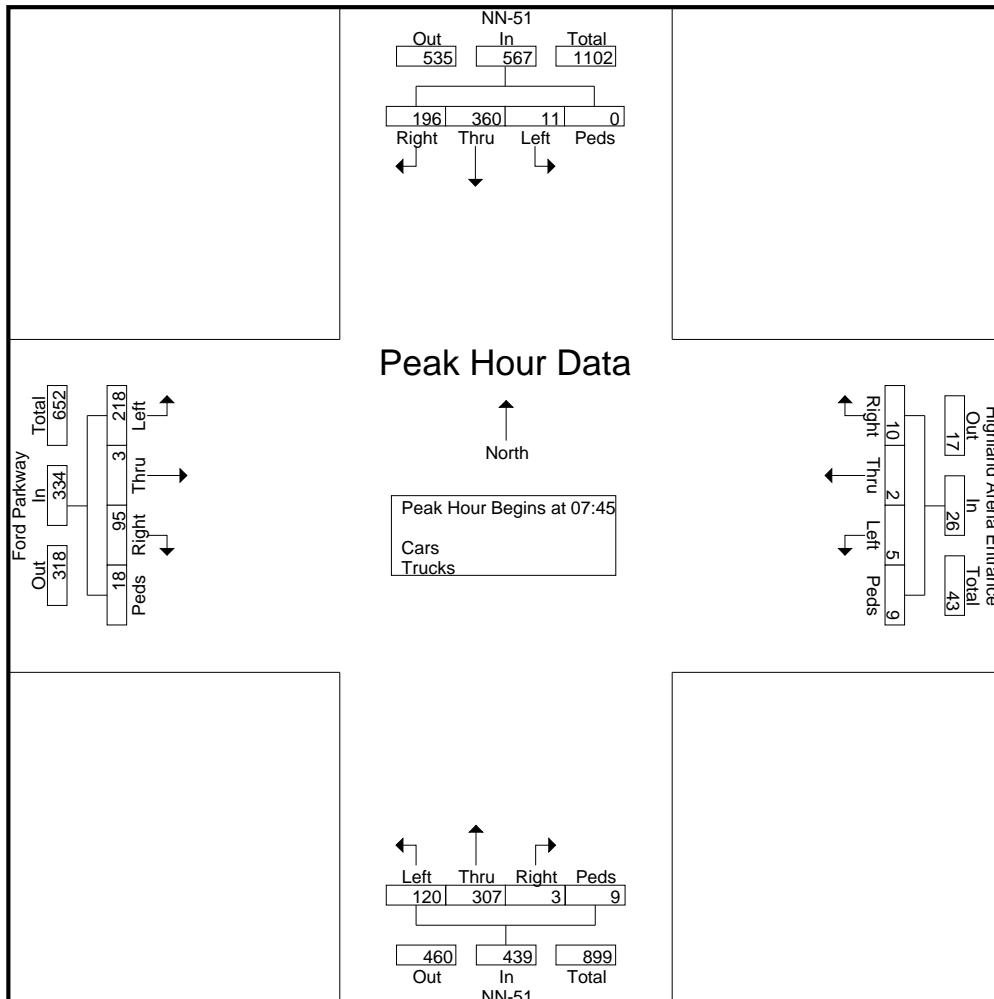

Associated Consulting Services (ACS)  
 Roseville, MN 55113  
 -- TRAFFIC DATA --

MN-51 at Ford Pkwy\_2022

City: St Paul

Data Prepared By: ACS

TURNING MOVEMENT COUNT

File Name : MN-51 at Ford Pkwy\_2022

Site Code :

Start Date : 5/3/2022

Page No : 4

Start Time	NN-51 Southbound					Highland Arena Entrance Westbound					NN-51 Northbound					Ford Parkway Eastbound					Int. Total
	Left	Thru	Right	Peds	App. Total	Left	Thru	Right	Peds	App. Total	Left	Thru	Right	Peds	App. Total	Left	Thru	Right	Peds	App. Total	
Peak Hour Analysis From 12:00 to 17:45 - Peak 1 of 1																					
Peak Hour for Entire Intersection Begins at 16:45																					
16:45	3	100	84	0	187	3	1	4	2	10	30	94	5	3	132	85	2	39	5	131	460
17:00	5	100	67	0	172	4	4	7	2	17	34	92	6	0	132	64	2	27	2	95	416
17:15	5	93	64	0	162	2	3	8	5	18	26	99	3	4	132	82	2	35	9	128	440
17:30	3	101	74	1	179	2	1	4	3	10	33	97	1	0	131	75	1	27	4	107	427
Total Volume	16	394	289	1	700	11	9	23	12	55	123	382	15	7	527	306	7	128	20	461	1743
% App. Total	2.3	56.3	41.3	0.1		20	16.4	41.8	21.8		23.3	72.5	2.8	1.3		66.4	1.5	27.8	4.3		
PHF	.800	.975	.860	.250	.936	.688	.563	.719	.600	.764	.904	.965	.625	.438	.998	.900	.875	.821	.556	.880	.947

