

SEH CONSULTING  
Traffic Data Collection  
TURN MOVEMENT COUNT

TH-51 / Snelling Ave at Co.Rd. C2  
Ref.Pt.: 008.854  
data by SEH  
TURN MOVEMENT COUNT

File Name : TH-51 at CoRd C2 2008  
Site Code : 00000023  
Start Date : 11/19/2008  
Page No : 1

Groups Printed- Unshifted - Heavy Veh

Start Time	TH-51 / Snelling Ave. Southbound				Co.Rd. C2 Westbound				TH-51 / Snelling Ave. Northbound				Co.Rd. C2 Eastbound				Int. Total
	Left	Thru	Right	Peds	Left	Thru	Right	Peds	Left	Thru	Right	Peds	Left	Thru	Right	Peds	
06:00	5	117	8	0	5	0	2	0	2	23	1	0	2	1	2	0	168
06:15	5	177	15	0	3	4	8	0	1	45	3	0	1	2	0	0	264
06:30	10	274	10	0	10	2	5	0	1	73	2	0	1	2	3	0	393
06:45	10	337	16	0	3	5	2	0	0	84	2	0	5	2	2	0	468
Total	30	905	49	0	21	11	17	0	4	225	8	0	9	7	7	0	1293
07:00	21	381	18	0	11	3	5	0	1	104	3	0	2	3	8	0	560
07:15	21	509	24	0	11	9	3	0	6	131	3	0	10	2	3	0	732
07:30	14	498	23	0	18	11	6	0	6	203	1	1	9	4	9	0	803
07:45	18	469	29	0	12	30	7	0	9	187	5	0	8	7	7	0	788
Total	74	1857	94	0	52	53	21	0	22	625	12	1	29	16	27	0	2883
08:00	24	402	25	0	7	13	4	0	10	171	4	0	11	5	14	0	690
08:15	25	352	22	0	8	8	8	0	16	159	4	0	11	6	4	0	623
08:30	14	322	27	0	9	7	9	0	5	142	4	0	10	10	4	2	565
08:45	20	249	31	0	16	9	12	0	14	141	9	0	9	10	8	0	528
Total	83	1325	105	0	40	37	33	0	45	613	21	0	41	31	30	2	2406
*** BREAK ***																	
11:00	6	209	23	0	14	11	17	0	10	129	6	0	25	15	9	0	474
11:15	13	215	28	0	11	16	15	0	12	135	12	0	18	13	8	0	496
11:30	10	274	36	0	7	12	8	0	10	138	12	0	23	10	7	0	547
11:45	13	222	30	0	9	23	18	0	9	151	11	0	32	10	2	0	530
Total	42	920	117	0	41	62	58	0	41	553	41	0	98	48	26	0	2047
12:00	18	253	29	0	11	5	16	0	4	159	7	0	30	13	9	0	554
12:15	10	194	18	0	10	4	16	0	18	193	15	0	40	16	10	0	544
12:30	7	224	18	0	9	13	31	0	11	184	4	0	37	22	11	0	571
12:45	14	180	32	0	11	9	15	0	13	192	6	0	46	16	15	0	549
Total	49	851	97	0	41	31	78	0	46	728	32	0	153	67	45	0	2218
*** BREAK ***																	
15:00	12	190	23	1	9	8	31	0	11	294	8	0	46	14	14	0	661
15:15	8	179	8	0	13	6	24	0	5	299	10	1	39	7	6	0	605
15:30	7	192	13	0	7	8	26	0	8	404	13	0	30	13	7	0	728
15:45	11	218	19	0	10	14	26	0	7	380	13	1	35	13	8	0	755
Total	38	779	63	1	39	36	107	0	31	1377	44	2	150	47	35	0	2749
16:00	6	207	17	1	11	6	47	0	6	458	13	0	47	14	12	0	845
16:15	6	221	11	0	7	8	51	0	6	455	10	0	76	18	13	0	882
16:30	13	239	17	0	5	5	36	0	7	484	10	0	58	17	9	0	900
16:45	8	215	17	2	8	7	34	0	7	479	15	0	48	19	14	0	873
Total	33	882	62	3	31	26	168	0	26	1876	48	0	229	68	48	0	3500
17:00	11	265	18	0	11	9	47	0	13	464	9	0	76	16	13	0	952
17:15	15	275	9	1	11	10	28	0	11	471	13	0	65	19	13	0	941
17:30	15	250	14	0	8	13	30	0	13	436	7	0	54	10	13	0	863
17:45	10	234	13	0	13	9	36	0	16	417	13	0	59	17	3	0	840
Total	51	1024	54	1	43	41	141	0	53	1788	42	0	254	62	42	0	3596
Grand Total	400	8543	641	5	308	297	623	0	268	7785	248	3	963	346	260	2	20692
Apprch %	4.2	89.1	6.7	0.1	25.1	24.2	50.7	0	3.2	93.8	3	0	61.3	22	16.5	0.1	
Total %	1.9	41.3	3.1	0	1.5	1.4	3	0	1.3	37.6	1.2	0	4.7	1.7	1.3	0	
Unshifted	394	8473	632	5	306	296	617	0	264	7726	247	3	958	344	257	2	20524
% Unshifted	98.5	99.2	98.6	100	99.4	99.7	99	0	98.5	99.2	99.6	100	99.5	99.4	98.8	100	99.2
Heavy Veh	6	70	9	0	2	1	6	0	4	59	1	0	5	2	3	0	168
% Heavy Veh	1.5	0.8	1.4	0	0.6	0.3	1	0	1.5	0.8	0.4	0	0.5	0.6	1.2	0	0.8

SEH CONSULTING  
Traffic Data Collection  
TURN MOVEMENT COUNT

TH-51 / Snelling Ave at Co.Rd. C2  
Ref.Pt.: 008.854  
data by SEH  
TURN MOVEMENT COUNT

File Name : TH-51 at CoRd C2 2008  
Site Code : 00000023  
Start Date : 11/19/2008  
Page No : 2

Start Time	TH-51 / Snelling Ave. Southbound					Co.Rd. C2 Westbound					TH-51 / Snelling Ave. Northbound					Co.Rd. C2 Eastbound					Int. Total
	Left	Thru	Right	Peds	App. Total	Left	Thru	Right	Peds	App. Total	Left	Thru	Right	Peds	App. Total	Left	Thru	Right	Peds	App. Total	
Peak Hour Analysis From 06:00 to 08:45 - Peak 1 of 1																					
Peak Hour for Entire Intersection Begins at 07:15																					
07:15	21	<b>509</b>	24	0	<b>554</b>	11	9	3	0	23	6	131	3	0	140	10	2	3	0	15	732
07:30	14	498	23	0	535	<b>18</b>	11	6	0	35	6	<b>203</b>	1	<b>1</b>	<b>211</b>	9	4	9	0	22	<b>803</b>
07:45	18	469	<b>29</b>	0	516	12	<b>30</b>	<b>7</b>	0	<b>49</b>	9	187	<b>5</b>	0	201	8	<b>7</b>	7	0	22	788
08:00	<b>24</b>	402	25	0	451	7	13	4	0	24	<b>10</b>	171	4	0	185	<b>11</b>	5	<b>14</b>	0	<b>30</b>	690
Total Volume	77	1878	101	0	2056	48	63	20	0	131	31	692	13	1	737	38	18	33	0	89	3013
% App. Total	3.7	91.3	4.9	0		36.6	48.1	15.3	0		4.2	93.9	1.8	0.1		42.7	20.2	37.1	0		
PHF	.802	.922	.871	.000	.928	.667	.525	.714	.000	.668	.775	.852	.650	.250	.873	.864	.643	.589	.000	.742	.938

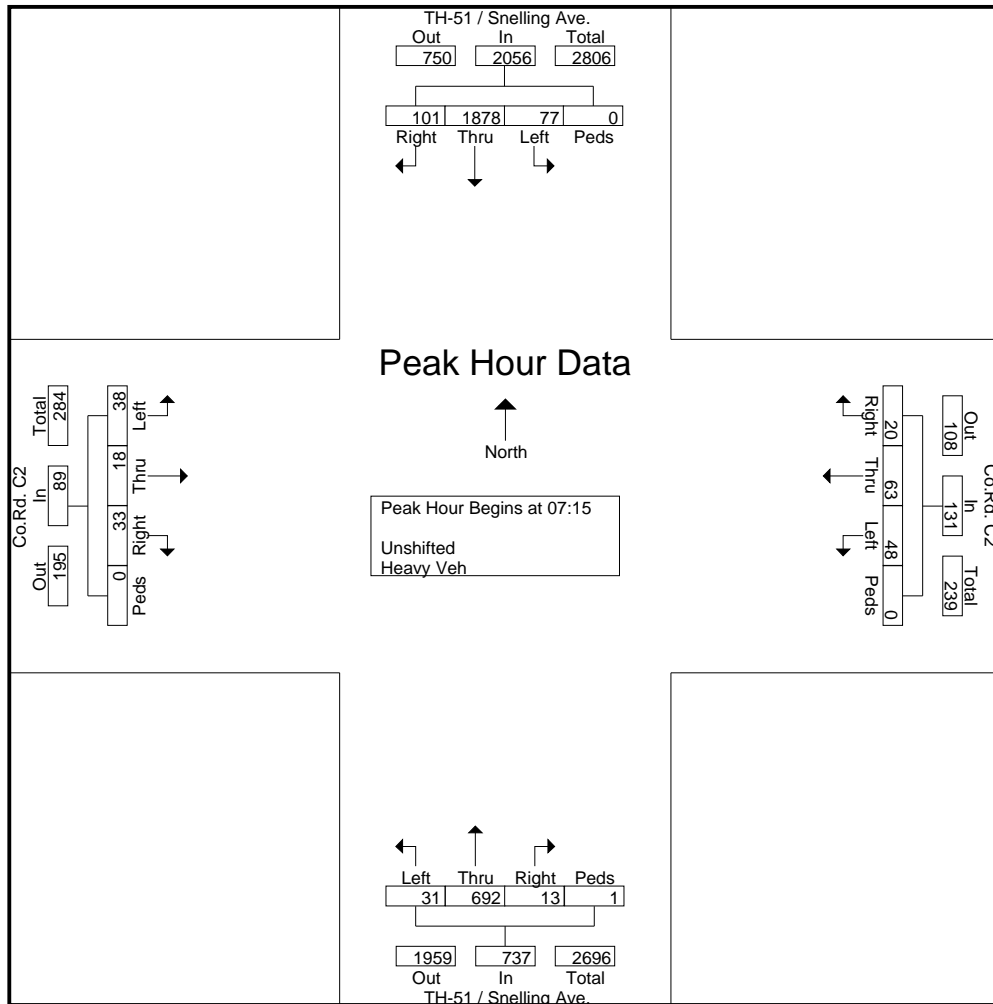

SEH CONSULTING  
Traffic Data Collection  
TURN MOVEMENT COUNT

TH-51 / Snelling Ave at Co.Rd. C2  
Ref.Pt.: 008.854  
data by SEH  
TURN MOVEMENT COUNT

File Name : TH-51 at CoRd C2 2008  
Site Code : 00000023  
Start Date : 11/19/2008  
Page No : 3

Start Time	TH-51 / Snelling Ave. Southbound					Co.Rd. C2 Westbound					TH-51 / Snelling Ave. Northbound					Co.Rd. C2 Eastbound					Int. Total
	Left	Thru	Right	Peds	App. Total	Left	Thru	Right	Peds	App. Total	Left	Thru	Right	Peds	App. Total	Left	Thru	Right	Peds	App. Total	

Peak Hour Analysis From 15:00 to 17:45 - Peak 1 of 1

Peak Hour for Entire Intersection Begins at 16:30

16:30	13	239	17	0	269	5	5	36	0	46	7	484	10	0	501	58	17	9	0	84	900
16:45	8	215	17	2	242	8	7	34	0	49	7	479	15	0	501	48	19	14	0	81	873
17:00	11	265	18	0	294	11	9	47	0	67	13	464	9	0	486	76	16	13	0	105	952
17:15	15	275	9	1	300	11	10	28	0	49	11	471	13	0	495	65	19	13	0	97	941
Total Volume	47	994	61	3	1105	35	31	145	0	211	38	1898	47	0	1983	247	71	49	0	367	3666
% App. Total	4.3	90	5.5	0.3		16.6	14.7	68.7	0		1.9	95.7	2.4	0		67.3	19.3	13.4	0		
PHF	.783	.904	.847	.375	.921	.795	.775	.771	.000	.787	.731	.980	.783	.000	.990	.813	.934	.875	.000	.874	.963

