

Alliant Engineering Inc Minneapolis, MN 55415

Rockford Rd / CSAH-9 at Dunkirk Lane

Ref.Pt.:

Alliant Engineering Inc

TURN MOVEMENT COUNT

File Name : 38_CR 24 at Dunkirk Lane_012511

Site Code : 00000038

Start Date : 1/25/2011

Page No : 1

Groups Printed- Unshifted - Bank 1

Start Time	CSAH-9 / Rockford Rd Southbound				36th Ave N Westbound				CSAH-9 / Rockford Rd Northbound				Dunkirk Lane N Eastbound				Int. Total
	Left	Thru	Right	Peds	Left	Thru	Right	Peds	Left	Thru	Right	Peds	Left	Thru	Right	Peds	
06:00	1	31	1	0	0	0	0	0	0	19	4	0	1	1	7	0	65
06:15	1	37	1	0	2	1	0	0	1	26	5	0	9	2	23	0	108
06:30	0	45	2	1	8	3	1	0	0	36	5	0	4	3	15	0	123
06:45	2	41	0	0	4	4	0	0	0	46	10	0	6	5	29	0	147
Total	4	154	4	1	14	8	1	0	1	127	24	0	20	11	74	0	443
07:00	0	58	5	0	3	8	1	0	25	49	5	0	3	11	44	0	212
07:15	3	75	1	1	2	1	1	0	6	67	8	0	9	11	54	0	239
07:30	2	81	3	0	0	2	0	0	6	104	7	0	8	23	51	0	287
07:45	2	102	6	0	4	3	0	0	8	89	24	0	14	32	47	0	331
Total	7	316	15	1	9	14	2	0	45	309	44	0	34	77	196	0	1069
08:00	5	80	3	0	8	5	0	0	11	64	13	0	4	13	54	0	260
08:15	4	73	2	0	3	6	1	0	16	70	18	0	9	7	24	0	233
08:30	5	54	3	0	4	1	1	0	9	61	11	0	3	7	21	0	180
08:45	3	59	4	1	6	0	0	0	4	43	12	0	6	11	24	0	173
Total	17	266	12	1	21	12	2	0	40	238	54	0	22	38	123	0	846
09:00	4	40	3	0	10	7	0	0	7	56	16	0	2	12	37	0	194
09:15	3	28	1	0	7	8	0	0	11	27	8	0	5	1	11	0	110
*** BREAK ***																	
Total	7	68	4	0	17	15	0	0	18	83	24	0	7	13	48	0	304
*** BREAK ***																	
10:30	0	31	3	0	8	3	1	0	9	32	12	0	1	7	12	0	119
10:45	1	38	1	0	13	8	1	0	6	26	14	0	2	3	11	0	124
Total	1	69	4	0	21	11	2	0	15	58	26	0	3	10	23	0	243
11:00	2	25	1	0	11	5	1	0	8	38	11	0	3	3	8	0	116
11:15	2	39	2	0	17	5	2	0	7	27	10	0	5	7	10	0	133
11:30	0	30	5	0	21	6	2	0	7	40	13	0	1	7	7	0	139
11:45	0	43	6	0	17	6	3	0	14	51	14	0	1	2	14	0	171
Total	4	137	14	0	66	22	8	0	36	156	48	0	10	19	39	0	559
12:00	0	42	2	0	12	7	0	0	13	45	12	0	6	4	12	0	155
12:15	1	42	4	0	11	12	3	2	12	31	13	0	0	2	11	0	144
12:30	2	47	3	0	15	2	2	0	9	52	13	0	4	4	4	0	157
12:45	1	44	4	0	8	8	1	1	10	33	13	0	2	3	8	0	136
Total	4	175	13	0	46	29	6	3	44	161	51	0	12	13	35	0	592
13:00	1	50	2	0	9	5	2	0	14	51	12	0	1	3	11	0	161
13:15	1	49	5	0	8	5	1	0	11	39	16	0	3	9	19	0	166
*** BREAK ***																	
Total	2	99	7	0	17	10	3	0	25	90	28	0	4	12	30	0	327
*** BREAK ***																	
14:30	1	52	1	0	8	11	0	0	11	64	11	0	4	4	12	0	179
14:45	2	67	0	2	13	4	0	0	21	42	13	0	3	8	17	0	192
Total	3	119	1	2	21	15	0	0	32	106	24	0	7	12	29	0	371
15:00	3	69	6	0	14	5	0	0	13	73	15	0	3	6	11	0	218
15:15	0	53	4	0	8	7	0	0	13	44	11	0	1	7	14	0	162
15:30	0	49	5	0	18	14	2	0	26	65	13	0	5	5	20	0	222
15:45	1	70	3	0	18	10	0	0	28	73	19	0	5	10	16	0	253
Total	4	241	18	0	58	36	2	0	80	255	58	0	14	28	61	0	855

Alliant Engineering Inc Minneapolis, MN 55415

Rockford Rd / CSAH-9 at Dunkirk Lane
Ref.Pt.:
Alliant Engineering Inc
TURN MOVEMENT COUNT

File Name : 38_CR 24 at Dunkirk Lane_012511
Site Code : 00000038
Start Date : 1/25/2011
Page No : 2

Groups Printed- Unshifted - Bank 1

Start Time	CSAH-9 / Rockford Rd Southbound				36th Ave N Westbound				CSAH-9 / Rockford Rd Northbound				Dunkirk Lane N Eastbound				Int. Total
	Left	Thru	Right	Peds	Left	Thru	Right	Peds	Left	Thru	Right	Peds	Left	Thru	Right	Peds	
16:00	0	77	6	0	14	11	2	0	33	96	10	0	3	11	11	0	274
16:15	2	78	7	0	24	7	4	0	32	80	13	0	6	8	22	0	283
16:30	2	86	6	0	26	13	3	0	27	107	14	0	4	12	15	0	315
16:45	0	78	8	0	29	12	4	0	42	92	14	0	3	12	22	0	316
Total	4	319	27	0	93	43	13	0	134	375	51	0	16	43	70	0	1188
17:00	2	114	4	0	25	12	9	1	45	104	14	0	5	13	13	0	361
17:15	1	111	12	0	29	17	6	0	40	91	12	0	4	12	26	0	361
17:30	1	86	7	0	26	19	1	0	37	92	10	0	6	11	23	0	319
17:45	2	85	7	0	26	22	3	0	47	61	15	0	7	13	14	0	302
Total	6	396	30	0	106	70	19	1	169	348	51	0	22	49	76	0	1343
Grand Total	63	2359	149	5	489	285	58	4	639	2306	483	0	171	325	804	0	8140
Apprch %	2.4	91.6	5.8	0.2	58.5	34.1	6.9	0.5	18.6	67.3	14.1	0	13.2	25	61.8	0	
Total %	0.8	29	1.8	0.1	6	3.5	0.7	0	7.9	28.3	5.9	0	2.1	4	9.9	0	
Unshifted	63	2294	136	5	480	273	57	4	622	2249	477	0	162	317	776	0	7915
% Unshifted	100	97.2	91.3	100	98.2	95.8	98.3	100	97.3	97.5	98.8	0	94.7	97.5	96.5	0	97.2
Bank 1	0	65	13	0	9	12	1	0	17	57	6	0	9	8	28	0	225
% Bank 1	0	2.8	8.7	0	1.8	4.2	1.7	0	2.7	2.5	1.2	0	5.3	2.5	3.5	0	2.8

Alliant Engineering Inc Minneapolis, MN 55415

Rockford Rd / CSAH-9 at Dunkirk Lane
Ref.Pt.:
Alliant Engineering Inc
TURN MOVEMENT COUNT

File Name : 38_CR 24 at Dunkirk Lane_012511
Site Code : 00000038
Start Date : 1/25/2011
Page No : 3

Start Time	CSAH-9 / Rockford Rd Southbound					36th Ave N Westbound					CSAH-9 / Rockford Rd Northbound					Dunkirk Lane N Eastbound					Int. Total
	Left	Thru	Right	Peds	App. Total	Left	Thru	Right	Peds	App. Total	Left	Thru	Right	Peds	App. Total	Left	Thru	Right	Peds	App. Total	
Peak Hour Analysis From 06:00 to 09:15 - Peak 1 of 1																					
Peak Hour for Entire Intersection Begins at 07:15																					
07:15	3	75	1	1	80	2	1	1	0	4	6	67	8	0	81	9	11	54	0	74	239
07:30	2	81	3	0	86	0	2	0	0	2	6	104	7	0	117	8	23	51	0	82	287
07:45	2	102	6	0	110	4	3	0	0	7	8	89	24	0	121	14	32	47	0	93	331
08:00	5	80	3	0	88	8	5	0	0	13	11	64	13	0	88	4	13	54	0	71	260
Total Volume	12	338	13	1	364	14	11	1	0	26	31	324	52	0	407	35	79	206	0	320	1117
% App. Total	3.3	92.9	3.6	0.3		53.8	42.3	3.8	0		7.6	79.6	12.8	0		10.9	24.7	64.4	0		
PHF	.600	.828	.542	.250	.827	.438	.550	.250	.000	.500	.705	.779	.542	.000	.841	.625	.617	.954	.000	.860	.844

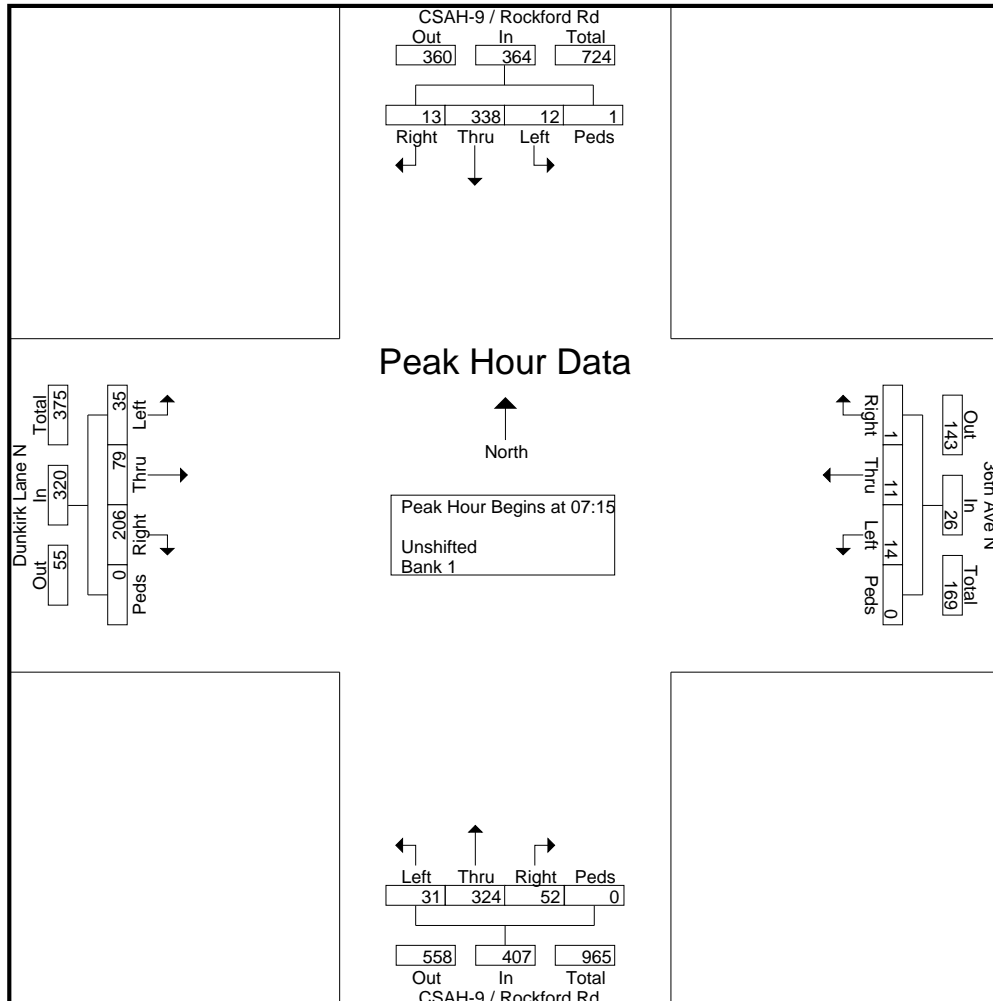

Alliant Engineering Inc Minneapolis, MN 55415

Rockford Rd / CSAH-9 at Dunkirk Lane
Ref.Pt.:
Alliant Engineering Inc
TURN MOVEMENT COUNT

File Name : 38_CR 24 at Dunkirk Lane_012511
Site Code : 00000038
Start Date : 1/25/2011
Page No : 4

Start Time	CSAH-9 / Rockford Rd Southbound					36th Ave N Westbound					CSAH-9 / Rockford Rd Northbound					Dunkirk Lane N Eastbound					Int. Total
	Left	Thru	Right	Peds	App. Total	Left	Thru	Right	Peds	App. Total	Left	Thru	Right	Peds	App. Total	Left	Thru	Right	Peds	App. Total	
Peak Hour Analysis From 14:30 to 17:45 - Peak 1 of 1																					
Peak Hour for Entire Intersection Begins at 16:45																					
16:45	0	78	8	0	86	29	12	4	0	45	42	92	14	0	148	3	12	22	0	37	316
17:00	2	114	4	0	120	25	12	9	1	47	45	104	14	0	163	5	13	13	0	31	361
17:15	1	111	12	0	124	29	17	6	0	52	40	91	12	0	143	4	12	26	0	42	361
17:30	1	86	7	0	94	26	19	1	0	46	37	92	10	0	139	6	11	23	0	40	319
Total Volume	4	389	31	0	424	109	60	20	1	190	164	379	50	0	593	18	48	84	0	150	1357
% App. Total	0.9	91.7	7.3	0		57.4	31.6	10.5	0.5		27.7	63.9	8.4	0		12	32	56	0		
PHF	.500	.853	.646	.000	.855	.940	.789	.556	.250	.913	.911	.911	.893	.000	.910	.750	.923	.808	.000	.893	.940

