



MINNESOTA DEPT OF TRANSPORTATION

TRAFFIC DATA COLLECTION - METRO

Counted By: Joanne
 Day of the Week: Wednesday
 Location: Vicksburg & 32nd Ave
 Project #: 5764

File Name : VICKSBURG LANE N @ 32nd AV N 2006
 Site Code : 07260812
 Start Date : 7/26/2006
 Page No : 1

Groups Printed- Unshifted

Start Time	Vicksburg Southbound					32nd Ave Westbound					Vicksburg Northbound					32nd Ave Eastbound					Int. Total
	Left	Thru	Right	Peds	App. Total	Left	Thru	Right	Peds	App. Total	Left	Thru	Right	Peds	App. Total	Left	Thru	Right	Peds	App. Total	
06:00	10	34	10	0	54	1	0	1	1	3	2	12	4	0	18	5	0	0	0	5	80
06:15	10	54	12	0	76	2	0	1	0	3	1	18	1	0	20	6	0	2	0	8	107
06:30	18	80	17	0	115	3	1	2	0	6	1	29	2	0	32	5	0	4	0	9	162
06:45	28	93	19	0	140	0	0	4	0	4	5	40	3	0	48	6	2	3	0	11	203
Total	66	261	58	0	385	6	1	8	1	16	9	99	10	0	118	22	2	9	0	33	552
07:00	20	114	14	0	148	0	0	3	0	3	2	41	3	0	46	6	3	0	0	9	206
07:15	12	155	22	0	189	0	0	3	0	3	4	53	5	0	62	9	0	7	0	16	270
07:30	9	187	23	1	220	1	1	2	0	4	5	59	3	0	67	20	2	7	0	29	320
07:45	12	185	32	0	229	1	0	4	0	5	8	84	2	0	94	8	1	10	0	19	347
Total	53	641	91	1	786	2	1	12	0	15	19	237	13	0	269	43	6	24	0	73	1143
08:00	36	145	39	0	220	0	0	3	0	3	5	58	9	0	72	15	1	6	0	22	317
08:15	14	112	38	0	164	0	1	6	0	7	2	63	3	0	68	13	1	11	0	25	264
08:30	21	107	34	0	162	1	1	8	0	10	8	60	8	0	76	19	1	7	0	27	275
08:45	13	114	43	0	170	5	1	6	0	12	6	91	2	0	99	28	1	14	0	43	324
Total	84	478	154	0	716	6	3	23	0	32	21	272	22	0	315	75	4	38	0	117	1180
11:00	10	81	61	0	152	4	3	12	0	19	14	75	1	0	90	46	0	17	0	63	324
11:15	9	76	63	0	148	0	2	19	0	21	21	101	3	0	125	43	4	13	0	60	354
11:30	18	78	66	0	162	4	3	11	0	18	41	116	3	0	160	40	4	20	0	64	404
11:45	17	90	99	0	206	6	1	7	0	14	24	76	3	0	103	69	4	15	0	88	411
Total	54	325	289	0	668	14	9	49	0	72	100	368	10	0	478	198	12	65	0	275	1493
12:00	7	102	110	0	219	6	5	13	0	24	27	119	5	0	151	67	4	25	0	96	490
12:15	24	80	86	0	190	4	1	5	0	10	23	112	3	0	138	92	2	33	0	127	465
12:30	13	107	85	0	205	4	1	6	0	11	20	110	8	0	138	79	3	36	0	118	472
12:45	18	118	76	0	212	2	1	11	0	14	16	94	6	0	116	88	3	21	0	112	454
Total	62	407	357	0	826	16	8	35	0	59	86	435	22	0	543	326	12	115	0	453	1881
15:00	14	57	61	0	132	3	0	8	0	11	14	122	5	0	141	57	0	26	1	84	368
15:15	7	84	67	0	158	5	0	15	0	20	8	114	2	0	124	64	2	14	0	80	382
15:30	10	116	45	0	171	0	1	30	0	31	14	191	2	0	207	60	1	12	0	73	482
15:45	8	66	54	0	128	3	1	15	0	19	22	159	4	0	185	41	1	24	0	66	398
Total	39	323	227	0	589	11	2	68	0	81	58	586	13	0	657	222	4	76	1	303	1630
16:00	5	67	39	0	111	2	0	21	0	23	11	163	2	0	176	45	2	13	0	60	370
16:15	11	87	50	0	148	1	1	15	0	17	13	167	3	0	183	49	2	17	0	68	416
16:30	7	103	37	0	147	7	2	21	0	30	13	249	1	0	263	47	2	21	0	70	510
16:45	4	97	48	0	149	2	1	9	0	12	21	205	0	0	226	45	0	16	0	61	448
Total	27	354	174	0	555	12	4	66	0	82	58	784	6	0	848	186	6	67	0	259	1744
17:00	6	109	50	0	165	9	2	18	0	29	13	227	4	0	244	43	1	20	0	64	502
17:15	1	94	59	0	154	6	0	11	0	17	26	238	2	0	266	61	2	20	0	83	520
17:30	2	108	68	0	178	1	1	13	0	15	19	222	2	0	243	61	1	16	0	78	514
17:45	2	116	71	0	189	1	0	9	0	10	24	211	0	0	235	48	1	16	0	65	499
Total	11	427	248	0	686	17	3	51	0	71	82	898	8	0	988	213	5	72	0	290	2035
Grand Total	396	3216	1598	1	5211	84	31	312	1	428	433	3679	104	0	4216	1285	51	466	1	1803	11658
Apprch %	7.6	61.7	30.7	0		19.6	7.2	72.9	0.2		10.3	87.3	2.5	0		71.3	2.8	25.8	0.1		
Total %	3.4	27.6	13.7	0	44.7	0.7	0.3	2.7	0	3.7	3.7	31.6	0.9	0	36.2	11	0.4	4	0	15.5	



MINNESOTA DEPT OF TRANSPORTATION

TRAFFIC DATA COLLECTION - METRO

File Name : VICKSBURG LANE N @ 32nd AV N 2006
 Site Code : 07260812
 Start Date : 7/26/2006
 Page No : 2

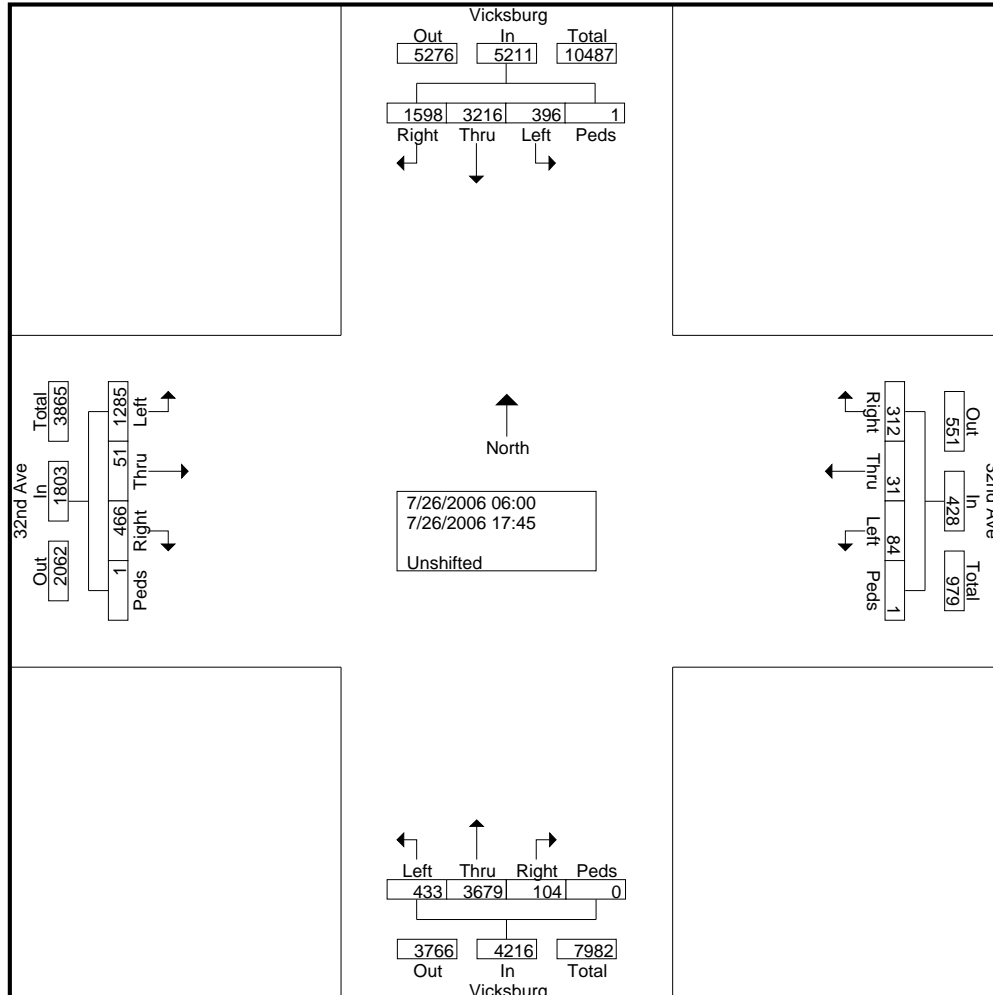



MINNESOTA DEPT OF TRANSPORTATION

TRAFFIC DATA COLLECTION - METRO

File Name : VICKSBURG LANE N @ 32nd AV N 2006
 Site Code : 07260812
 Start Date : 7/26/2006
 Page No : 3

Start Time	Vicksburg Southbound					32nd Ave Westbound					Vicksburg Northbound					32nd Ave Eastbound					Int. Total
	Left	Thru	Right	Peds	App. Total	Left	Thru	Right	Peds	App. Total	Left	Thru	Right	Peds	App. Total	Left	Thru	Right	Peds	App. Total	
Peak Hour Analysis From 06:00 to 09:45 - Peak 1 of 1																					
Peak Hour for Entire Intersection Begins at 07:15																					
07:15	12	155	22	0	189	0	0	3	0	3	4	53	5	0	62	9	0	7	0	16	270
07:30	9	187	23	1	220	1	1	2	0	4	5	59	3	0	67	20	2	7	0	29	320
07:45	12	185	32	0	229	1	0	4	0	5	8	84	2	0	94	8	1	10	0	19	347
08:00	36	145	39	0	220	0	0	3	0	3	5	58	9	0	72	15	1	6	0	22	317
Total Volume	69	672	116	1	858	2	1	12	0	15	22	254	19	0	295	52	4	30	0	86	1254
% App. Total	8	78.3	13.5	0.1		13.3	6.7	80	0		7.5	86.1	6.4	0		60.5	4.7	34.9	0		
PHF	.479	.898	.744	.250	.937	.500	.250	.750	.000	.750	.688	.756	.528	.000	.785	.650	.500	.750	.000	.741	.903

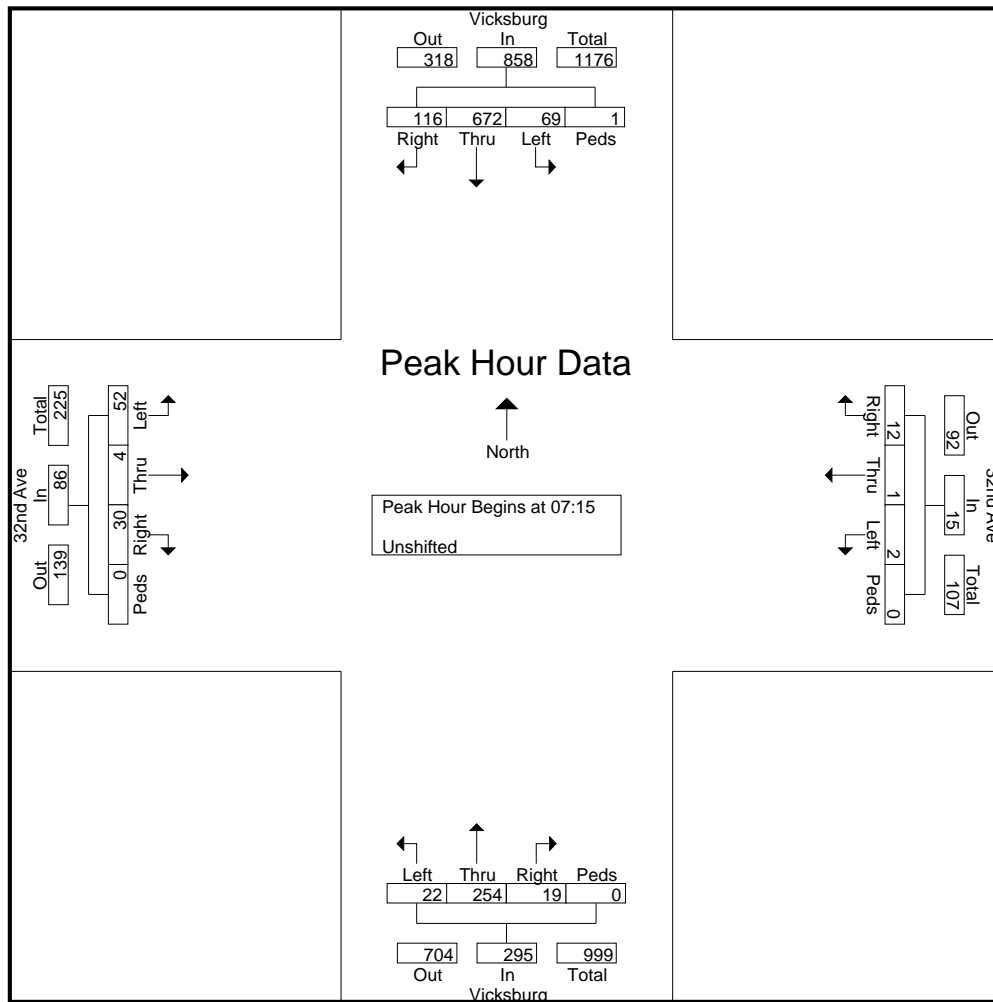



MINNESOTA DEPT OF TRANSPORTATION

TRAFFIC DATA COLLECTION - METRO

File Name : VICKSBURG LANE N @ 32nd AV N 2006
 Site Code : 07260812
 Start Date : 7/26/2006
 Page No : 4

Start Time	Vicksburg Southbound					32nd Ave Westbound					Vicksburg Northbound					32nd Ave Eastbound					Int. Total
	Left	Thru	Right	Peds	App. Total	Left	Thru	Right	Peds	App. Total	Left	Thru	Right	Peds	App. Total	Left	Thru	Right	Peds	App. Total	
12:00	7	102	110	0	219	6	5	13	0	24	27	119	5	0	151	67	4	25	0	96	490
12:15	24	80	86	0	190	4	1	5	0	10	23	112	3	0	138	92	2	33	0	127	465
12:30	13	107	85	0	205	4	1	6	0	11	20	110	8	0	138	79	3	36	0	118	472
12:45	18	118	76	0	212	2	1	11	0	14	16	94	6	0	116	88	3	21	0	112	454
Total Volume	62	407	357	0	826	16	8	35	0	59	86	435	22	0	543	326	12	115	0	453	1881
% App. Total	7.5	49.3	43.2	0		27.1	13.6	59.3	0		15.8	80.1	4.1	0		72	2.6	25.4	0		
PHF	.646	.862	.811	.000	.943	.667	.400	.673	.000	.615	.796	.914	.688	.000	.899	.886	.750	.799	.000	.892	.960

Peak Hour Analysis From 10:00 to 13:45 - Peak 1 of 1
 Peak Hour for Entire Intersection Begins at 12:00

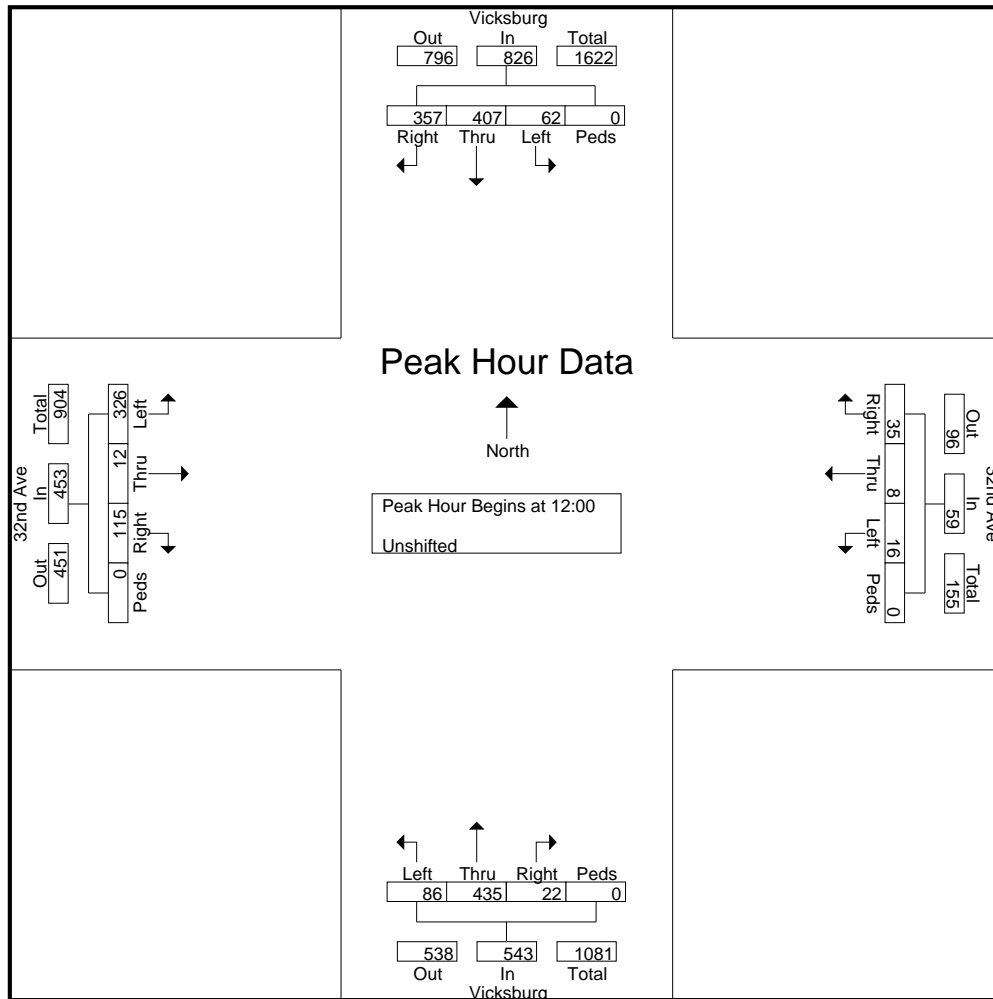



MINNESOTA DEPT OF TRANSPORTATION

TRAFFIC DATA COLLECTION - METRO

File Name : VICKSBURG LANE N @ 32nd AV N 2006
 Site Code : 07260812
 Start Date : 7/26/2006
 Page No : 5

Start Time	Vicksburg Southbound					32nd Ave Westbound					Vicksburg Northbound					32nd Ave Eastbound					Int. Total
	Left	Thru	Right	Peds	App. Total	Left	Thru	Right	Peds	App. Total	Left	Thru	Right	Peds	App. Total	Left	Thru	Right	Peds	App. Total	
17:00	6	109	50	0	165	9	2	18	0	29	13	227	4	0	244	43	1	20	0	64	502
17:15	1	94	59	0	154	6	0	11	0	17	26	238	2	0	266	61	2	20	0	83	520
17:30	2	108	68	0	178	1	1	13	0	15	19	222	2	0	243	61	1	16	0	78	514
17:45	2	116	71	0	189	1	0	9	0	10	24	211	0	0	235	48	1	16	0	65	499
Total Volume	11	427	248	0	686	17	3	51	0	71	82	898	8	0	988	213	5	72	0	290	2035
% App. Total	1.6	62.2	36.2	0		23.9	4.2	71.8	0		8.3	90.9	0.8	0		73.4	1.7	24.8	0		
PHF	.458	.920	.873	.000	.907	.472	.375	.708	.000	.612	.788	.943	.500	.000	.929	.873	.625	.900	.000	.873	.978

Peak Hour Analysis From 14:00 to 17:45 - Peak 1 of 1
 Peak Hour for Entire Intersection Begins at 17:00

