

Alliant Engineering Inc Minneapolis, MN 55415

Fernbrook Lane at 27th Ave N
Ref.Pt.: S of TH-55
Alliant Engineering Inc
TURN MOVEMENT COUNTS

File Name : 46_Fernbrook Ln at 27th Ave_012511
Site Code : 00000046
Start Date : 1/25/2011
Page No : 1

Groups Printed- Unshifted - Bank 1

Start Time	Fernbrook Lane Southbound				commercial entrance Westbound				Fernbrook Lane Northbound				27th Ave N Eastbound				Int. Total
	Left	Thru	Rght	Peds	Left	Thru	Rght	Peds	Left	Thru	Rght	Peds	Left	Thru	Rght	Peds	
06:00	0	21	17	0	0	0	0	0	9	9	0	0	22	1	2	1	82
06:15	3	30	32	0	0	0	0	0	11	6	0	0	5	0	0	0	87
06:30	3	51	32	0	0	0	0	0	9	11	0	0	7	0	2	0	115
06:45	4	49	34	0	0	0	0	0	24	7	0	0	8	0	7	1	134
Total	10	151	115	0	0	0	0	0	53	33	0	0	42	1	11	2	418
07:00	9	57	30	0	1	0	0	0	17	18	0	0	6	0	3	0	141
07:15	5	54	42	0	0	0	0	0	25	27	0	0	7	0	3	0	163
07:30	2	107	46	0	0	0	0	0	20	27	0	0	16	0	6	1	225
07:45	3	96	54	0	0	0	0	0	34	30	0	0	13	0	13	0	243
Total	19	314	172	0	1	0	0	0	96	102	0	0	42	0	25	1	772
08:00	2	78	52	0	0	0	0	0	24	29	1	0	14	0	10	0	210
08:15	10	66	52	0	0	0	1	0	14	23	1	0	7	0	2	0	176
08:30	3	59	38	0	1	0	0	0	13	23	0	0	11	0	1	0	149
08:45	2	41	31	0	0	0	0	0	13	27	0	0	16	0	4	0	134
Total	17	244	173	0	1	0	1	0	64	102	2	0	48	0	17	0	669
09:00	5	38	29	0	0	0	0	0	5	26	0	0	7	0	6	1	117
09:15	2	39	8	0	0	0	0	0	11	27	0	0	17	0	6	0	110
*** BREAK ***																	
Total	7	77	37	0	0	0	0	0	16	53	0	0	24	0	12	1	227
*** BREAK ***																	
10:30	4	39	16	0	0	0	0	0	6	24	0	0	21	0	6	0	116
10:45	5	32	16	0	0	0	1	0	7	33	0	0	17	0	2	0	113
Total	9	71	32	0	0	0	1	0	13	57	0	0	38	0	8	0	229
11:00	9	31	13	0	0	0	1	0	10	43	0	0	28	0	7	0	142
11:15	8	39	18	0	0	0	0	0	16	46	1	0	43	0	5	0	176
11:30	14	53	18	0	0	0	0	0	23	56	0	0	50	0	12	0	226
11:45	16	51	17	0	0	0	0	0	23	47	0	0	35	0	10	3	202
Total	47	174	66	0	0	0	1	0	72	192	1	0	156	0	34	3	746
12:00	14	60	23	0	0	0	0	0	30	60	0	0	56	1	11	0	255
12:15	27	64	20	0	0	0	0	0	17	56	0	0	51	0	11	0	246
12:30	21	76	22	0	0	0	1	0	16	44	0	0	44	0	10	3	237
12:45	19	86	32	0	0	0	0	0	10	38	0	0	39	0	9	0	233
Total	81	286	97	0	0	0	1	0	73	198	0	0	190	1	41	3	971
13:00	13	68	19	0	0	0	0	0	10	52	0	0	46	0	10	0	218
13:15	18	69	22	0	0	0	0	0	20	56	0	0	44	0	8	0	237
*** BREAK ***																	
Total	31	137	41	0	0	0	0	0	30	108	0	0	90	0	18	0	455
*** BREAK ***																	
14:30	8	51	15	0	0	0	0	0	12	40	0	0	39	1	16	0	182
14:45	8	49	14	0	0	0	1	0	12	26	0	0	38	0	6	0	154
Total	16	100	29	0	0	0	1	0	24	66	0	0	77	1	22	0	336
15:00	12	36	9	0	1	0	0	0	6	73	0	0	51	0	17	0	205
15:15	9	39	17	0	0	0	0	0	10	54	0	0	26	0	10	0	165
15:30	8	29	7	0	0	0	0	0	8	96	0	0	67	0	13	0	228
15:45	15	37	6	0	1	0	1	0	10	64	0	0	38	0	14	0	186
Total	44	141	39	0	2	0	1	0	34	287	0	0	182	0	54	0	784

Alliant Engineering Inc Minneapolis, MN 55415

Fernbrook Lane at 27th Ave N
Ref.Pt.: S of TH-55
Alliant Engineering Inc
TURN MOVEMENT COUNTS

File Name : 46_Fernbrook Ln at 27th Ave_012511
Site Code : 00000046
Start Date : 1/25/2011
Page No : 2

Groups Printed- Unshifted - Bank 1

Start Time	Fernbrook Lane Southbound				commercial entrance Westbound				Fernbrook Lane Northbound				27th Ave N Eastbound				Int. Total
	Left	Thru	Rght	Peds	Left	Thru	Rght	Peds	Left	Thru	Rght	Peds	Left	Thru	Rght	Peds	
16:00	13	26	6	0	0	0	0	0	15	118	0	0	53	0	26	0	257
16:15	43	30	6	0	0	0	0	0	11	122	0	0	64	0	10	0	286
16:30	13	17	7	0	0	0	1	0	9	124	0	0	88	0	23	0	282
16:45	8	23	4	0	0	0	0	0	7	98	0	0	58	0	17	0	215
Total	77	96	23	0	0	0	1	0	42	462	0	0	263	0	76	0	1040
17:00	18	23	6	0	1	0	0	0	14	129	0	0	91	0	18	0	300
17:15	24	20	7	0	0	0	1	0	5	117	0	0	43	0	11	0	228
17:30	20	25	3	0	0	0	0	0	9	66	0	0	45	0	8	0	176
17:45	17	17	3	0	0	0	0	0	4	60	0	0	29	0	4	0	134
Total	79	85	19	0	1	0	1	0	32	372	0	0	208	0	41	0	838
Grand Total	437	1876	843	0	5	0	8	0	549	2032	3	0	1360	3	359	10	7485
Apprch %	13.8	59.4	26.7	0	38.5	0	61.5	0	21.2	78.6	0.1	0	78.5	0.2	20.7	0.6	
Total %	5.8	25.1	11.3	0	0.1	0	0.1	0	7.3	27.1	0	0	18.2	0	4.8	0.1	
Unshifted	436	1863	834	0	4	0	7	0	528	2000	2	0	1323	3	343	10	7353
% Unshifted	99.8	99.3	98.9	0	80	0	87.5	0	96.2	98.4	66.7	0	97.3	100	95.5	100	98.2
Bank 1	1	13	9	0	1	0	1	0	21	32	1	0	37	0	16	0	132
% Bank 1	0.2	0.7	1.1	0	20	0	12.5	0	3.8	1.6	33.3	0	2.7	0	4.5	0	1.8

Alliant Engineering Inc Minneapolis, MN 55415

Fernbrook Lane at 27th Ave N
Ref.Pt.: S of TH-55
Alliant Engineering Inc
TURN MOVEMENT COUNTS

File Name : 46_Fernbrook Ln at 27th Ave_012511
Site Code : 00000046
Start Date : 1/25/2011
Page No : 3

Start Time	Fernbrook Lane Southbound					commercial entrance Westbound					Fernbrook Lane Northbound					27th Ave N Eastbound					Int. Total
	Left	Thru	Rght	Peds	App. Total	Left	Thru	Rght	Peds	App. Total	Left	Thru	Rght	Peds	App. Total	Left	Thru	Rght	Peds	App. Total	
Peak Hour Analysis From 06:00 to 09:15 - Peak 1 of 1																					
Peak Hour for Entire Intersection Begins at 07:30																					
07:30	2	107	46	0	155	0	0	0	0	0	20	27	0	0	47	16	0	6	1	23	225
07:45	3	96	54	0	153	0	0	0	0	0	34	30	0	0	64	13	0	13	0	26	243
08:00	2	78	52	0	132	0	0	0	0	0	24	29	1	0	54	14	0	10	0	24	210
08:15	10	66	52	0	128	0	0	1	0	1	14	23	1	0	38	7	0	2	0	9	176
Total Volume	17	347	204	0	568	0	0	1	0	1	92	109	2	0	203	50	0	31	1	82	854
% App. Total	3	61.1	35.9	0		0	0	100	0		45.3	53.7	1	0		61	0	37.8	1.2		
PHF	.425	.811	.944	.000	.916	.000	.000	.250	.000	.250	.676	.908	.500	.000	.793	.781	.000	.596	.250	.788	.879

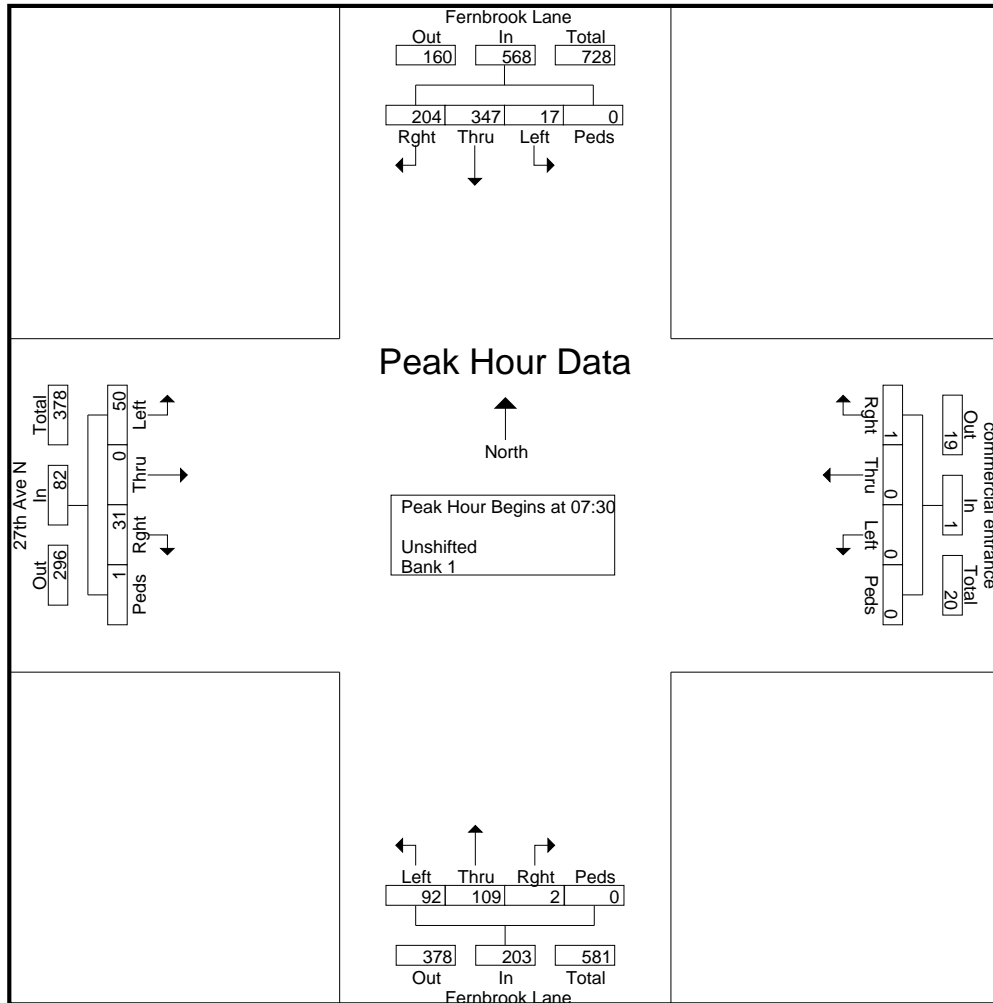

Alliant Engineering Inc Minneapolis, MN 55415

Fernbrook Lane at 27th Ave N
Ref.Pt.: S of TH-55
Alliant Engineering Inc
TURN MOVEMENT COUNTS

File Name : 46_Fernbrook Ln at 27th Ave_012511
Site Code : 00000046
Start Date : 1/25/2011
Page No : 4

Start Time	Fernbrook Lane Southbound					commercial entrance Westbound					Fernbrook Lane Northbound					27th Ave N Eastbound					Int. Total
	Left	Thru	Rght	Peds	App. Total	Left	Thru	Rght	Peds	App. Total	Left	Thru	Rght	Peds	App. Total	Left	Thru	Rght	Peds	App. Total	
Peak Hour Analysis From 14:30 to 17:45 - Peak 1 of 1																					
Peak Hour for Entire Intersection Begins at 16:15																					
16:15	43	30	6	0	79	0	0	0	0	0	11	122	0	0	133	64	0	10	0	74	286
16:30	13	17	7	0	37	0	0	1	0	1	9	124	0	0	133	88	0	23	0	111	282
16:45	8	23	4	0	35	0	0	0	0	0	7	98	0	0	105	58	0	17	0	75	215
17:00	18	23	6	0	47	1	0	0	0	1	14	129	0	0	143	91	0	18	0	109	300
Total Volume	82	93	23	0	198	1	0	1	0	2	41	473	0	0	514	301	0	68	0	369	1083
% App. Total	41.4	47	11.6	0		50	0	50	0		8	92	0	0		81.6	0	18.4	0		
PHF	.477	.775	.821	.000	.627	.250	.000	.250	.000	.500	.732	.917	.000	.000	.899	.827	.000	.739	.000	.831	.903

