

Alliant Engineering

Minneapolis, MN 55415

--TRAFFIC DATA --

TH-55 at Argenta Trail

File Name : 118 - TH 55 & Argenta Trail

Site Code : 118

BY : Alliant Eng.

Start Date : 11/18/2014

TURN MOVEMENT COUNT

Page No : 1

Groups Printed- Cars - Trucks

| Start Time | Argenta Trail Southbound | | | | TH 55 Westbound | | | | Argenta Trail Northbound | | | | TH 55 Eastbound | | | | Int. Total |
|---------------|--------------------------|------|------|-------|-----------------|------|------|-------|--------------------------|------|------|-------|-----------------|------|------|-------|------------|
| | Left | Thru | Rght | Bikes | Left | Thru | Rght | Bikes | Left | Thru | Rght | Bikes | Left | Thru | Rght | Bikes | |
| 06:00 | 1 | 32 | 0 | 0 | 38 | 121 | 1 | 0 | 12 | 8 | 12 | 0 | 0 | 55 | 1 | 0 | 281 |
| 06:15 | 0 | 42 | 0 | 0 | 53 | 179 | 5 | 0 | 10 | 13 | 26 | 0 | 1 | 71 | 1 | 0 | 401 |
| 06:30 | 0 | 21 | 1 | 0 | 100 | 189 | 2 | 0 | 14 | 24 | 34 | 0 | 0 | 76 | 1 | 0 | 462 |
| 06:45 | 0 | 42 | 2 | 0 | 111 | 200 | 3 | 0 | 11 | 27 | 29 | 0 | 2 | 68 | 5 | 0 | 500 |
| Total | 1 | 137 | 3 | 0 | 302 | 689 | 11 | 0 | 47 | 72 | 101 | 0 | 3 | 270 | 8 | 0 | 1644 |
| 07:00 | 1 | 41 | 1 | 0 | 94 | 231 | 12 | 0 | 21 | 42 | 40 | 0 | 0 | 79 | 2 | 0 | 564 |
| 07:15 | 3 | 39 | 4 | 0 | 112 | 216 | 11 | 0 | 13 | 44 | 39 | 0 | 1 | 73 | 5 | 0 | 560 |
| 07:30 | 0 | 64 | 0 | 0 | 156 | 240 | 22 | 0 | 11 | 38 | 48 | 0 | 0 | 83 | 9 | 0 | 671 |
| 07:45 | 1 | 63 | 3 | 0 | 158 | 213 | 16 | 0 | 14 | 38 | 46 | 0 | 0 | 86 | 4 | 0 | 642 |
| Total | 5 | 207 | 8 | 0 | 520 | 900 | 61 | 0 | 59 | 162 | 173 | 0 | 1 | 321 | 20 | 0 | 2437 |
| 08:00 | 5 | 58 | 3 | 0 | 108 | 178 | 13 | 0 | 9 | 41 | 39 | 0 | 0 | 73 | 3 | 0 | 530 |
| 08:15 | 1 | 39 | 4 | 0 | 99 | 182 | 9 | 0 | 8 | 31 | 29 | 0 | 0 | 80 | 3 | 0 | 485 |
| 08:30 | 5 | 43 | 1 | 0 | 72 | 147 | 4 | 0 | 9 | 24 | 34 | 0 | 2 | 82 | 7 | 0 | 430 |
| 08:45 | 0 | 26 | 3 | 0 | 55 | 124 | 2 | 0 | 9 | 32 | 47 | 0 | 1 | 86 | 6 | 0 | 391 |
| Total | 11 | 166 | 11 | 0 | 334 | 631 | 28 | 0 | 35 | 128 | 149 | 0 | 3 | 321 | 19 | 0 | 1836 |
| 09:00 | 1 | 18 | 1 | 0 | 54 | 117 | 2 | 0 | 8 | 40 | 50 | 0 | 1 | 74 | 4 | 0 | 370 |
| 09:15 | 1 | 24 | 1 | 0 | 39 | 124 | 3 | 0 | 10 | 33 | 36 | 0 | 0 | 98 | 3 | 0 | 372 |
| *** BREAK *** | | | | | | | | | | | | | | | | | |
| Total | 2 | 42 | 2 | 0 | 93 | 241 | 5 | 0 | 18 | 73 | 86 | 0 | 1 | 172 | 7 | 0 | 742 |
| *** BREAK *** | | | | | | | | | | | | | | | | | |
| 10:30 | 1 | 13 | 3 | 0 | 25 | 107 | 0 | 0 | 6 | 20 | 30 | 0 | 0 | 64 | 5 | 0 | 274 |
| 10:45 | 1 | 11 | 4 | 0 | 39 | 99 | 3 | 0 | 7 | 14 | 35 | 0 | 0 | 64 | 9 | 0 | 286 |
| Total | 2 | 24 | 7 | 0 | 64 | 206 | 3 | 0 | 13 | 34 | 65 | 0 | 0 | 128 | 14 | 0 | 560 |
| 11:00 | 2 | 15 | 2 | 0 | 35 | 79 | 3 | 0 | 8 | 15 | 26 | 0 | 0 | 70 | 1 | 0 | 256 |
| 11:15 | 2 | 18 | 2 | 0 | 30 | 100 | 3 | 0 | 7 | 9 | 26 | 0 | 1 | 91 | 1 | 0 | 290 |
| 11:30 | 3 | 14 | 1 | 0 | 29 | 102 | 2 | 0 | 4 | 11 | 30 | 0 | 1 | 68 | 2 | 0 | 267 |
| 11:45 | 1 | 17 | 1 | 0 | 32 | 112 | 1 | 0 | 6 | 13 | 36 | 0 | 1 | 91 | 7 | 0 | 318 |
| Total | 8 | 64 | 6 | 0 | 126 | 393 | 9 | 0 | 25 | 48 | 118 | 0 | 3 | 320 | 11 | 0 | 1131 |
| 12:00 | 0 | 26 | 5 | 0 | 50 | 106 | 2 | 0 | 2 | 20 | 35 | 0 | 0 | 88 | 3 | 0 | 337 |
| 12:15 | 1 | 12 | 3 | 0 | 40 | 113 | 0 | 0 | 6 | 13 | 36 | 0 | 0 | 79 | 6 | 0 | 309 |
| 12:30 | 2 | 15 | 1 | 0 | 41 | 121 | 5 | 0 | 3 | 16 | 26 | 0 | 1 | 86 | 13 | 0 | 330 |
| 12:45 | 1 | 12 | 2 | 0 | 29 | 90 | 1 | 0 | 2 | 18 | 33 | 0 | 0 | 92 | 7 | 0 | 287 |
| Total | 4 | 65 | 11 | 0 | 160 | 430 | 8 | 0 | 13 | 67 | 130 | 0 | 1 | 345 | 29 | 0 | 1263 |
| 13:00 | 4 | 21 | 0 | 0 | 30 | 119 | 3 | 0 | 2 | 7 | 38 | 1 | 0 | 86 | 4 | 0 | 315 |
| 13:15 | 1 | 17 | 0 | 0 | 24 | 99 | 3 | 0 | 6 | 15 | 33 | 0 | 0 | 85 | 5 | 0 | 288 |
| *** BREAK *** | | | | | | | | | | | | | | | | | |
| Total | 5 | 38 | 0 | 0 | 54 | 218 | 6 | 0 | 8 | 22 | 71 | 1 | 0 | 171 | 9 | 0 | 603 |
| *** BREAK *** | | | | | | | | | | | | | | | | | |
| 14:30 | 4 | 15 | 0 | 0 | 31 | 123 | 2 | 0 | 4 | 39 | 69 | 0 | 0 | 131 | 6 | 0 | 424 |
| 14:45 | 4 | 26 | 1 | 0 | 47 | 107 | 2 | 0 | 2 | 31 | 64 | 0 | 1 | 133 | 8 | 0 | 426 |
| Total | 8 | 41 | 1 | 0 | 78 | 230 | 4 | 0 | 6 | 70 | 133 | 0 | 1 | 264 | 14 | 0 | 850 |
| 15:00 | 7 | 30 | 1 | 0 | 31 | 103 | 2 | 0 | 4 | 46 | 73 | 0 | 0 | 137 | 7 | 0 | 441 |
| 15:15 | 6 | 22 | 0 | 0 | 33 | 104 | 1 | 0 | 3 | 33 | 73 | 0 | 0 | 145 | 14 | 0 | 434 |
| 15:30 | 5 | 35 | 2 | 0 | 56 | 112 | 3 | 0 | 6 | 27 | 92 | 0 | 0 | 171 | 8 | 0 | 517 |
| 15:45 | 6 | 33 | 1 | 1 | 47 | 109 | 1 | 0 | 3 | 37 | 82 | 0 | 1 | 185 | 13 | 0 | 519 |
| Total | 24 | 120 | 4 | 1 | 167 | 428 | 7 | 0 | 16 | 143 | 320 | 0 | 1 | 638 | 42 | 0 | 1911 |
| 16:00 | 15 | 28 | 1 | 0 | 43 | 112 | 1 | 0 | 5 | 50 | 106 | 0 | 0 | 179 | 10 | 0 | 550 |
| 16:15 | 5 | 37 | 2 | 0 | 40 | 94 | 0 | 0 | 9 | 55 | 138 | 0 | 0 | 198 | 14 | 0 | 592 |
| 16:30 | 14 | 42 | 1 | 0 | 53 | 135 | 1 | 0 | 3 | 44 | 134 | 0 | 0 | 298 | 14 | 0 | 739 |

Alliant Engineering

Minneapolis, MN 55415

--TRAFFIC DATA --

TH-55 at Argenta Trail

File Name : 118 - TH 55 & Argenta Trail

Site Code : 118

BY : Alliant Eng.

Start Date : 11/18/2014

TURN MOVEMENT COUNT

Page No : 2

Groups Printed- Cars - Trucks

| Start Time | Argenta Trail Southbound | | | | TH 55 Westbound | | | | Argenta Trail Northbound | | | | TH 55 Eastbound | | | | Int. Total |
|-------------|--------------------------|------|------|-------|-----------------|------|------|-------|--------------------------|------|------|-------|-----------------|------|------|-------|------------|
| | Left | Thru | Rght | Bikes | Left | Thru | Rght | Bikes | Left | Thru | Rght | Bikes | Left | Thru | Rght | Bikes | |
| 16:45 | 11 | 38 | 3 | 0 | 76 | 125 | 4 | 0 | 6 | 33 | 134 | 0 | 0 | 216 | 11 | 0 | 657 |
| Total | 45 | 145 | 7 | 0 | 212 | 466 | 6 | 0 | 23 | 182 | 512 | 0 | 0 | 891 | 49 | 0 | 2538 |
| 17:00 | 17 | 64 | 2 | 0 | 62 | 119 | 3 | 0 | 4 | 47 | 134 | 0 | 0 | 243 | 8 | 0 | 703 |
| 17:15 | 4 | 51 | 2 | 0 | 62 | 138 | 1 | 0 | 6 | 38 | 104 | 0 | 0 | 242 | 11 | 0 | 659 |
| 17:30 | 6 | 34 | 4 | 0 | 42 | 141 | 1 | 0 | 3 | 43 | 121 | 0 | 0 | 197 | 15 | 0 | 607 |
| 17:45 | 3 | 30 | 0 | 0 | 53 | 131 | 4 | 0 | 6 | 25 | 78 | 0 | 0 | 194 | 16 | 0 | 540 |
| Total | 30 | 179 | 8 | 0 | 219 | 529 | 9 | 0 | 19 | 153 | 437 | 0 | 0 | 876 | 50 | 0 | 2509 |
| Grand Total | 145 | 1228 | 68 | 1 | 2329 | 5361 | 157 | 0 | 282 | 1154 | 2295 | 1 | 14 | 4717 | 272 | 0 | 18024 |
| Apprch % | 10.1 | 85.2 | 4.7 | 0.1 | 29.7 | 68.3 | 2 | 0 | 7.6 | 30.9 | 61.5 | 0 | 0.3 | 94.3 | 5.4 | 0 | |
| Total % | 0.8 | 6.8 | 0.4 | 0 | 12.9 | 29.7 | 0.9 | 0 | 1.6 | 6.4 | 12.7 | 0 | 0.1 | 26.2 | 1.5 | 0 | |
| Cars | 144 | 1215 | 65 | 0 | 2219 | 4965 | 155 | 0 | 267 | 1113 | 2193 | 0 | 9 | 4356 | 258 | 0 | 16959 |
| % Cars | 99.3 | 98.9 | 95.6 | 0 | 95.3 | 92.6 | 98.7 | 0 | 94.7 | 96.4 | 95.6 | 0 | 64.3 | 92.3 | 94.9 | 0 | 94.1 |
| Trucks | 1 | 13 | 3 | 1 | 110 | 396 | 2 | 0 | 15 | 41 | 102 | 1 | 5 | 361 | 14 | 0 | 1065 |
| % Trucks | 0.7 | 1.1 | 4.4 | 100 | 4.7 | 7.4 | 1.3 | 0 | 5.3 | 3.6 | 4.4 | 100 | 35.7 | 7.7 | 5.1 | 0 | 5.9 |

Alliant Engineering

Minneapolis, MN 55415

--TRAFFIC DATA --

TH-55 at Argenta Trail

File Name : 118 - TH 55 & Argenta Trail

BY : Alliant Eng.

Site Code : 118

TURN MOVEMENT COUNT

Start Date : 11/18/2014

Page No : 3

| Start Time | Argenta Trail Southbound | | | | | TH 55 Westbound | | | | | Argenta Trail Northbound | | | | | TH 55 Eastbound | | | | | Int. Total |
|--|--------------------------|------|-------|-------|------------|-----------------|------|-------|-------|------------|--------------------------|------|-------|-------|------------|-----------------|------|-------|-------|------------|------------|
| | Left | Thru | Right | Bikes | App. Total | Left | Thru | Right | Bikes | App. Total | Left | Thru | Right | Bikes | App. Total | Left | Thru | Right | Bikes | App. Total | |
| Peak Hour Analysis From 06:00 to 11:45 - Peak 1 of 1 | | | | | | | | | | | | | | | | | | | | | |
| Peak Hour for Entire Intersection Begins at 07:00 | | | | | | | | | | | | | | | | | | | | | |
| 07:00 | 1 | 41 | 1 | 0 | 43 | 94 | 231 | 12 | 0 | 337 | 21 | 42 | 40 | 0 | 103 | 0 | 79 | 2 | 0 | 81 | 564 |
| 07:15 | 3 | 39 | 4 | 0 | 46 | 112 | 216 | 11 | 0 | 339 | 13 | 44 | 39 | 0 | 96 | 1 | 73 | 5 | 0 | 79 | 560 |
| 07:30 | 0 | 64 | 0 | 0 | 64 | 156 | 240 | 22 | 0 | 418 | 11 | 38 | 48 | 0 | 97 | 0 | 83 | 9 | 0 | 92 | 671 |
| 07:45 | 1 | 63 | 3 | 0 | 67 | 158 | 213 | 16 | 0 | 387 | 14 | 38 | 46 | 0 | 98 | 0 | 86 | 4 | 0 | 90 | 642 |
| Total Volume | 5 | 207 | 8 | 0 | 220 | 520 | 900 | 61 | 0 | 1481 | 59 | 162 | 173 | 0 | 394 | 1 | 321 | 20 | 0 | 342 | 2437 |
| % App. Total | 2.3 | 94.1 | 3.6 | 0 | | 35.1 | 60.8 | 4.1 | 0 | | 15 | 41.1 | 43.9 | 0 | | 0.3 | 93.9 | 5.8 | 0 | | |
| PHF | .417 | .809 | .500 | .000 | .821 | .823 | .938 | .693 | .000 | .886 | .702 | .920 | .901 | .000 | .956 | .250 | .933 | .556 | .000 | .929 | .908 |

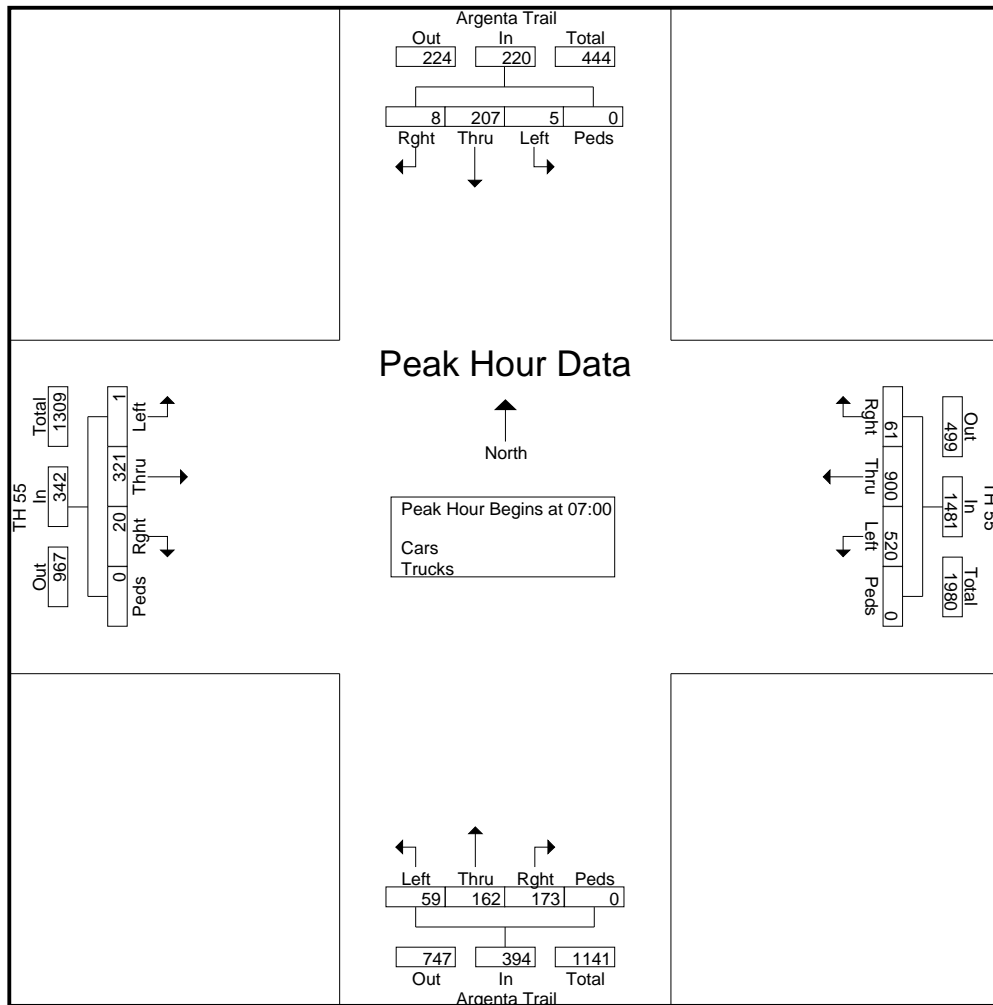

Alliant Engineering

Minneapolis, MN 55415

--TRAFFIC DATA --

TH-55 at Argenta Trail

File Name : 118 - TH 55 & Argenta Trail

Site Code : 118

BY : Alliant Eng.

Start Date : 11/18/2014

TURN MOVEMENT COUNT

Page No : 4

| Start Time | Argenta Trail Southbound | | | | | TH 55 Westbound | | | | | Argenta Trail Northbound | | | | | TH 55 Eastbound | | | | | Int. Total |
|--|--------------------------|------|------|-------|------------|-----------------|------|------|-------|------------|--------------------------|------|------|-------|------------|-----------------|------|------|-------|------------|------------|
| | Left | Thru | Rght | Bikes | App. Total | Left | Thru | Rght | Bikes | App. Total | Left | Thru | Rght | Bikes | App. Total | Left | Thru | Rght | Bikes | App. Total | |
| Peak Hour Analysis From 12:00 to 17:45 - Peak 1 of 1 | | | | | | | | | | | | | | | | | | | | | |
| Peak Hour for Entire Intersection Begins at 16:30 | | | | | | | | | | | | | | | | | | | | | |
| 16:30 | 14 | 42 | 1 | 0 | 57 | 53 | 135 | 1 | 0 | 189 | 3 | 44 | 134 | 0 | 181 | 0 | 298 | 14 | 0 | 312 | 739 |
| 16:45 | 11 | 38 | 3 | 0 | 52 | 76 | 125 | 4 | 0 | 205 | 6 | 33 | 134 | 0 | 173 | 0 | 216 | 11 | 0 | 227 | 657 |
| 17:00 | 17 | 64 | 2 | 0 | 83 | 62 | 119 | 3 | 0 | 184 | 4 | 47 | 134 | 0 | 185 | 0 | 243 | 8 | 0 | 251 | 703 |
| 17:15 | 4 | 51 | 2 | 0 | 57 | 62 | 138 | 1 | 0 | 201 | 6 | 38 | 104 | 0 | 148 | 0 | 242 | 11 | 0 | 253 | 659 |
| Total Volume | 46 | 195 | 8 | 0 | 249 | 253 | 517 | 9 | 0 | 779 | 19 | 162 | 506 | 0 | 687 | 0 | 999 | 44 | 0 | 1043 | 2758 |
| % App. Total | 18.5 | 78.3 | 3.2 | 0 | | 32.5 | 66.4 | 1.2 | 0 | | 2.8 | 23.6 | 73.7 | 0 | | 0 | 95.8 | 4.2 | 0 | | |
| PHF | .676 | .762 | .667 | .000 | .750 | .832 | .937 | .563 | .000 | .950 | .792 | .862 | .944 | .000 | .928 | .000 | .838 | .786 | .000 | .836 | .933 |

