

Associated Consulting Services (ACS)
 Roseville, MN 55113
 -- TRAFFIC DATA --

MN-56 at CSAH-86_2022

City: Dakota Cnty

Data Prepared By: ACS

TURNING MOVEMENT COUNT

File Name : MN-56 at CSAH-86_2022

Site Code :

Start Date : 5/3/2022

Page No : 1

Groups Printed- Cars - Trucks

Start Time	MN-56 Southbound				CSAH 86 Westbound				MN-56 Northbound				CSAH 86 Eastbound				Int. Total
	Left	Thru	Right	Peds	Left	Thru	Right	Peds	Left	Thru	Right	Peds	Left	Thru	Right	Peds	
06:00	1	3	2	0	3	10	0	0	3	25	2	0	1	9	2	0	61
06:15	0	14	0	0	4	12	0	0	5	36	7	0	0	10	0	0	88
06:30	1	10	2	0	1	20	0	0	3	33	5	0	2	13	1	0	91
06:45	1	10	0	0	5	10	0	0	4	21	7	0	0	19	3	0	80
Total	3	37	4	0	13	52	0	0	15	115	21	0	3	51	6	0	320
07:00	0	20	1	0	4	8	1	0	3	33	1	0	1	11	4	0	87
07:15	1	24	0	0	8	16	0	0	4	37	2	0	4	14	3	0	113
07:30	1	25	1	0	7	17	1	0	7	23	3	0	7	8	1	0	101
07:45	0	35	4	0	7	19	0	0	1	34	1	0	13	23	4	0	141
Total	2	104	6	0	26	60	2	0	15	127	7	0	25	56	12	0	442
08:00	0	11	2	0	5	10	0	0	12	25	2	0	7	17	3	0	94
08:15	1	14	1	0	2	11	0	0	2	14	4	0	2	20	2	0	73
08:30	1	12	1	0	4	9	2	0	4	17	0	0	1	7	1	0	59
08:45	1	16	1	0	0	11	0	0	2	15	1	0	0	22	0	0	69
Total	3	53	5	0	11	41	2	0	20	71	7	0	10	66	6	0	295
09:00	1	14	2	0	2	9	1	0	3	17	2	0	1	12	1	0	65
09:15	1	9	1	0	1	9	1	0	0	9	4	0	3	8	2	0	48
09:30	0	9	1	0	2	8	0	0	3	12	2	0	2	6	3	0	48
09:45	0	3	1	0	1	12	0	0	1	14	3	0	6	12	3	0	56
Total	2	35	5	0	6	38	2	0	7	52	11	0	12	38	9	0	217
10:00	1	12	1	0	3	8	1	0	3	10	1	0	1	8	0	0	49
10:15	2	15	0	0	7	6	0	0	3	13	1	0	0	10	1	0	58
10:30	1	8	2	0	2	10	1	0	1	17	3	0	1	15	1	0	62
10:45	0	16	4	0	0	7	2	0	2	12	2	0	0	12	0	0	57
Total	4	51	7	0	12	31	4	0	9	52	7	0	2	45	2	0	226
11:00	0	11	0	0	4	6	0	0	0	7	1	0	2	6	1	0	38
11:15	1	7	1	0	2	10	1	0	1	10	0	0	1	10	0	0	44
11:30	1	13	0	0	1	11	1	0	4	13	1	0	1	11	4	0	61
11:45	0	8	2	0	1	10	1	0	5	16	1	0	1	16	3	0	64
Total	2	39	3	0	8	37	3	0	10	46	3	0	5	43	8	0	207
12:00	0	13	1	0	1	12	2	0	0	9	1	0	2	18	2	0	61
12:15	1	13	0	0	3	10	0	0	2	6	2	0	0	14	8	0	59
12:30	1	8	2	0	1	6	1	0	9	13	1	0	3	7	3	0	55
12:45	0	6	0	0	2	9	0	0	4	8	1	0	4	8	2	0	44
Total	2	40	3	0	7	37	3	0	15	36	5	0	9	47	15	0	219
13:00	1	15	2	0	2	8	1	0	6	8	2	0	1	13	5	0	64
13:15	1	16	1	0	2	16	1	0	3	12	6	0	3	7	3	0	71
13:30	1	20	5	0	1	12	2	0	3	9	2	0	2	11	3	0	71
13:45	1	18	0	0	2	6	0	0	3	11	1	0	3	9	3	0	57
Total	4	69	8	0	7	42	4	0	15	40	11	0	9	40	14	0	263
14:00	2	15	4	0	6	16	3	0	3	14	2	0	1	13	2	0	81
14:15	1	15	2	0	2	12	2	0	6	18	4	0	0	16	3	0	81
14:30	0	18	1	0	2	13	0	0	4	18	3	0	0	13	4	0	76
14:45	1	21	3	0	2	15	1	0	2	9	1	0	12	28	4	0	99
Total	4	69	10	0	12	56	6	0	15	59	10	0	13	70	13	0	337

Associated Consulting Services (ACS)
 Roseville, MN 55113
 -- TRAFFIC DATA --

MN-56 at CSAH-86_2022

City: Dakota Cnty

Data Prepared By: ACS

TURNING MOVEMENT COUNT

File Name : MN-56 at CSAH-86_2022

Site Code :

Start Date : 5/3/2022

Page No : 2

Groups Printed- Cars - Trucks

Start Time	MN-56 Southbound				CSAH 86 Westbound				MN-56 Northbound				CSAH 86 Eastbound				Int. Total
	Left	Thru	Right	Peds	Left	Thru	Right	Peds	Left	Thru	Right	Peds	Left	Thru	Right	Peds	
15:00	0	21	1	0	0	16	0	0	2	10	8	0	1	15	5	0	79
15:15	3	32	0	0	1	11	1	0	1	15	2	0	2	19	2	0	89
15:30	2	28	3	0	0	19	3	0	4	20	5	0	1	14	3	0	102
15:45	2	22	4	0	2	18	2	0	4	22	1	0	2	17	6	0	102
Total	7	103	8	0	3	64	6	0	11	67	16	0	6	65	16	0	372
16:00	0	33	3	0	4	20	0	0	10	12	2	0	4	16	2	0	106
16:15	0	26	2	0	6	19	3	0	7	23	2	0	0	17	9	0	114
16:30	0	35	1	0	2	11	2	0	1	20	6	0	3	16	10	0	107
16:45	2	35	3	0	1	25	0	0	4	19	2	0	0	13	7	0	111
Total	2	129	9	0	13	75	5	0	22	74	12	0	7	62	28	0	438
17:00	0	33	2	0	2	21	0	0	5	19	3	0	2	13	4	0	104
17:15	0	25	2	0	8	14	0	0	6	17	4	0	0	16	5	0	97
17:30	1	31	2	0	2	12	1	0	3	9	2	0	0	15	5	0	83
17:45	3	33	5	0	4	12	2	0	1	18	5	0	4	11	5	0	103
Total	4	122	11	0	16	59	3	0	15	63	14	0	6	55	19	0	387
Grand Total	39	851	79	0	134	592	40	0	169	802	124	0	107	638	148	0	3723
Apprch %	4	87.8	8.2	0	17.5	77.3	5.2	0	15.4	73.2	11.3	0	12	71.4	16.6	0	
Total %	1	22.9	2.1	0	3.6	15.9	1.1	0	4.5	21.5	3.3	0	2.9	17.1	4	0	
Cars	36	716	67	0	114	485	37	0	139	671	88	0	95	525	124	0	3097
% Cars	92.3	84.1	84.8	0	85.1	81.9	92.5	0	82.2	83.7	71	0	88.8	82.3	83.8	0	83.2
Trucks	3	135	12	0	20	107	3	0	30	131	36	0	12	113	24	0	626
% Trucks	7.7	15.9	15.2	0	14.9	18.1	7.5	0	17.8	16.3	29	0	11.2	17.7	16.2	0	16.8

Associated Consulting Services (ACS)
 Roseville, MN 55113
 -- TRAFFIC DATA --

MN-56 at CSAH-86_2022
 City: Dakota Cnty
 Data Prepared By: ACS
 TURNING MOVEMENT COUNT

File Name : MN-56 at CSAH-86_2022
 Site Code :
 Start Date : 5/3/2022
 Page No : 3

Start Time	MN-56 Southbound					CSAH 86 Westbound					MN-56 Northbound					CSAH 86 Eastbound					Int. Total
	Left	Thru	Right	Peds	App. Total	Left	Thru	Right	Peds	App. Total	Left	Thru	Right	Peds	App. Total	Left	Thru	Right	Peds	App. Total	
Peak Hour Analysis From 06:00 to 11:45 - Peak 1 of 1																					
Peak Hour for Entire Intersection Begins at 07:15																					
07:15	1	24	0	0	25	8	16	0	0	24	4	37	2	0	43	4	14	3	0	21	113
07:30	1	25	1	0	27	7	17	1	0	25	7	23	3	0	33	7	8	1	0	16	101
07:45	0	35	4	0	39	7	19	0	0	26	1	34	1	0	36	13	23	4	0	40	141
08:00	0	11	2	0	13	5	10	0	0	15	12	25	2	0	39	7	17	3	0	27	94
Total Volume	2	95	7	0	104	27	62	1	0	90	24	119	8	0	151	31	62	11	0	104	449
% App. Total	1.9	91.3	6.7	0		30	68.9	1.1	0		15.9	78.8	5.3	0		29.8	59.6	10.6	0		
PHF	.500	.679	.438	.000	.667	.844	.816	.250	.000	.865	.500	.804	.667	.000	.878	.596	.674	.688	.000	.650	.796

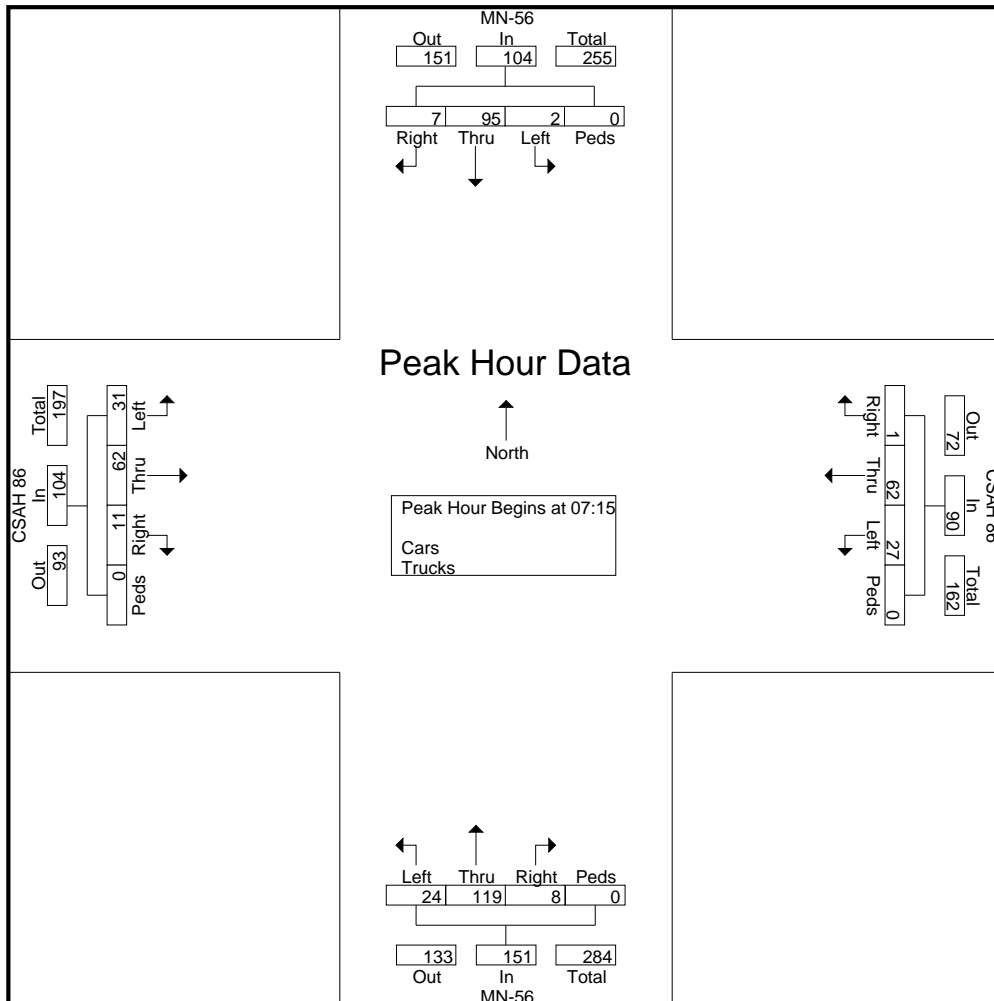

Associated Consulting Services (ACS)
 Roseville, MN 55113
 -- TRAFFIC DATA --

MN-56 at CSAH-86_2022
 City: Dakota Cnty
 Data Prepared By: ACS
 TURNING MOVEMENT COUNT

File Name : MN-56 at CSAH-86_2022
 Site Code :
 Start Date : 5/3/2022
 Page No : 4

Start Time	MN-56 Southbound					CSAH 86 Westbound					MN-56 Northbound					CSAH 86 Eastbound					Int. Total
	Left	Thru	Right	Peds	App. Total	Left	Thru	Right	Peds	App. Total	Left	Thru	Right	Peds	App. Total	Left	Thru	Right	Peds	App. Total	
Peak Hour Analysis From 12:00 to 17:45 - Peak 1 of 1																					
Peak Hour for Entire Intersection Begins at 16:00																					
16:00	0	33	3	0	36	4	20	0	0	24	10	12	2	0	24	4	16	2	0	22	106
16:15	0	26	2	0	28	6	19	3	0	28	7	23	2	0	32	0	17	9	0	26	114
16:30	0	35	1	0	36	2	11	2	0	15	1	20	6	0	27	3	16	10	0	29	107
16:45	2	35	3	0	40	1	25	0	0	26	4	19	2	0	25	0	13	7	0	20	111
Total Volume	2	129	9	0	140	13	75	5	0	93	22	74	12	0	108	7	62	28	0	97	438
% App. Total	1.4	92.1	6.4	0		14	80.6	5.4	0		20.4	68.5	11.1	0		7.2	63.9	28.9	0		
PHF	.250	.921	.750	.000	.875	.542	.750	.417	.000	.830	.550	.804	.500	.000	.844	.438	.912	.700	.000	.836	.961

