



MINNESOTA DEPT OF TRANSPORTATION

TRAFFIC DATA COLLECTION - METRO

Location: TH-110 AT CHARLTON ST / RD

File Name : TH-110 AT CHARLTON ST 2010

Ref.Pt.: 003.275

Site Code : 00000000

JAMAR# 632 DR

Start Date : 4/21/2010

TURN MOVEMENT COUNT

Page No : 1

Groups Printed- Unshifted

Start Time	CHARLTON ST RD Southbound				TH 110 Westbound				CHARLTON ST RD Northbound				TH 110 Eastbound				Int. Total
	Left	Thru	Right	Peds	Left	Thru	Right	Peds	Left	Thru	Right	Peds	Left	Thru	Right	Peds	
06:00	1	0	19	0	1	116	1	0	0	0	0	0	5	42	0	0	185
06:15	0	0	14	0	0	155	3	0	0	0	0	0	11	69	0	0	252
06:30	0	0	17	0	0	211	2	0	0	0	0	0	11	90	0	0	331
06:45	0	0	30	0	0	298	5	0	0	0	1	0	20	118	1	0	473
Total	1	0	80	0	1	780	11	0	0	0	1	0	47	319	1	0	1241
07:00	1	0	29	0	0	266	8	0	0	0	2	0	13	104	1	0	424
07:15	0	0	23	0	1	354	16	0	0	0	1	0	19	147	0	0	561
07:30	0	0	55	0	0	393	9	0	0	0	1	0	21	178	1	0	658
07:45	0	0	37	0	3	320	10	0	1	0	4	0	41	269	3	0	688
Total	1	0	144	0	4	1333	43	0	1	0	8	0	94	698	5	0	2331
08:00	1	1	24	0	0	252	7	0	0	0	6	0	24	181	1	0	497
08:15	1	0	28	0	3	277	16	0	0	0	2	0	25	227	1	0	580
08:30	1	0	20	0	2	267	6	0	0	0	0	0	35	181	2	0	514
08:45	2	0	29	0	2	249	12	0	0	0	3	0	37	184	2	0	520
Total	5	1	101	0	7	1045	41	0	0	0	11	0	121	773	6	0	2111
*** BREAK ***																	
15:00	0	0	24	0	1	196	8	0	0	0	4	0	36	238	0	0	507
15:15	0	0	24	0	2	184	17	0	0	0	3	0	46	292	3	0	571
15:30	0	0	39	0	1	222	7	0	0	0	2	0	31	342	3	0	647
15:45	1	0	33	0	2	196	20	0	0	0	4	0	33	332	0	0	621
Total	1	0	120	0	6	798	52	0	0	0	13	0	146	1204	6	0	2346
16:00	0	0	27	0	0	243	8	0	1	0	1	0	33	317	1	0	631
16:15	0	0	20	0	0	209	13	0	0	1	3	0	40	332	2	0	620
16:30	0	0	17	0	0	261	13	0	0	0	2	0	59	342	2	0	696
16:45	0	0	16	0	1	266	18	0	0	0	2	0	56	355	1	0	715
Total	0	0	80	0	1	979	52	0	1	1	8	0	188	1346	6	0	2662
17:00	0	0	47	0	3	259	11	0	1	0	0	0	47	334	1	0	703
17:15	0	0	21	0	4	301	17	0	0	0	0	0	54	304	0	0	701
17:30	0	0	21	0	1	246	18	0	0	0	2	0	44	307	3	0	642
17:45	1	0	21	0	3	228	15	0	0	0	5	0	56	255	1	0	585
Total	1	0	110	0	11	1034	61	0	1	0	7	0	201	1200	5	0	2631
Grand Total	9	1	635	0	30	5969	260	0	3	1	48	0	797	5540	29	0	13322
Approch %	1.4	0.2	98.4	0	0.5	95.4	4.2	0	5.8	1.9	92.3	0	12.5	87	0.5	0	
Total %	0.1	0	4.8	0	0.2	44.8	2	0	0	0	0.4	0	6	41.6	0.2	0	



MINNESOTA DEPT OF TRANSPORTATION

TRAFFIC DATA COLLECTION - METRO

Location: TH-110 AT CHARLTON ST / RD
 Ref.Pt.: 003.275
 JAMAR# 632 DR
 TURN MOVEMENT COUNT

File Name : TH-110 AT CHARLTON ST 2010
 Site Code : 00000000
 Start Date : 4/21/2010
 Page No : 2

Start Time	CHARLTON ST RD Southbound					TH 110 Westbound					CHARLTON ST RD Northbound					TH 110 Eastbound					Int. Total
	Left	Thru	Right	Peds	App. Total	Left	Thru	Right	Peds	App. Total	Left	Thru	Right	Peds	App. Total	Left	Thru	Right	Peds	App. Total	
Peak Hour Analysis From 06:00 to 08:45 - Peak 1 of 1																					
Peak Hour for Entire Intersection Begins at 07:30																					
07:30	0	0	55	0	55	0	393	9	0	402	0	0	1	0	1	21	178	1	0	200	658
07:45	0	0	37	0	37	3	320	10	0	333	1	0	4	0	5	41	269	3	0	313	688
08:00	1	1	24	0	26	0	252	7	0	259	0	0	6	0	6	24	181	1	0	206	497
08:15	1	0	28	0	29	3	277	16	0	296	0	0	2	0	2	25	227	1	0	253	580
Total Volume	2	1	144	0	147	6	1242	42	0	1290	1	0	13	0	14	111	855	6	0	972	2423
% App. Total	1.4	0.7	98	0		0.5	96.3	3.3	0		7.1	0	92.9	0		11.4	88	0.6	0		
PHF	.500	.250	.655	.000	.668	.500	.790	.656	.000	.802	.250	.000	.542	.000	.583	.677	.795	.500	.000	.776	.880

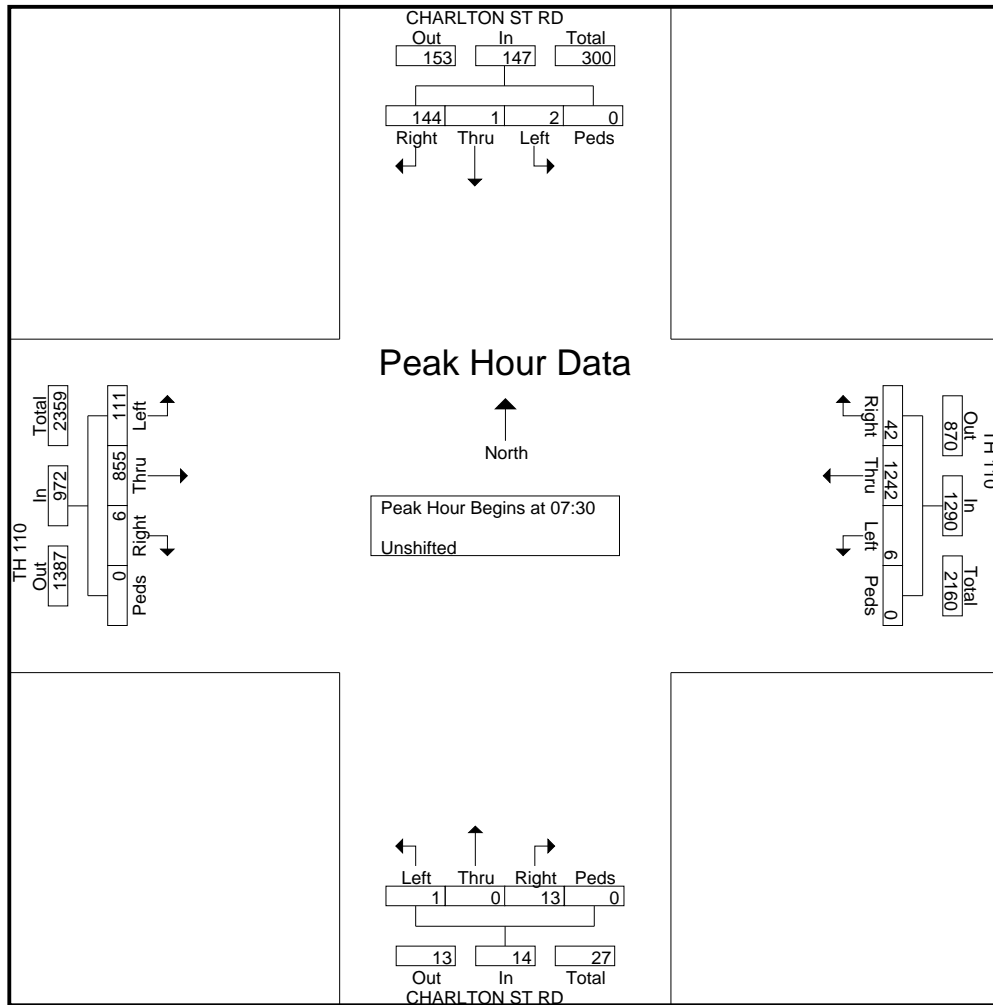



MINNESOTA DEPT OF TRANSPORTATION

TRAFFIC DATA COLLECTION - METRO

Location: TH-110 AT CHARLTON ST / RD
 Ref.Pt.: 003.275
 JAMAR# 632 DR
 TURN MOVEMENT COUNT

File Name : TH-110 AT CHARLTON ST 2010
 Site Code : 00000000
 Start Date : 4/21/2010
 Page No : 3

Start Time	CHARLTON ST RD Southbound					TH 110 Westbound					CHARLTON ST RD Northbound					TH 110 Eastbound					Int. Total
	Left	Thru	Right	Peds	App. Total	Left	Thru	Right	Peds	App. Total	Left	Thru	Right	Peds	App. Total	Left	Thru	Right	Peds	App. Total	
Peak Hour Analysis From 15:00 to 17:45 - Peak 1 of 1																					
Peak Hour for Entire Intersection Begins at 16:30																					
16:30	0	0	17	0	17	0	261	13	0	274	0	0	2	0	2	59	342	2	0	403	696
16:45	0	0	16	0	16	1	266	18	0	285	0	0	2	0	2	56	355	1	0	412	715
17:00	0	0	47	0	47	3	259	11	0	273	1	0	0	0	1	47	334	1	0	382	703
17:15	0	0	21	0	21	4	301	17	0	322	0	0	0	0	0	54	304	0	0	358	701
Total Volume	0	0	101	0	101	8	1087	59	0	1154	1	0	4	0	5	216	1335	4	0	1555	2815
% App. Total	0	0	100	0		0.7	94.2	5.1	0		20	0	80	0		13.9	85.9	0.3	0		
PHF	.000	.000	.537	.000	.537	.500	.903	.819	.000	.896	.250	.000	.500	.000	.625	.915	.940	.500	.000	.944	.984

