

Alliant Engineering Inc Minneapolis, MN 55415

TH-65 at 81st Ave NE SPRING LAKE PARK
 Ref.Pt.: 009.682
 Data by Alliant Engineering Inc
 TURN MOVEMENT COUNT

File Name : TH-65 at 81st Ave NE 2009
 Site Code : 00000008
 Start Date : 1/7/2009
 Page No : 1

Groups Printed- Unshifted

Start Time	TH-65 Southbound				81st Ave NE Westbound				TH-65 Northbound				81st Ave NE Eastbound				Int. Total
	Left	Thru	Right	Peds	Left	Thru	Right	Peds	Left	Thru	Right	Peds	Left	Thru	Right	Peds	
06:00	18	305	30	0	2	4	6	0	3	46	4	0	9	3	11	0	441
06:15	15	398	39	0	2	3	6	0	7	49	4	0	8	3	11	0	545
06:30	15	450	31	1	5	5	9	0	6	78	9	1	10	9	9	0	638
06:45	23	411	40	1	5	9	14	0	6	81	12	0	17	9	26	1	655
Total	71	1564	140	2	14	21	35	0	22	254	29	1	44	24	57	1	2279
07:00	29	458	28	1	9	11	21	0	12	89	12	1	27	9	13	1	721
07:15	20	478	20	8	12	9	20	1	10	112	6	9	25	7	15	6	758
07:30	28	466	23	3	10	12	17	0	8	127	8	4	24	16	27	3	776
07:45	42	562	27	0	11	16	24	0	11	131	12	4	29	15	15	6	905
Total	119	1964	98	12	42	48	82	1	41	459	38	18	105	47	70	16	3160
08:00	37	470	36	1	10	19	17	0	7	143	12	0	45	24	26	0	847
08:15	26	394	47	0	18	20	24	0	8	133	14	2	52	16	22	0	776
08:30	15	300	24	0	8	11	23	0	10	120	19	0	24	16	21	0	591
08:45	25	294	33	0	5	15	10	0	8	132	11	0	16	10	12	0	571
Total	103	1458	140	1	41	65	74	0	33	528	56	2	137	66	81	0	2785
09:00	15	240	30	0	11	7	18	0	12	123	5	0	20	11	23	0	515
09:15	19	224	29	0	2	10	9	0	5	132	15	0	19	15	14	0	493
*** BREAK ***																	
Total	34	464	59	0	13	17	27	0	17	255	20	0	39	26	37	0	1008
*** BREAK ***																	
10:30	17	157	14	0	6	21	15	0	14	118	10	0	13	9	18	0	412
10:45	19	187	21	0	10	14	28	0	8	140	12	0	20	16	18	0	493
Total	36	344	35	0	16	35	43	0	22	258	22	0	33	25	36	0	905
11:00	20	158	18	0	8	12	18	0	7	159	11	0	17	8	10	0	446
11:15	11	197	17	0	12	23	27	0	21	182	9	0	24	11	13	0	547
11:30	16	166	36	0	16	28	29	0	22	171	7	0	24	18	15	0	548
11:45	17	189	31	0	5	20	37	0	24	218	12	0	35	27	16	0	631
Total	64	710	102	0	41	83	111	0	74	730	39	0	100	64	54	0	2172
12:00	24	144	41	0	11	22	19	0	23	179	9	0	51	18	15	0	556
12:15	21	200	28	3	13	19	19	0	27	175	10	1	29	20	17	0	582
12:30	17	223	23	0	11	23	32	0	18	162	15	0	29	35	21	0	609
12:45	19	268	20	0	11	23	21	0	14	168	8	1	43	21	17	0	634
Total	81	835	112	3	46	87	91	0	82	684	42	2	152	94	70	0	2381
13:00	23	194	24	1	11	11	29	0	15	190	9	1	38	23	16	1	586
13:15	19	164	27	0	11	12	24	0	20	176	12	0	26	18	16	0	525
*** BREAK ***																	
Total	42	358	51	1	22	23	53	0	35	366	21	1	64	41	32	1	1111
*** BREAK ***																	
14:30	26	231	32	0	16	17	51	0	33	322	13	0	64	26	19	0	850
14:45	24	231	30	0	10	21	41	0	14	291	46	3	60	27	16	0	814
Total	50	462	62	0	26	38	92	0	47	613	59	3	124	53	35	0	1664
15:00	24	189	25	0	15	16	82	0	19	281	20	0	48	17	28	0	764
15:15	26	232	24	1	12	15	69	0	22	315	14	0	54	15	18	0	817
15:30	16	215	23	0	15	26	55	0	17	365	15	0	54	15	15	0	831
15:45	26	218	17	1	11	24	48	0	19	409	14	0	41	16	17	0	861
Total	92	854	89	2	53	81	254	0	77	1370	63	0	197	63	78	0	3273

Alliant Engineering Inc

Minneapolis, MN 55415

TH-65 at 81st Ave NE SPRING LAKE PARK
 Ref.Pt.: 009.682
 Data by Alliant Engineering Inc
 TURN MOVEMENT COUNT

File Name : TH-65 at 81st Ave NE 2009
 Site Code : 00000008
 Start Date : 1/7/2009
 Page No : 2

Groups Printed- Unshifted

Start Time	TH-65 Southbound				81st Ave NE Westbound				TH-65 Northbound				81st Ave NE Eastbound				Int. Total
	Left	Thru	Right	Peds	Left	Thru	Right	Peds	Left	Thru	Right	Peds	Left	Thru	Right	Peds	
16:00	21	189	27	0	9	16	63	1	27	348	14	0	60	29	17	0	821
16:15	20	213	23	0	13	32	64	0	17	427	19	0	41	23	12	0	904
16:30	15	246	19	0	17	27	87	0	29	428	11	0	40	18	25	0	962
16:45	17	247	20	0	10	18	74	0	20	461	6	0	49	15	10	0	947
Total	73	895	89	0	49	93	288	1	93	1664	50	0	190	85	64	0	3634
17:00	16	231	20	0	16	17	102	0	25	450	13	0	36	10	14	0	950
17:15	18	193	32	0	8	32	73	0	33	472	11	0	31	15	20	0	938
17:30	16	203	23	0	10	24	57	0	21	444	17	1	56	25	12	0	909
17:45	13	220	24	0	15	18	69	1	23	381	17	0	41	12	10	0	844
Total	63	847	99	0	49	91	301	1	102	1747	58	1	164	62	56	0	3641
Grand Total	828	10755	1076	21	412	682	1451	3	645	8928	497	28	1349	650	670	18	28013
Apprch %	6.5	84.8	8.5	0.2	16.2	26.8	56.9	0.1	6.4	88.4	4.9	0.3	50.2	24.2	24.9	0.7	
Total %	3	38.4	3.8	0.1	1.5	2.4	5.2	0	2.3	31.9	1.8	0.1	4.8	2.3	2.4	0.1	

Alliant Engineering Inc Minneapolis, MN 55415

TH-65 at 81st Ave NE SPRING LAKE PARK
 Ref.Pt.: 009.682
 Data by Alliant Engineering Inc
 TURN MOVEMENT COUNT

File Name : TH-65 at 81st Ave NE 2009
 Site Code : 00000008
 Start Date : 1/7/2009
 Page No : 3

Start Time	TH-65 Southbound					81st Ave NE Westbound					TH-65 Northbound					81st Ave NE Eastbound					Int. Total
	Left	Thru	Right	Peds	App. Total	Left	Thru	Right	Peds	App. Total	Left	Thru	Right	Peds	App. Total	Left	Thru	Right	Peds	App. Total	
Peak Hour Analysis From 06:00 to 08:45 - Peak 1 of 1																					
Peak Hour for Entire Intersection Begins at 07:30																					
07:30	28	466	23	3	520	10	12	17	0	39	8	127	8	4	147	24	16	27	3	70	776
07:45	42	562	27	0	631	11	16	24	0	51	11	131	12	4	158	29	15	15	6	65	905
08:00	37	470	36	1	544	10	19	17	0	46	7	143	12	0	162	45	24	26	0	95	847
08:15	26	394	47	0	467	18	20	24	0	62	8	133	14	2	157	52	16	22	0	90	776
Total Volume	133	1892	133	4	2162	49	67	82	0	198	34	534	46	10	624	150	71	90	9	320	3304
% App. Total	6.2	87.5	6.2	0.2		24.7	33.8	41.4	0		5.4	85.6	7.4	1.6		46.9	22.2	28.1	2.8		
PHF	.792	.842	.707	.333	.857	.681	.838	.854	.000	.798	.773	.934	.821	.625	.963	.721	.740	.833	.375	.842	.913

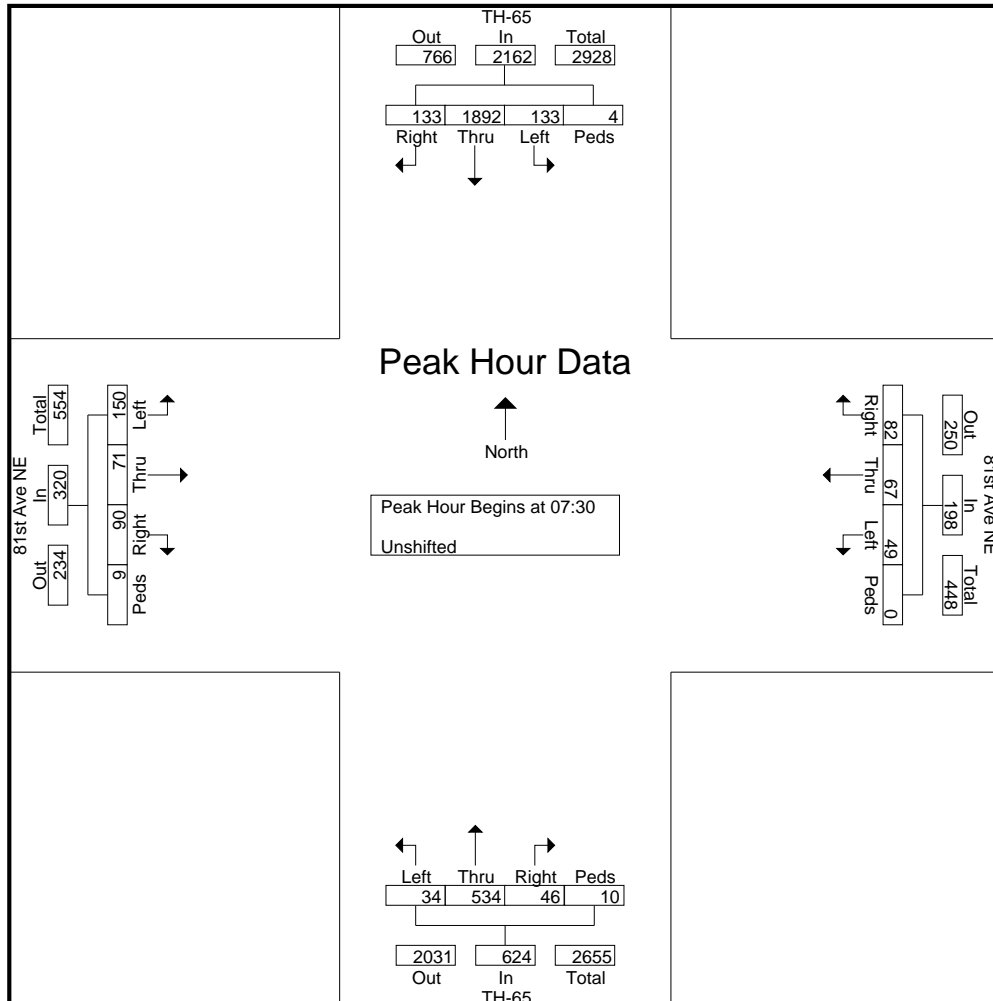

Alliant Engineering Inc Minneapolis, MN 55415

TH-65 at 81st Ave NE SPRING LAKE PARK
 Ref.Pt.: 009.682
 Data by Alliant Engineering Inc
 TURN MOVEMENT COUNT

File Name : TH-65 at 81st Ave NE 2009
 Site Code : 00000008
 Start Date : 1/7/2009
 Page No : 4

Start Time	TH-65 Southbound					81st Ave NE Westbound					TH-65 Northbound					81st Ave NE Eastbound					Int. Total
	Left	Thru	Right	Peds	App. Total	Left	Thru	Right	Peds	App. Total	Left	Thru	Right	Peds	App. Total	Left	Thru	Right	Peds	App. Total	
Peak Hour Analysis From 15:00 to 17:45 - Peak 1 of 1																					
Peak Hour for Entire Intersection Begins at 16:30																					
16:30	15	246	19	0	280	17	27	87	0	131	29	428	11	0	468	40	18	25	0	83	962
16:45	17	247	20	0	284	10	18	74	0	102	20	461	6	0	487	49	15	10	0	74	947
17:00	16	231	20	0	267	16	17	102	0	135	25	450	13	0	488	36	10	14	0	60	950
17:15	18	193	32	0	243	8	32	73	0	113	33	472	11	0	516	31	15	20	0	66	938
Total Volume	66	917	91	0	1074	51	94	336	0	481	107	1811	41	0	1959	156	58	69	0	283	3797
% App. Total	6.1	85.4	8.5	0		10.6	19.5	69.9	0		5.5	92.4	2.1	0		55.1	20.5	24.4	0		
PHF	.917	.928	.711	.000	.945	.750	.734	.824	.000	.891	.811	.959	.788	.000	.949	.796	.806	.690	.000	.852	.987

