

Alliant Engineering Inc Minneapolis, MN 55415

TH-65 at 147th Ave NE / Andover Blvd NE
 Ref.Pt.: 018.186
 data by Alliant Engineering Inc
 TURN MOVEMENT COUNT

File Name : TH-65 at 147th Ave NE-Andover Blvd 2009
 Site Code : 00000019
 Start Date : 1/15/2009
 Page No : 1

Groups Printed- Unshifted

Start Time	TH-65 Southbound				147th Ave NE Westbound				TH-65 Northbound				Andover Blvd NE Eastbound				Int. Total
	Left	Thru	Right	Peds	Left	Thru	Right	Peds	Left	Thru	Right	Peds	Left	Thru	Right	Peds	
06:00	0	446	3	0	5	0	2	0	0	32	0	0	0	0	11	0	499
06:15	0	441	0	0	1	2	0	0	1	51	1	0	0	1	18	0	516
06:30	0	462	9	0	5	0	1	0	2	63	0	0	2	2	19	0	565
06:45	2	383	1	0	5	3	0	0	4	57	2	0	0	1	8	0	466
Total	2	1732	13	0	16	5	3	0	7	203	3	0	2	4	56	0	2046
07:00	2	376	4	0	10	4	1	0	5	52	1	0	3	0	17	0	475
07:15	3	400	3	0	12	5	0	0	5	77	4	0	2	2	24	0	537
07:30	3	373	9	0	7	1	1	0	4	103	3	0	1	2	18	0	525
07:45	4	304	7	0	8	3	0	0	9	97	2	0	8	2	21	0	465
Total	12	1453	23	0	37	13	2	0	23	329	10	0	14	6	80	0	2002
08:00	5	248	4	0	3	1	2	0	5	93	2	0	1	1	12	0	377
08:15	1	240	4	0	4	0	0	0	3	93	3	0	1	1	14	0	364
08:30	1	237	5	0	6	1	2	0	8	83	6	0	2	1	14	0	366
08:45	3	218	3	0	4	1	1	0	7	88	2	0	1	1	18	0	347
Total	10	943	16	0	17	3	5	0	23	357	13	0	5	4	58	0	1454
09:00	0	190	5	0	3	1	1	0	4	98	1	0	4	0	13	0	320
09:15	2	204	5	0	3	0	0	0	4	107	5	0	1	2	13	0	346
*** BREAK ***																	
Total	2	394	10	0	6	1	1	0	8	205	6	0	5	2	26	0	666
*** BREAK ***																	
10:30	1	153	1	0	1	0	0	0	8	88	7	0	1	1	7	0	268
10:45	3	161	2	0	3	0	1	0	7	80	5	0	4	1	4	0	271
Total	4	314	3	0	4	0	1	0	15	168	12	0	5	2	11	0	539
11:00	1	185	2	0	4	2	2	0	8	117	8	0	3	1	13	0	346
11:15	1	138	2	0	6	2	2	0	8	113	7	0	3	2	6	0	290
11:30	1	158	1	0	4	1	0	0	8	110	5	0	2	1	12	0	303
11:45	0	168	5	0	5	1	1	0	9	101	3	0	3	0	7	0	303
Total	3	649	10	0	19	6	5	0	33	441	23	0	11	4	38	0	1242
12:00	2	127	3	0	5	1	0	0	7	131	9	0	3	1	9	0	298
12:15	2	164	2	0	4	0	0	0	12	123	11	0	5	1	6	0	330
12:30	1	143	1	0	3	2	2	0	7	153	6	0	3	1	7	0	329
12:45	5	151	3	0	6	3	1	0	13	124	3	0	5	1	5	0	320
Total	10	585	9	0	18	6	3	0	39	531	29	0	16	4	27	0	1277
13:00	4	131	2	0	3	4	4	0	11	141	6	0	2	2	3	0	313
13:15	7	160	2	0	4	2	3	0	11	139	2	0	4	0	4	0	338
*** BREAK ***																	
Total	11	291	4	0	7	6	7	0	22	280	8	0	6	2	7	0	651
*** BREAK ***																	
14:30	0	137	3	0	6	2	3	0	13	263	6	0	10	3	7	0	453
14:45	0	129	4	0	3	5	0	0	20	271	9	0	6	1	10	0	458
Total	0	266	7	0	9	7	3	0	33	534	15	0	16	4	17	0	911
15:00	3	113	2	0	6	3	2	0	16	311	11	0	6	0	3	0	476
15:15	2	150	6	0	4	3	7	0	14	302	7	0	3	2	7	0	507
15:30	0	133	3	0	8	1	4	0	11	379	9	0	4	0	7	0	559
15:45	1	151	1	0	4	7	0	0	36	401	9	0	2	3	9	0	624
Total	6	547	12	0	22	14	13	0	77	1393	36	0	15	5	26	0	2166

Alliant Engineering Inc Minneapolis, MN 55415

TH-65 at 147th Ave NE / Andover Blvd NE
 Ref.Pt.: 018.186
 data by Alliant Engineering Inc
 TURN MOVEMENT COUNT

File Name : TH-65 at 147th Ave NE-Andover Blvd 2009
 Site Code : 00000019
 Start Date : 1/15/2009
 Page No : 2

Groups Printed- Unshifted

Start Time	TH-65 Southbound				147th Ave NE Westbound				TH-65 Northbound				Andover Blvd NE Eastbound				Int. Total
	Left	Thru	Right	Peds	Left	Thru	Right	Peds	Left	Thru	Right	Peds	Left	Thru	Right	Peds	
16:00	2	143	1	1	5	5	1	0	23	407	8	0	7	2	4	0	609
16:15	2	158	5	0	3	4	4	0	34	405	14	0	4	3	7	0	643
16:30	7	181	3	0	5	2	7	0	28	469	4	0	7	4	12	0	729
16:45	5	206	5	0	11	7	7	0	32	451	10	0	4	2	14	0	754
Total	16	688	14	1	24	18	19	0	117	1732	36	0	22	11	37	0	2735
17:00	2	241	4	0	5	5	12	0	27	431	11	0	13	3	15	0	769
17:15	1	175	6	0	2	2	7	0	49	438	14	0	5	0	13	0	712
17:30	1	163	8	0	6	4	4	0	32	337	6	0	4	3	9	0	577
17:45	4	135	3	0	4	1	8	0	50	319	5	0	3	2	13	0	547
Total	8	714	21	0	17	12	31	0	158	1525	36	0	25	8	50	0	2605
Grand Total	84	8576	142	1	196	91	93	0	555	7698	227	0	142	56	433	0	18294
Apprch %	1	97.4	1.6	0	51.6	23.9	24.5	0	6.5	90.8	2.7	0	22.5	8.9	68.6	0	
Total %	0.5	46.9	0.8	0	1.1	0.5	0.5	0	3	42.1	1.2	0	0.8	0.3	2.4	0	

Alliant Engineering Inc Minneapolis, MN 55415

TH-65 at 147th Ave NE / Andover Blvd NE
 Ref.Pt.: 018.186
 data by Alliant Engineering Inc
 TURN MOVEMENT COUNT

File Name : TH-65 at 147th Ave NE-Andover Blvd 2009
 Site Code : 00000019
 Start Date : 1/15/2009
 Page No : 3

Start Time	TH-65 Southbound					147th Ave NE Westbound					TH-65 Northbound					Andover Blvd NE Eastbound					Int. Total
	Left	Thru	Right	Peds	App. Total	Left	Thru	Right	Peds	App. Total	Left	Thru	Right	Peds	App. Total	Left	Thru	Right	Peds	App. Total	
Peak Hour Analysis From 06:00 to 08:45 - Peak 1 of 1																					
Peak Hour for Entire Intersection Begins at 06:00																					
06:00	0	446	3	0	449	5	0	2	0	7	0	32	0	0	32	0	0	11	0	11	499
06:15	0	441	0	0	441	1	2	0	0	3	1	51	1	0	53	0	1	18	0	19	516
06:30	0	462	9	0	471	5	0	1	0	6	2	63	0	0	65	2	2	19	0	23	565
06:45	2	383	1	0	386	5	3	0	0	8	4	57	2	0	63	0	1	8	0	9	466
Total Volume	2	1732	13	0	1747	16	5	3	0	24	7	203	3	0	213	2	4	56	0	62	2046
% App. Total	0.1	99.1	0.7	0		66.7	20.8	12.5	0		3.3	95.3	1.4	0		3.2	6.5	90.3	0		
PHF	.250	.937	.361	.000	.927	.800	.417	.375	.000	.750	.438	.806	.375	.000	.819	.250	.500	.737	.000	.674	.905

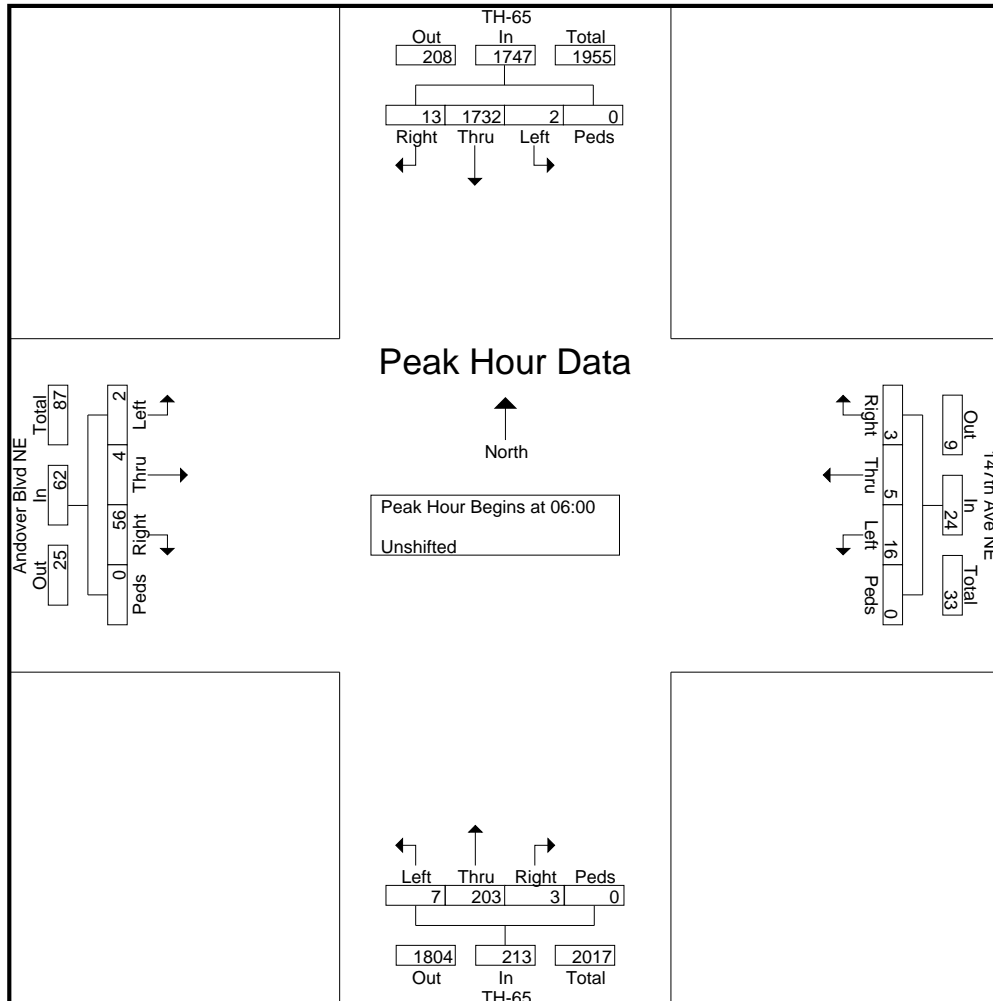

Alliant Engineering Inc Minneapolis, MN 55415

TH-65 at 147th Ave NE / Andover Blvd NE
 Ref.Pt.: 018.186
 data by Alliant Engineering Inc
 TURN MOVEMENT COUNT

File Name : TH-65 at 147th Ave NE-Andover Blvd 2009
 Site Code : 00000019
 Start Date : 1/15/2009
 Page No : 4

Start Time	TH-65 Southbound					147th Ave NE Westbound					TH-65 Northbound					Andover Blvd NE Eastbound					Int. Total
	Left	Thru	Right	Peds	App. Total	Left	Thru	Right	Peds	App. Total	Left	Thru	Right	Peds	App. Total	Left	Thru	Right	Peds	App. Total	
Peak Hour Analysis From 15:00 to 17:45 - Peak 1 of 1																					
Peak Hour for Entire Intersection Begins at 16:30																					
16:30	7	181	3	0	191	5	2	7	0	14	28	469	4	0	501	7	4	12	0	23	729
16:45	5	206	5	0	216	11	7	7	0	25	32	451	10	0	493	4	2	14	0	20	754
17:00	2	241	4	0	247	5	5	12	0	22	27	431	11	0	469	13	3	15	0	31	769
17:15	1	175	6	0	182	2	2	7	0	11	49	438	14	0	501	5	0	13	0	18	712
Total Volume	15	803	18	0	836	23	16	33	0	72	136	1789	39	0	1964	29	9	54	0	92	2964
% App. Total	1.8	96.1	2.2	0		31.9	22.2	45.8	0		6.9	91.1	2	0		31.5	9.8	58.7	0		
PHF	.536	.833	.750	.000	.846	.523	.571	.688	.000	.720	.694	.954	.696	.000	.980	.558	.563	.900	.000	.742	.964

