

Alliant Engineering Inc Minneapolis, MN 55415

TH-65 at Sims Rd NE EAST BETHEL
 Ref.Pt.: 026.417
 data by Alliant Engineering Inc
 TURN MOVEMENT COUNT

File Name : TH-65 at Sims Rd NE 2009
 Site Code : 00000023
 Start Date : 1/20/2009
 Page No : 1

Groups Printed- Unshifted

Start Time	TH-65 Southbound				Sims Rd NE Westbound				TH-65 Northbound				Sims Rd NE Eastbound				Int. Total
	Left	Thru	Right	Peds	Left	Thru	Right	Peds	Left	Thru	Right	Peds	Left	Thru	Right	Peds	
06:00	3	323	3	0	7	1	0	0	2	30	1	0	0	2	38	0	410
06:15	3	376	3	0	3	1	0	0	2	45	2	0	1	0	25	0	461
06:30	6	305	4	0	2	3	0	0	8	56	3	0	7	3	30	0	427
06:45	0	310	3	0	5	2	0	0	12	76	3	0	1	1	28	0	441
Total	12	1314	13	0	17	7	0	0	24	207	9	0	9	6	121	0	1739
07:00	2	316	2	0	0	1	1	0	3	54	7	0	2	2	28	0	418
07:15	3	313	6	0	0	0	0	0	1	36	0	0	2	0	31	0	392
07:30	5	274	11	0	4	1	1	1	5	108	0	0	5	2	29	0	446
07:45	0	213	29	0	7	0	0	0	7	67	3	0	10	4	27	0	367
Total	10	1116	48	0	11	2	2	1	16	265	10	0	19	8	115	0	1623
08:00	4	152	11	0	6	1	0	0	2	78	5	0	10	4	18	0	291
08:15	3	190	3	0	6	3	0	0	8	67	1	0	0	4	11	0	296
08:30	8	186	6	0	6	2	0	0	5	60	10	0	3	6	18	0	310
08:45	6	132	24	0	11	3	2	0	14	63	6	0	2	8	10	0	281
Total	21	660	44	0	29	9	2	0	29	268	22	0	15	22	57	0	1178
09:00	7	118	19	0	20	4	1	0	17	49	2	0	16	11	31	0	295
09:15	5	160	6	0	4	5	1	0	11	63	4	0	3	5	12	0	279
*** BREAK ***																	
Total	12	278	25	0	24	9	2	0	28	112	6	0	19	16	43	0	574
*** BREAK ***																	
10:30	4	88	5	0	9	3	3	0	2	67	6	0	2	2	9	0	200
10:45	1	101	3	0	7	1	1	0	6	71	8	0	5	0	7	0	211
Total	5	189	8	0	16	4	4	0	8	138	14	0	7	2	16	0	411
11:00	2	92	5	0	7	3	3	0	5	53	8	0	2	2	5	0	187
11:15	2	94	6	0	6	6	2	0	3	76	7	0	2	3	3	0	210
11:30	6	96	6	0	6	1	2	2	8	66	6	0	2	2	5	0	208
11:45	1	76	3	0	9	4	2	0	6	80	8	0	3	8	7	0	207
Total	11	358	20	0	28	14	9	2	22	275	29	0	9	15	20	0	812
12:00	2	106	8	0	7	3	0	0	5	80	12	0	6	2	7	0	238
12:15	2	116	6	0	8	3	3	0	9	82	7	0	5	5	9	0	255
12:30	5	102	2	0	4	2	1	0	6	97	5	0	4	5	3	0	236
12:45	5	110	4	0	10	3	0	0	11	105	7	0	3	1	10	0	269
Total	14	434	20	0	29	11	4	0	31	364	31	0	18	13	29	0	998
13:00	1	88	3	0	6	2	4	0	7	96	11	0	3	0	6	0	227
13:15	4	101	1	0	7	3	1	0	4	111	4	0	4	7	2	0	249
*** BREAK ***																	
Total	5	189	4	0	13	5	5	0	11	207	15	0	7	7	8	0	476
*** BREAK ***																	
14:30	13	96	2	0	6	1	0	0	7	164	16	0	0	3	15	0	323
14:45	8	99	8	0	3	4	3	0	8	182	8	0	5	3	8	0	339
Total	21	195	10	0	9	5	3	0	15	346	24	0	5	6	23	0	662
15:00	9	89	2	0	6	8	2	1	12	190	18	0	9	7	6	0	359
15:15	6	115	5	0	5	8	3	0	15	235	13	0	6	8	13	0	432
15:30	5	109	14	0	10	6	4	2	30	293	12	0	5	8	6	0	504
15:45	4	108	11	0	10	7	2	0	19	247	11	0	30	11	15	0	475
Total	24	421	32	0	31	29	11	3	76	965	54	0	50	34	40	0	1770

Alliant Engineering Inc Minneapolis, MN 55415

TH-65 at Sims Rd NE EAST BETHEL
 Ref.Pt.: 026.417
 data by Alliant Engineering Inc
 TURN MOVEMENT COUNT

File Name : TH-65 at Sims Rd NE 2009
 Site Code : 00000023
 Start Date : 1/20/2009
 Page No : 2

Groups Printed- Unshifted

Start Time	TH-65 Southbound				Sims Rd NE Westbound				TH-65 Northbound				Sims Rd NE Eastbound				Int. Total
	Left	Thru	Right	Peds	Left	Thru	Right	Peds	Left	Thru	Right	Peds	Left	Thru	Right	Peds	
16:00	9	95	7	0	7	7	2	0	28	322	11	0	20	7	14	0	529
16:15	7	130	7	0	7	11	4	0	25	338	16	0	18	8	8	0	579
16:30	6	94	7	0	11	5	3	2	17	336	19	0	15	8	13	0	536
16:45	5	127	7	0	8	4	7	0	30	338	15	0	11	3	10	0	565
Total	27	446	28	0	33	27	16	2	100	1334	61	0	64	26	45	0	2209
17:00	5	139	5	0	4	3	5	1	32	379	8	0	13	6	19	0	619
17:15	2	123	6	0	3	7	2	2	23	368	14	0	10	5	12	0	577
17:30	4	97	8	0	6	4	6	0	35	300	6	0	13	4	12	0	495
17:45	2	101	6	0	5	4	4	0	25	244	11	0	12	1	11	0	426
Total	13	460	25	0	18	18	17	3	115	1291	39	0	48	16	54	0	2117
Grand Total	175	6060	277	0	258	140	75	11	475	5772	314	0	270	171	571	0	14569
Apprch %	2.7	93.1	4.3	0	53.3	28.9	15.5	2.3	7.2	88	4.8	0	26.7	16.9	56.4	0	
Total %	1.2	41.6	1.9	0	1.8	1	0.5	0.1	3.3	39.6	2.2	0	1.9	1.2	3.9	0	

Alliant Engineering Inc Minneapolis, MN 55415

TH-65 at Sims Rd NE EAST BETHEL
 Ref.Pt.: 026.417
 data by Alliant Engineering Inc
 TURN MOVEMENT COUNT

File Name : TH-65 at Sims Rd NE 2009
 Site Code : 00000023
 Start Date : 1/20/2009
 Page No : 3

Start Time	TH-65 Southbound					Sims Rd NE Westbound					TH-65 Northbound					Sims Rd NE Eastbound					Int. Total
	Left	Thru	Right	Peds	App. Total	Left	Thru	Right	Peds	App. Total	Left	Thru	Right	Peds	App. Total	Left	Thru	Right	Peds	App. Total	
Peak Hour Analysis From 06:00 to 08:45 - Peak 1 of 1																					
Peak Hour for Entire Intersection Begins at 06:15																					
06:15	3	376	3	0	382	3	1	0	0	4	2	45	2	0	49	1	0	25	0	26	461
06:30	6	305	4	0	315	2	3	0	0	5	8	56	3	0	67	7	3	30	0	40	427
06:45	0	310	3	0	313	5	2	0	0	7	12	76	3	0	91	1	1	28	0	30	441
07:00	2	316	2	0	320	0	1	1	0	2	3	54	7	0	64	2	2	28	0	32	418
Total Volume	11	1307	12	0	1330	10	7	1	0	18	25	231	15	0	271	11	6	111	0	128	1747
% App. Total	0.8	98.3	0.9	0		55.6	38.9	5.6	0		9.2	85.2	5.5	0		8.6	4.7	86.7	0		
PHF	.458	.869	.750	.000	.870	.500	.583	.250	.000	.643	.521	.760	.536	.000	.745	.393	.500	.925	.000	.800	.947

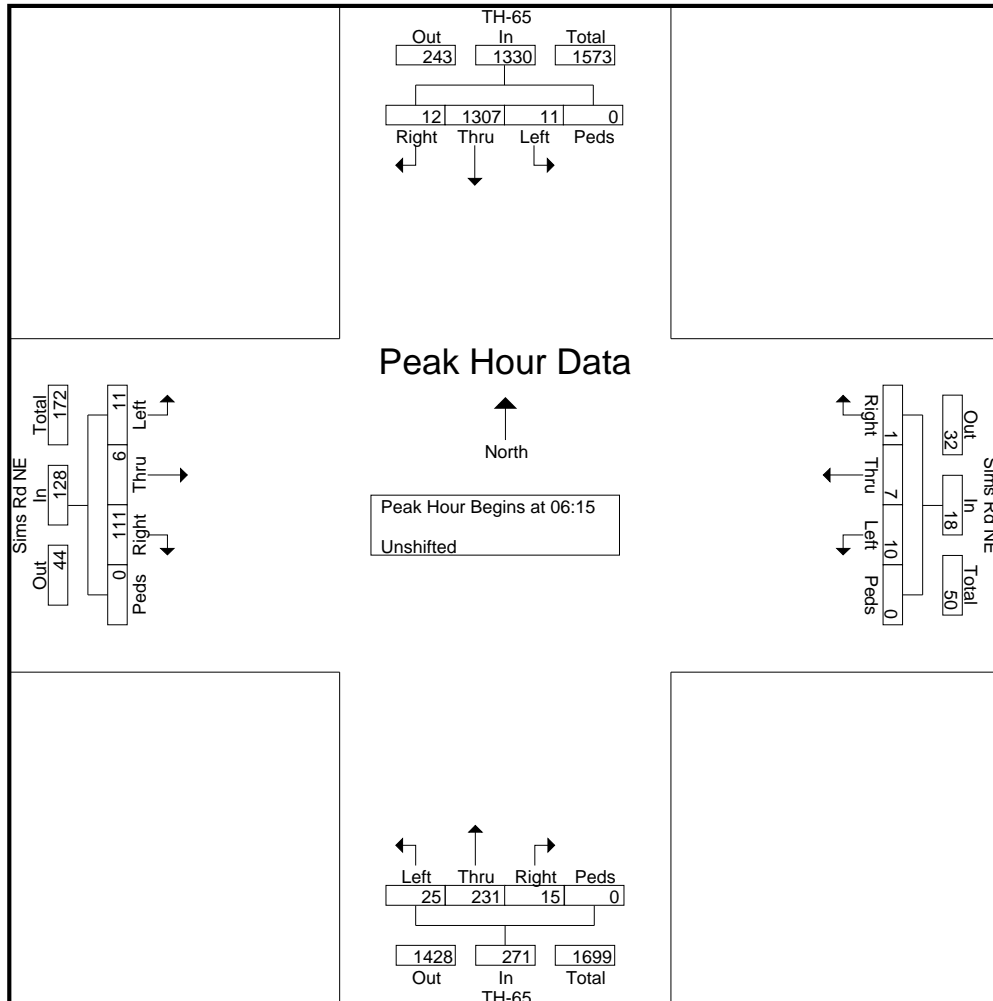

Alliant Engineering Inc Minneapolis, MN 55415

TH-65 at Sims Rd NE EAST BETHEL
 Ref.Pt.: 026.417
 data by Alliant Engineering Inc
 TURN MOVEMENT COUNT

File Name : TH-65 at Sims Rd NE 2009
 Site Code : 00000023
 Start Date : 1/20/2009
 Page No : 4

Start Time	TH-65 Southbound					Sims Rd NE Westbound					TH-65 Northbound					Sims Rd NE Eastbound					Int. Total
	Left	Thru	Right	Peds	App. Total	Left	Thru	Right	Peds	App. Total	Left	Thru	Right	Peds	App. Total	Left	Thru	Right	Peds	App. Total	
Peak Hour Analysis From 15:00 to 17:45 - Peak 1 of 1																					
Peak Hour for Entire Intersection Begins at 16:15																					
16:15	7	130	7	0	144	7	11	4	0	22	25	338	16	0	379	18	8	8	0	34	579
16:30	6	94	7	0	107	11	5	3	2	21	17	336	19	0	372	15	8	13	0	36	536
16:45	5	127	7	0	139	8	4	7	0	19	30	338	15	0	383	11	3	10	0	24	565
17:00	5	139	5	0	149	4	3	5	1	13	32	379	8	0	419	13	6	19	0	38	619
Total Volume	23	490	26	0	539	30	23	19	3	75	104	1391	58	0	1553	57	25	50	0	132	2299
% App. Total	4.3	90.9	4.8	0		40	30.7	25.3	4		6.7	89.6	3.7	0		43.2	18.9	37.9	0		
PHF	.821	.881	.929	.000	.904	.682	.523	.679	.375	.852	.813	.918	.763	.000	.927	.792	.781	.658	.000	.868	.929

