

# Alliant Engineering Inc Minneapolis, MN 55415

Louisiana Ave S at W Lake Street  
Ref,Pt.:  
Alliant Engineering Inc.  
TURN MOVEMENT COUNT

File Name : 26\_Louisiana Ave at Lake St\_010411  
Site Code : 00000026  
Start Date : 1/4/2011  
Page No : 1

### Groups Printed- Unshifted - Bank 1

Start Time	Louisiana Ave S Southbound				W Lake St Westbound				Louisiana Ave S Northbound				W Lake St Eastbound				Int. Total
	Left	Thru	Rght	Peds	Left	Thru	Rght	Peds	Left	Thru	Rght	Peds	Left	Thru	Rght	Peds	
06:00	3	78	2	0	1	0	0	0	0	33	0	0	6	0	2	0	125
06:15	3	126	2	0	1	0	1	0	1	37	2	0	4	3	2	0	182
06:30	6	149	2	0	0	0	3	1	0	30	0	0	2	5	0	0	198
06:45	8	196	6	0	1	2	2	0	0	33	1	0	5	2	3	0	259
Total	20	549	12	0	3	2	6	1	1	133	3	0	17	10	7	0	764
07:00	6	139	5	0	2	2	3	0	1	35	1	0	8	3	5	0	210
07:15	8	167	4	0	1	0	2	0	1	55	2	0	10	6	4	0	260
07:30	8	161	7	0	0	1	2	0	0	68	0	0	11	3	2	0	263
07:45	12	168	9	0	0	4	3	0	3	103	2	0	10	8	7	0	329
Total	34	635	25	0	3	7	10	0	5	261	5	0	39	20	18	0	1062
08:00	15	192	5	0	2	2	3	0	3	79	3	0	10	7	7	0	328
08:15	11	194	7	0	0	4	10	0	4	57	4	0	10	10	10	0	321
08:30	10	134	7	0	1	2	6	0	1	69	1	0	6	4	2	0	243
08:45	12	161	3	0	3	1	3	0	0	58	3	0	10	6	2	0	262
Total	48	681	22	0	6	9	22	0	8	263	11	0	36	27	21	0	1154
09:00	22	107	6	0	1	0	9	0	0	61	2	0	3	8	5	0	224
09:15	13	105	2	0	3	2	10	0	2	62	1	0	3	3	3	0	209
*** BREAK ***																	
Total	35	212	8	0	4	2	19	0	2	123	3	0	6	11	8	0	433
*** BREAK ***																	
10:30	8	97	2	0	1	0	11	0	5	81	5	0	3	7	2	0	222
10:45	14	108	4	0	3	0	9	0	4	99	1	0	6	1	1	0	250
Total	22	205	6	0	4	0	20	0	9	180	6	0	9	8	3	0	472
11:00	14	100	4	0	1	7	10	0	4	86	1	0	2	3	5	0	237
11:15	11	100	5	0	3	5	9	0	5	96	4	0	7	2	3	0	250
11:30	13	92	4	0	1	2	15	0	5	99	4	0	3	4	1	0	243
11:45	15	104	6	0	0	6	12	1	5	104	3	0	3	4	1	0	264
Total	53	396	19	0	5	20	46	1	19	385	12	0	15	13	10	0	994
12:00	16	104	6	0	3	2	17	0	5	116	5	0	8	3	8	0	293
12:15	16	129	5	0	4	4	15	2	4	96	1	0	5	1	4	0	286
12:30	25	119	9	0	5	3	12	1	2	121	4	0	4	5	4	0	314
12:45	17	113	11	0	3	2	8	1	5	103	1	0	6	5	7	0	282
Total	74	465	31	0	15	11	52	4	16	436	11	0	23	14	23	0	1175
13:00	13	124	6	0	1	2	15	0	6	109	6	0	2	1	7	0	292
13:15	8	97	7	0	1	3	13	0	5	101	4	0	6	6	3	0	254
*** BREAK ***																	
Total	21	221	13	0	2	5	28	0	11	210	10	0	8	7	10	0	546
*** BREAK ***																	
14:30	14	144	7	0	3	4	18	1	3	141	3	0	3	3	2	0	346
14:45	9	125	5	0	2	2	10	1	5	147	3	0	12	4	11	0	336
Total	23	269	12	0	5	6	28	2	8	288	6	0	15	7	13	0	682
15:00	10	88	5	0	2	5	17	0	5	199	4	0	5	4	4	0	348
15:15	16	109	10	0	2	7	14	0	11	131	3	0	8	7	4	0	322
15:30	20	84	8	2	0	7	18	0	6	191	2	0	4	5	0	0	347
15:45	14	95	9	0	2	4	11	1	2	181	2	0	6	5	5	0	337
Total	60	376	32	2	6	23	60	1	24	702	11	0	23	21	13	0	1354

# Alliant Engineering Inc Minneapolis, MN 55415

Louisiana Ave S at W Lake Street  
Ref,Pt.:  
Alliant Engineering Inc.  
TURN MOVEMENT COUNT

File Name : 26\_Louisiana Ave at Lake St\_010411  
Site Code : 00000026  
Start Date : 1/4/2011  
Page No : 2

### Groups Printed- Unshifted - Bank 1

Start Time	Louisiana Ave S Southbound				W Lake St Westbound				Louisiana Ave S Northbound				W Lake St Eastbound				Int. Total
	Left	Thru	Rght	Peds	Left	Thru	Rght	Peds	Left	Thru	Rght	Peds	Left	Thru	Rght	Peds	
16:00	16	86	5	0	3	2	18	0	7	183	3	0	8	4	9	0	344
16:15	6	51	6	0	1	2	8	0	4	95	0	0	4	4	2	0	183
16:30	3	74	9	1	0	5	12	0	7	210	3	0	3	6	4	1	338
16:45	15	93	3	0	1	7	13	0	8	152	3	0	6	3	5	0	309
Total	40	304	23	1	5	16	51	0	26	640	9	0	21	17	20	1	1174
17:00	13	86	13	0	2	5	19	0	12	181	5	0	6	5	6	0	353
17:15	17	92	14	0	3	2	13	0	9	153	2	0	11	5	3	0	324
17:30	20	88	6	0	2	0	10	1	6	153	6	0	9	7	10	0	318
17:45	9	96	6	1	0	2	11	1	5	124	3	0	5	2	6	0	271
Total	59	362	39	1	7	9	53	2	32	611	16	0	31	19	25	0	1266
Grand Total	489	4675	242	4	65	110	395	11	161	4232	103	0	243	174	171	1	11076
Apprch %	9	86.4	4.5	0.1	11.2	18.9	68	1.9	3.6	94.1	2.3	0	41.3	29.5	29	0.2	
Total %	4.4	42.2	2.2	0	0.6	1	3.6	0.1	1.5	38.2	0.9	0	2.2	1.6	1.5	0	
Unshifted	474	4467	235	4	58	106	381	11	152	4005	95	0	229	168	167	1	10553
% Unshifted	96.9	95.6	97.1	100	89.2	96.4	96.5	100	94.4	94.6	92.2	0	94.2	96.6	97.7	100	95.3
Bank 1	15	208	7	0	7	4	14	0	9	227	8	0	14	6	4	0	523
% Bank 1	3.1	4.4	2.9	0	10.8	3.6	3.5	0	5.6	5.4	7.8	0	5.8	3.4	2.3	0	4.7

# Alliant Engineering Inc Minneapolis, MN 55415

Louisiana Ave S at W Lake Street  
Ref,Pt.:  
Alliant Engineering Inc.  
TURN MOVEMENT COUNT

File Name : 26\_Louisiana Ave at Lake St\_010411  
Site Code : 00000026  
Start Date : 1/4/2011  
Page No : 3

Start Time	Louisiana Ave S Southbound					W Lake St Westbound					Louisiana Ave S Northbound					W Lake St Eastbound					Int. Total
	Left	Thru	Rght	Peds	App. Total	Left	Thru	Rght	Peds	App. Total	Left	Thru	Rght	Peds	App. Total	Left	Thru	Rght	Peds	App. Total	
Peak Hour Analysis From 06:00 to 09:15 - Peak 1 of 1																					
Peak Hour for Entire Intersection Begins at 07:30																					
07:30	8	161	7	0	176	0	1	2	0	3	0	68	0	0	68	11	3	2	0	16	263
07:45	12	168	9	0	189	0	4	3	0	7	3	103	2	0	108	10	8	7	0	25	329
08:00	15	192	5	0	212	2	2	3	0	7	3	79	3	0	85	10	7	7	0	24	328
08:15	11	194	7	0	212	0	4	10	0	14	4	57	4	0	65	10	10	10	0	30	321
Total Volume	46	715	28	0	789	2	11	18	0	31	10	307	9	0	326	41	28	26	0	95	1241
% App. Total	5.8	90.6	3.5	0		6.5	35.5	58.1	0		3.1	94.2	2.8	0		43.2	29.5	27.4	0		
PHF	.767	.921	.778	.000	.930	.250	.688	.450	.000	.554	.625	.745	.563	.000	.755	.932	.700	.650	.000	.792	.943

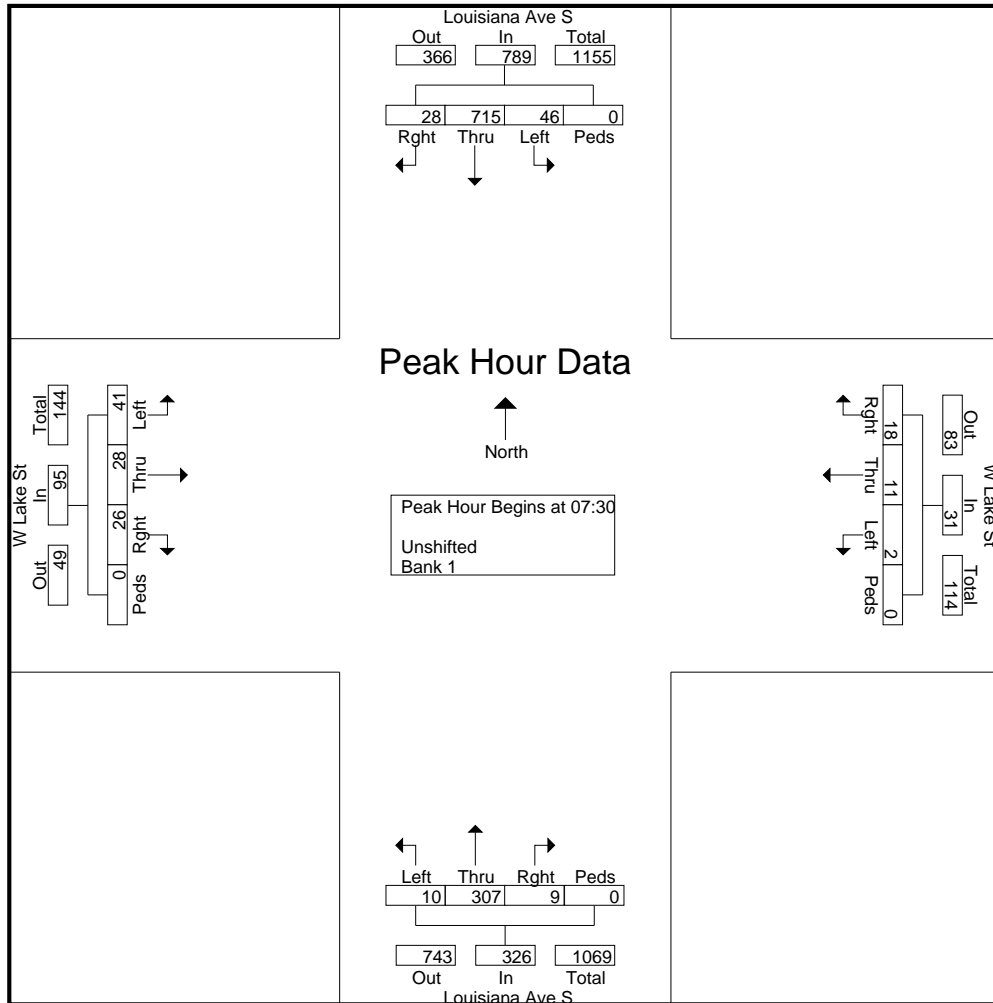

# Alliant Engineering Inc Minneapolis, MN 55415

Louisiana Ave S at W Lake Street  
Ref,Pt.:  
Alliant Engineering Inc.  
TURN MOVEMENT COUNT

File Name : 26\_Louisiana Ave at Lake St\_010411  
Site Code : 00000026  
Start Date : 1/4/2011  
Page No : 4

Start Time	Louisiana Ave S Southbound					W Lake St Westbound					Louisiana Ave S Northbound					W Lake St Eastbound					Int. Total
	Left	Thru	Rght	Peds	App. Total	Left	Thru	Rght	Peds	App. Total	Left	Thru	Rght	Peds	App. Total	Left	Thru	Rght	Peds	App. Total	
Peak Hour Analysis From 14:30 to 17:45 - Peak 1 of 1																					
Peak Hour for Entire Intersection Begins at 15:00																					
15:00	10	88	5	0	103	2	5	17	0	24	5	199	4	0	208	5	4	4	0	13	348
15:15	16	109	10	0	135	2	7	14	0	23	11	131	3	0	145	8	7	4	0	19	322
15:30	20	84	8	2	114	0	7	18	0	25	6	191	2	0	199	4	5	0	0	9	347
15:45	14	95	9	0	118	2	4	11	1	18	2	181	2	0	185	6	5	5	0	16	337
Total Volume	60	376	32	2	470	6	23	60	1	90	24	702	11	0	737	23	21	13	0	57	1354
% App. Total	12.8	80	6.8	0.4		6.7	25.6	66.7	1.1		3.3	95.3	1.5	0		40.4	36.8	22.8	0		
PHF	.750	.862	.800	.250	.870	.750	.821	.833	.250	.900	.545	.882	.688	.000	.886	.719	.750	.650	.000	.750	.973

