



MINNESOTA DEPT OF TRANSPORTATION

TRAFFIC DATA COLLECTION - METRO

TH-77 at Diffley Rd / CSAH-30, E ramps
 Ref.Pt.: 004.707
 JAMAR #D4-3365 CH
 TURN MOVEMENT COUNT

File Name : TH-77 at Diffley Rd Cсах-30 EastRamp 2009
 Site Code : 00000000
 Start Date : 5/12/2009
 Page No : 1

Groups Printed- Cars & Trucks

Start Time	ramp to TH-77 / Cedar Ave NB Southbound				DIFFLEY RD / CSAH-30 Westbound				ramp from TH-77 / Cedar Ave NB Northbound				DIFFLEY RD / CSAH-30 Eastbound				Int. Total
	Left	Thru	Right	Peds	Left	Thru	Right	Peds	Left	Thru	Right	Peds	Left	Thru	Right	Peds	
06:00	0	0	0	0	0	35	88	0	6	0	6	0	6	32	0	0	173
06:15	0	0	0	0	0	32	136	0	3	0	3	0	11	45	0	1	231
06:30	0	0	0	0	0	45	146	0	8	0	4	0	18	49	0	0	270
06:45	0	0	0	0	0	64	178	1	10	0	3	0	13	67	0	1	337
Total	0	0	0	0	0	176	548	1	27	0	16	0	48	193	0	2	1011
07:00	0	0	0	0	0	76	207	0	9	0	5	0	21	79	0	3	400
07:15	0	0	0	0	0	96	217	0	14	0	4	0	28	109	0	2	470
07:30	0	0	0	0	0	88	238	0	6	0	7	0	34	118	0	0	491
07:45	0	0	0	0	0	80	158	0	6	0	0	0	16	88	0	2	350
Total	0	0	0	0	0	340	820	0	35	0	16	0	99	394	0	7	1711
08:00	0	0	0	0	0	59	170	0	9	0	9	0	18	65	0	0	330
08:15	0	0	0	0	0	67	122	1	5	0	10	0	15	69	0	0	289
08:30	0	0	0	0	0	61	116	1	5	1	8	0	7	70	0	1	270
08:45	0	0	0	0	0	57	90	0	8	0	11	0	8	72	0	0	246
Total	0	0	0	0	0	244	498	2	27	1	38	0	48	276	0	1	1135
15:00	0	0	0	0	0	77	42	0	3	0	14	0	6	141	0	1	284
15:15	0	0	0	0	0	71	39	0	10	0	11	0	5	149	0	1	286
15:30	0	0	0	0	0	69	46	0	12	0	11	0	4	170	0	0	312
15:45	0	0	0	0	0	82	41	0	11	0	26	0	8	171	0	1	340
Total	0	0	0	0	0	299	168	0	36	0	62	0	23	631	0	3	1222
16:00	0	0	0	0	0	84	40	0	13	0	16	0	12	183	0	2	350
16:15	0	0	0	0	0	59	55	0	11	0	13	0	0	188	0	4	330
16:30	0	0	0	0	0	80	52	0	11	0	18	0	5	202	0	2	370
16:45	0	0	0	0	0	99	63	0	6	0	15	0	14	233	0	0	430
Total	0	0	0	0	0	322	210	0	41	0	62	0	31	806	0	8	1480
17:00	0	0	0	0	0	78	61	1	11	0	17	0	6	247	0	1	422
17:15	0	0	0	0	0	88	83	0	5	0	24	0	7	269	0	2	478
17:30	0	0	0	0	0	95	53	0	11	0	9	0	3	208	0	1	380
17:45	0	0	0	0	0	92	53	0	8	0	20	0	8	206	0	0	387
Total	0	0	0	0	0	353	250	1	35	0	70	0	24	930	0	4	1667
Grand Total	0	0	0	0	0	1734	2494	4	201	1	264	0	273	3230	0	25	8226
Apprch %	0	0	0	0	0	41	58.9	0.1	43.1	0.2	56.7	0	7.7	91.6	0	0.7	
Total %	0	0	0	0	0	21.1	30.3	0	2.4	0	3.2	0	3.3	39.3	0	0.3	



MINNESOTA DEPT OF TRANSPORTATION

TRAFFIC DATA COLLECTION - METRO

TH-77 at Diffley Rd / CSAH-30, E ramps
 Ref.Pt.: 004.707
 JAMAR #D4-3365 CH
 TURN MOVEMENT COUNT

File Name : TH-77 at Diffley Rd Cсах-30 EastRamp 2009
 Site Code : 00000000
 Start Date : 5/12/2009
 Page No : 2

Start Time	ramp to TH-77 / Cedar Ave NB Southbound					DIFFLEY RD / CSAH-30 Westbound					ramp from TH-77 / Cedar Ave NB Northbound					DIFFLEY RD / CSAH-30 Eastbound					Int. Total
	Left	Thru	Right	Peds	App. Total	Left	Thru	Right	Peds	App. Total	Left	Thru	Right	Peds	App. Total	Left	Thru	Right	Peds	App. Total	
Peak Hour Analysis From 06:00 to 08:45 - Peak 1 of 1																					
Peak Hour for Entire Intersection Begins at 07:00																					
07:00	0	0	0	0	0	0	76	207	0	283	9	0	5	0	14	21	79	0	3	103	400
07:15	0	0	0	0	0	0	96	217	0	313	14	0	4	0	18	28	109	0	2	139	470
07:30	0	0	0	0	0	0	88	238	0	326	6	0	7	0	13	34	118	0	0	152	491
07:45	0	0	0	0	0	0	80	158	0	238	6	0	0	0	6	16	88	0	2	106	350
Total Volume	0	0	0	0	0	0	340	820	0	1160	35	0	16	0	51	99	394	0	7	500	1711
% App. Total	0	0	0	0	0	0	29.3	70.7	0		68.6	0	31.4	0		19.8	78.8	0	1.4		
PHF	.000	.000	.000	.000	.000	.000	.885	.861	.000	.890	.625	.000	.571	.000	.708	.728	.835	.000	.583	.822	.871

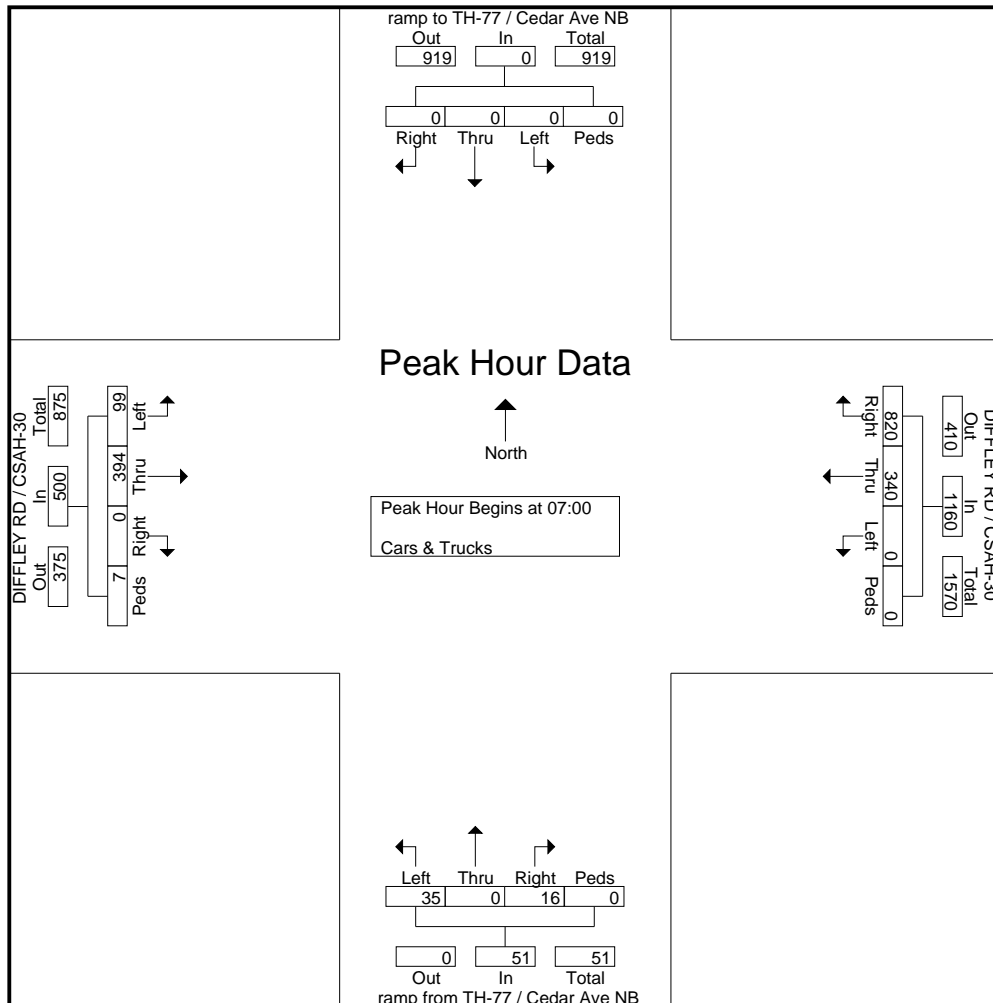



MINNESOTA DEPT OF TRANSPORTATION

TRAFFIC DATA COLLECTION - METRO

TH-77 at Diffley Rd / CSAH-30, E ramps
 Ref.Pt.: 004.707
 JAMAR #D4-3365 CH
 TURN MOVEMENT COUNT

File Name : TH-77 at Diffley Rd Cсах-30 EastRamp 2009
 Site Code : 00000000
 Start Date : 5/12/2009
 Page No : 3

Start Time	ramp to TH-77 / Cedar Ave NB Southbound					DIFFLEY RD / CSAH-30 Westbound					ramp from TH-77 / Cedar Ave NB Northbound					DIFFLEY RD / CSAH-30 Eastbound					Int. Total
	Left	Thru	Right	Peds	App. Total	Left	Thru	Right	Peds	App. Total	Left	Thru	Right	Peds	App. Total	Left	Thru	Right	Peds	App. Total	
Peak Hour Analysis From 15:00 to 17:45 - Peak 1 of 1																					
Peak Hour for Entire Intersection Begins at 16:45																					
16:45	0	0	0	0	0	0	99	63	0	162	6	0	15	0	21	14	233	0	0	247	430
17:00	0	0	0	0	0	0	78	61	1	140	11	0	17	0	28	6	247	0	1	254	422
17:15	0	0	0	0	0	0	88	83	0	171	5	0	24	0	29	7	269	0	2	278	478
17:30	0	0	0	0	0	0	95	53	0	148	11	0	9	0	20	3	208	0	1	212	380
Total Volume	0	0	0	0	0	0	360	260	1	621	33	0	65	0	98	30	957	0	4	991	1710
% App. Total	0	0	0	0	0	0	58	41.9	0.2		33.7	0	66.3	0		3	96.6	0	0.4		
PHF	.000	.000	.000	.000	.000	.000	.909	.783	.250	.908	.750	.000	.677	.000	.845	.536	.889	.000	.500	.891	.894

