

**Alliant Engineering, Inc**

233 Park Ave Suite 300

Minneapolis, MN 55415

--TRAFFIC DATA --

TH-95 at TH-36 S Ramp

Ref.Pt.: Not Available

data by : Alliant Inc.

TURN MOVEMENT COUNT

File Name : 312\_TH 95 & TH 36 S Ramp

Site Code : 312

Start Date : 11/27/2017

Page No : 1

Groups Printed- Vehicles - Trucks

Start Time	TH 95 From North				TH 36 S Ramp From East				TH 95 From South				TH 36 S Ramp From West				Int. Total
	Other	Left	Thru	Rght	Other	Left	Thru	Rght	Other	Left	Thru	Rght	Other	Left	Thru	Rght	
06:00 AM	0	1	77	0	0	0	0	0	0	0	34	7	0	3	0	57	179
06:15 AM	0	7	66	0	0	0	0	0	0	0	68	10	0	3	0	40	194
06:30 AM	0	9	85	0	0	0	0	0	0	0	57	18	0	10	0	55	234
06:45 AM	0	6	87	0	0	0	0	0	0	0	88	19	0	9	0	68	277
Total	0	23	315	0	0	0	0	0	0	0	247	54	0	25	0	220	884
07:00 AM	0	17	67	0	0	0	0	0	0	0	69	11	0	5	0	49	218
07:15 AM	0	8	73	0	0	0	0	0	0	0	119	7	0	6	2	43	258
07:30 AM	0	11	82	0	0	0	0	0	0	0	92	15	0	8	0	65	273
07:45 AM	0	18	73	0	0	0	0	0	0	0	96	15	0	13	2	56	273
Total	0	54	295	0	0	0	0	0	0	0	376	48	0	32	4	213	1022
08:00 AM	0	11	59	0	0	0	0	0	0	0	67	12	0	11	0	43	203
08:15 AM	0	9	52	0	0	0	0	0	0	0	79	5	0	12	0	46	203
08:30 AM	0	13	39	0	0	0	0	0	0	0	105	17	0	19	0	31	224
08:45 AM	0	9	53	0	0	0	0	0	0	0	84	13	0	23	0	53	235
Total	0	42	203	0	0	0	0	0	0	0	335	47	0	65	0	173	865
09:00 AM	0	22	60	0	0	0	0	0	0	0	73	9	0	18	1	33	216
09:15 AM	0	11	56	0	0	0	0	0	0	0	77	10	0	18	0	29	201
*** BREAK ***																	
Total	0	33	116	0	0	0	0	0	0	0	150	19	0	36	1	62	417
*** BREAK ***																	
10:30 AM	0	14	40	0	0	0	0	0	0	0	66	8	0	12	2	37	179
10:45 AM	2	11	32	0	0	0	0	0	0	0	76	4	0	19	2	43	189
Total	2	25	72	0	0	0	0	0	0	0	142	12	0	31	4	80	368
11:00 AM	0	12	34	0	0	0	0	0	0	0	103	8	0	23	0	35	215
11:15 AM	0	5	36	0	0	0	0	0	0	0	93	8	0	26	0	50	218
11:30 AM	0	13	24	0	0	0	0	0	0	0	76	9	0	32	0	59	213
11:45 AM	0	14	40	0	0	0	0	0	0	0	86	14	0	24	0	55	233
Total	0	44	134	0	0	0	0	0	0	0	358	39	0	105	0	199	879
12:00 PM	0	12	26	0	0	0	0	0	0	0	72	4	0	26	0	58	198
12:15 PM	0	12	44	0	0	0	0	0	0	0	59	9	0	34	0	46	204
12:30 PM	0	10	27	0	0	0	0	0	0	0	61	11	0	29	1	65	204
12:45 PM	0	23	35	0	0	0	0	0	0	0	57	5	0	27	0	55	202
Total	0	57	132	0	0	0	0	0	0	0	249	29	0	116	1	224	808
01:00 PM	0	17	38	0	0	0	0	0	0	0	71	11	0	22	0	41	200
01:15 PM	0	20	49	0	0	0	0	0	0	0	78	15	0	25	0	65	252
*** BREAK ***																	
Total	0	37	87	0	0	0	0	0	0	0	149	26	0	47	0	106	452
*** BREAK ***																	
02:30 PM	0	26	39	0	0	0	0	0	0	0	98	52	0	32	0	64	311
02:45 PM	0	16	45	0	0	0	0	0	0	0	202	147	0	17	0	64	491
Total	0	42	84	0	0	0	0	0	0	0	300	199	0	49	0	128	802
03:00 PM	0	36	56	0	0	0	0	0	0	0	137	56	0	21	1	48	355
03:15 PM	0	27	55	0	0	0	0	0	0	0	130	37	0	14	1	47	311
03:30 PM	0	33	41	0	0	0	0	0	0	0	110	52	0	26	1	72	335
03:45 PM	1	30	60	0	0	0	0	0	0	0	135	46	0	45	0	79	396
Total	1	126	212	0	0	0	0	0	0	0	512	191	0	106	3	246	1397
04:00 PM	0	41	51	0	0	0	0	0	0	0	137	58	0	22	0	56	365
04:15 PM	0	35	59	0	0	0	0	0	0	0	140	51	0	46	0	56	387
04:30 PM	0	50	71	0	0	0	0	0	0	0	120	53	0	11	0	69	374
04:45 PM	0	30	48	0	0	0	0	0	0	0	94	46	0	32	1	83	334
Total	0	156	229	0	0	0	0	0	0	0	491	208	0	111	1	264	1460

**Alliant Engineering, Inc**

233 Park Ave Suite 300

Minneapolis, MN 55415

--TRAFFIC DATA --

TH-95 at TH-36 S Ramp  
 Ref.Pt.: Not Available  
 data by : Alliant Inc.  
 TURN MOVEMENT COUNT

File Name : 312\_TH 95 & TH 36 S Ramp  
 Site Code : 312  
 Start Date : 11/27/2017  
 Page No : 2

Groups Printed- Vehicles - Trucks

Start Time	TH 95 From North				TH 36 S Ramp From East				TH 95 From South				TH 36 S Ramp From West				Int. Total
	Other	Left	Thru	Rght	Other	Left	Thru	Rght	Other	Left	Thru	Rght	Other	Left	Thru	Rght	
05:00 PM	0	43	53	0	0	0	0	0	0	0	107	56	0	56	0	100	415
05:15 PM	0	34	52	0	0	0	0	0	0	0	99	49	0	70	0	96	400
05:30 PM	0	31	47	0	0	0	0	0	0	0	97	41	0	32	1	64	313
05:45 PM	0	26	39	0	0	0	0	0	0	0	92	31	0	22	0	50	260
Total	0	134	191	0	0	0	0	0	0	0	395	177	0	180	1	310	1388
Grand Total	3	773	2070	0	0	0	0	0	0	0	3704	1049	0	903	15	2225	10742
Apprch %	0.1	27.2	72.7	0	0	0	0	0	0	0	77.9	22.1	0	28.7	0.5	70.8	
Total %	0	7.2	19.3	0	0	0	0	0	0	0	34.5	9.8	0	8.4	0.1	20.7	
Vehicles	3	758	1996	0	0	0	0	0	0	0	3472	1014	0	858	14	2119	10234
% Vehicles	100	98.1	96.4	0	0	0	0	0	0	0	93.7	96.7	0	95	93.3	95.2	95.3
Trucks	0	15	74	0	0	0	0	0	0	0	232	35	0	45	1	106	508
% Trucks	0	1.9	3.6	0	0	0	0	0	0	0	6.3	3.3	0	5	6.7	4.8	4.7

**Alliant Engineering, Inc**

233 Park Ave Suite 300  
 Minneapolis, MN 55415  
 --TRAFFIC DATA --

TH-95 at TH-36 S Ramp  
 Ref.Pt.: Not Available  
 data by : Alliant Inc.  
 TURN MOVEMENT COUNT

File Name : 312\_TH 95 & TH 36 S Ramp  
 Site Code : 312  
 Start Date : 11/27/2017  
 Page No : 3

Start Time	TH 95 From North					TH 36 S Ramp From East					TH 95 From South					TH 36 S Ramp From West					Int. Total
	Other	Left	Thru	Rght	App. Total	Other	Left	Thru	Rght	App. Total	Other	Left	Thru	Rght	App. Total	Other	Left	Thru	Rght	App. Total	
Peak Hour Analysis From 06:00 AM to 11:45 AM - Peak 1 of 1																					
Peak Hour for Entire Intersection Begins at 06:45 AM																					
06:45 AM	0	6	87	0	93	0	0	0	0	0	0	0	88	19	107	0	9	0	68	77	277
07:00 AM	0	17	67	0	84	0	0	0	0	0	0	0	69	11	80	0	5	0	49	54	218
07:15 AM	0	8	73	0	81	0	0	0	0	0	0	0	119	7	126	0	6	2	43	51	258
07:30 AM	0	11	82	0	93	0	0	0	0	0	0	0	92	15	107	0	8	0	65	73	273
Total Volume	0	42	309	0	351	0	0	0	0	0	0	0	368	52	420	0	28	2	225	255	1026
% App. Total	0	12	88	0		0	0	0	0	0	0	0	87.6	12.4		0	11	0.8	88.2		
PHF	.000	.618	.888	.000	.944	.000	.000	.000	.000	.000	.000	.000	.773	.684	.833	.000	.778	.250	.827	.828	.926

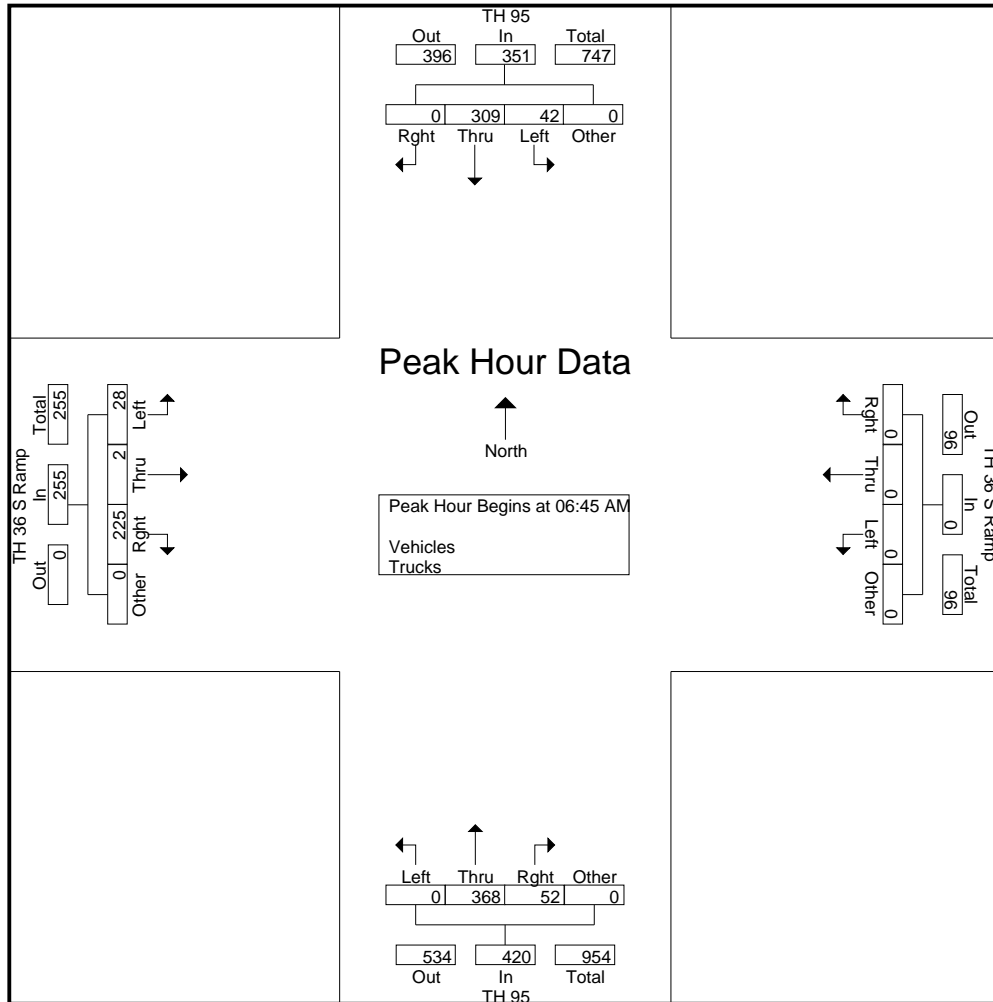

**Alliant Engineering, Inc**

233 Park Ave Suite 300  
 Minneapolis, MN 55415  
 --TRAFFIC DATA --

TH-95 at TH-36 S Ramp  
 Ref.Pt.: Not Available  
 data by : Alliant Inc.  
 TURN MOVEMENT COUNT

File Name : 312\_TH 95 & TH 36 S Ramp  
 Site Code : 312  
 Start Date : 11/27/2017  
 Page No : 4

Start Time	TH 95 From North					TH 36 S Ramp From East					TH 95 From South					TH 36 S Ramp From West					Int. Total
	Other	Left	Thru	Rght	App. Total	Other	Left	Thru	Rght	App. Total	Other	Left	Thru	Rght	App. Total	Other	Left	Thru	Rght	App. Total	
Peak Hour Analysis From 12:00 PM to 05:45 PM - Peak 1 of 1																					
Peak Hour for Entire Intersection Begins at 04:30 PM																					
04:30 PM	0	50	71	0	121	0	0	0	0	0	0	0	120	53	173	0	11	0	69	80	374
04:45 PM	0	30	48	0	78	0	0	0	0	0	0	0	94	46	140	0	32	1	83	116	334
05:00 PM	0	43	53	0	96	0	0	0	0	0	0	0	107	56	163	0	56	0	100	156	415
05:15 PM	0	34	52	0	86	0	0	0	0	0	0	0	99	49	148	0	70	0	96	166	400
Total Volume	0	157	224	0	381	0	0	0	0	0	0	0	420	204	624	0	169	1	348	518	1523
% App. Total	0	41.2	58.8	0		0	0	0	0	0	0	0	67.3	32.7		0	32.6	0.2	67.2		
PHF	.000	.785	.789	.000	.787	.000	.000	.000	.000	.000	.000	.000	.875	.911	.902	.000	.604	.250	.870	.780	.917

