

Alliant Engineering, Inc

233 Park Ave Suite 300
 Minneapolis, MN 55415

--TRAFFIC DATA

TH-95 at Pickett Avenue-King Plant Drive

Ref.Pt.: 106.333

data by : Alliant Inc.

TURN MOVEMENT COUNT

File Name : 313_TH 95 & Pickett Ave-King Plant Dr

Site Code : 313

Start Date : 11/14/2017

Page No : 1

Groups Printed- Vehicles - Trucks

Start Time	TH 95 From North				Pickett Ave/King Plant Dr From East				TH 95 From South				Pickett Ave/King Plant Dr From West				Int. Total
	Other	Left	Thru	Rght	Other	Left	Thru	Rght	Other	Left	Thru	Rght	Other	Left	Thru	Rght	
06:00 AM	0	15	134	21	0	0	0	1	0	2	50	1	0	1	2	7	234
06:15 AM	0	20	51	28	0	0	1	1	0	1	54	6	0	14	0	0	176
06:30 AM	0	9	82	31	0	1	1	1	0	4	90	1	0	6	2	0	228
06:45 AM	0	6	100	42	0	0	2	0	0	9	131	3	0	5	1	1	300
Total	0	50	367	122	0	1	4	3	0	16	325	11	0	26	5	8	938
07:00 AM	0	2	98	17	0	2	1	2	0	8	116	1	0	5	0	5	257
07:15 AM	0	2	123	11	0	0	2	2	0	8	121	0	0	1	0	6	276
07:30 AM	0	2	157	14	0	2	0	0	0	6	94	1	0	2	0	3	281
07:45 AM	0	2	144	23	0	1	0	1	0	12	108	1	0	4	0	3	299
Total	0	8	522	65	0	5	3	5	0	34	439	3	0	12	0	17	1113
08:00 AM	0	6	99	12	0	0	1	1	0	4	91	0	0	1	0	5	220
08:15 AM	0	1	94	10	0	1	0	2	0	4	95	1	0	1	1	4	214
08:30 AM	0	1	67	15	0	0	0	0	0	4	108	2	0	3	1	5	206
08:45 AM	0	2	82	17	0	3	0	1	0	3	100	1	0	1	0	2	212
Total	0	10	342	54	0	4	1	4	0	15	394	4	0	6	2	16	852
09:00 AM	0	3	58	18	0	2	0	0	0	1	69	1	0	1	0	10	163
09:15 AM	0	1	68	19	0	2	1	2	0	3	79	1	0	2	1	3	182
*** BREAK ***																	
Total	0	4	126	37	0	4	1	2	0	4	148	2	0	3	1	13	345
*** BREAK ***																	
10:30 AM	0	2	57	9	0	0	0	1	1	2	76	2	0	2	0	3	155
10:45 AM	0	2	74	9	0	4	0	2	0	0	64	1	0	0	3	2	161
Total	0	4	131	18	0	4	0	3	1	2	140	3	0	2	3	5	316
11:00 AM	1	1	86	7	0	2	0	2	0	2	90	1	0	1	1	5	199
11:15 AM	0	1	73	12	0	0	2	1	0	5	79	0	0	3	1	1	178
11:30 AM	0	3	91	9	0	0	0	5	0	7	88	0	0	1	0	4	208
11:45 AM	1	6	88	6	0	1	1	2	1	7	85	1	0	1	2	6	208
Total	2	11	338	34	0	3	3	10	1	21	342	2	0	6	4	16	793
12:00 PM	0	1	90	11	0	2	1	0	0	2	79	0	0	1	0	3	190
12:15 PM	0	1	62	5	0	1	0	3	0	1	68	1	0	1	0	11	154
12:30 PM	0	1	72	12	0	1	2	1	0	7	73	0	0	0	0	5	174
12:45 PM	0	6	86	6	0	0	0	0	0	4	79	2	0	1	1	7	192
Total	0	9	310	34	0	4	3	4	0	14	299	3	0	3	1	26	710
01:00 PM	0	5	75	11	0	2	2	2	0	2	77	0	0	0	1	0	177
01:15 PM	0	3	88	16	0	1	2	1	0	3	60	2	0	0	0	6	182
*** BREAK ***																	
Total	0	8	163	27	0	3	4	3	0	5	137	2	0	0	1	6	359
*** BREAK ***																	
02:30 PM	0	6	96	5	0	3	1	12	0	1	157	1	0	0	0	2	284
02:45 PM	0	3	94	4	0	2	3	19	0	14	314	1	0	0	0	4	458
Total	0	9	190	9	0	5	4	31	0	15	471	2	0	0	0	6	742
03:00 PM	0	0	77	6	0	5	2	8	0	8	152	0	0	2	0	4	264
03:15 PM	0	1	85	5	0	1	0	6	0	3	158	0	0	2	0	2	263
03:30 PM	0	0	104	13	0	0	1	4	0	4	164	0	0	1	0	11	302
03:45 PM	0	0	107	16	0	3	0	1	0	1	156	0	0	0	1	5	290
Total	0	1	373	40	0	9	3	19	0	16	630	0	0	5	1	22	1119
04:00 PM	0	1	121	8	0	1	0	0	0	2	135	1	0	1	0	5	275
04:15 PM	0	0	128	15	0	0	2	6	0	4	150	1	0	1	0	10	317
04:30 PM	0	0	118	14	0	1	1	3	0	4	138	0	0	1	0	14	294
04:45 PM	0	1	128	12	0	4	0	6	0	1	143	1	0	1	0	8	305
Total	0	2	495	49	0	6	3	15	0	11	566	3	0	4	0	37	1191

Alliant Engineering, Inc

233 Park Ave Suite 300

Minneapolis, MN 55415

--TRAFFIC DATA

TH-95 at Pickett Avenue-King Plant Drive

Ref.Pt.: 106.333

data by : Alliant Inc.

TURN MOVEMENT COUNT

File Name : 313_TH 95 & Pickett Ave-King Plant Dr

Site Code : 313

Start Date : 11/14/2017

Page No : 2

Groups Printed- Vehicles - Trucks

Start Time	TH 95 From North				Pickett Ave/King Plant Dr From East				TH 95 From South				Pickett Ave/King Plant Dr From West				Int. Total
	Other	Left	Thru	Rght	Other	Left	Thru	Rght	Other	Left	Thru	Rght	Other	Left	Thru	Rght	
05:00 PM	0	0	143	11	0	0	1	1	0	2	133	0	0	1	0	10	302
05:15 PM	0	0	120	17	0	0	0	2	0	1	118	0	0	0	0	2	260
05:30 PM	0	0	80	16	0	0	0	0	0	3	134	0	0	0	0	4	237
05:45 PM	0	0	104	11	0	0	0	0	0	1	103	0	0	0	1	1	221
Total	0	0	447	55	0	0	1	3	0	7	488	0	0	1	1	17	1020
Grand Total	2	116	3804	544	0	48	30	102	2	160	4379	35	0	68	19	189	9498
Apprch %	0	2.6	85.2	12.2	0	26.7	16.7	56.7	0	3.5	95.7	0.8	0	24.6	6.9	68.5	
Total %	0	1.2	40.1	5.7	0	0.5	0.3	1.1	0	1.7	46.1	0.4	0	0.7	0.2	2	
Vehicles	1	107	3716	484	0	34	23	99	2	156	4279	30	0	4	17	184	9136
% Vehicles	50	92.2	97.7	89	0	70.8	76.7	97.1	100	97.5	97.7	85.7	0	5.9	89.5	97.4	96.2
Trucks	1	9	88	60	0	14	7	3	0	4	100	5	0	64	2	5	362
% Trucks	50	7.8	2.3	11	0	29.2	23.3	2.9	0	2.5	2.3	14.3	0	94.1	10.5	2.6	3.8

Alliant Engineering, Inc

233 Park Ave Suite 300
 Minneapolis, MN 55415

--TRAFFIC DATA

TH-95 at Pickett Avenue-King Plant Drive
 Ref.Pt.: 106.333
 data by : Alliant Inc.
 TURN MOVEMENT COUNT

File Name : 313_TH 95 & Pickett Ave-King Plant Dr
 Site Code : 313
 Start Date : 11/14/2017
 Page No : 3

Start Time	TH 95 From North					Pickett Ave/King Plant Dr From East					TH 95 From South					Pickett Ave/King Plant Dr From West					Int. Total
	Other	Left	Thru	Right	App. Total	Other	Left	Thru	Right	App. Total	Other	Left	Thru	Right	App. Total	Other	Left	Thru	Right	App. Total	
Peak Hour Analysis From 06:00 AM to 11:45 AM - Peak 1 of 1																					
Peak Hour for Entire Intersection Begins at 06:45 AM																					
06:45 AM	0	6	100	42	148	0	0	2	0	2	0	9	131	3	143	0	5	1	1	7	300
07:00 AM	0	2	98	17	117	0	2	1	2	5	0	8	116	1	125	0	5	0	5	10	257
07:15 AM	0	2	123	11	136	0	0	2	2	4	0	8	121	0	129	0	1	0	6	7	276
07:30 AM	0	2	157	14	173	0	2	0	0	2	0	6	94	1	101	0	2	0	3	5	281
Total Volume	0	12	478	84	574	0	4	5	4	13	0	31	462	5	498	0	13	1	15	29	1114
% App. Total	0	2.1	83.3	14.6		0	30.8	38.5	30.8		0	6.2	92.8	1		0	44.8	3.4	51.7		
PHF	.000	.500	.761	.500	.829	.000	.500	.625	.500	.650	.000	.861	.882	.417	.871	.000	.650	.250	.625	.725	.928

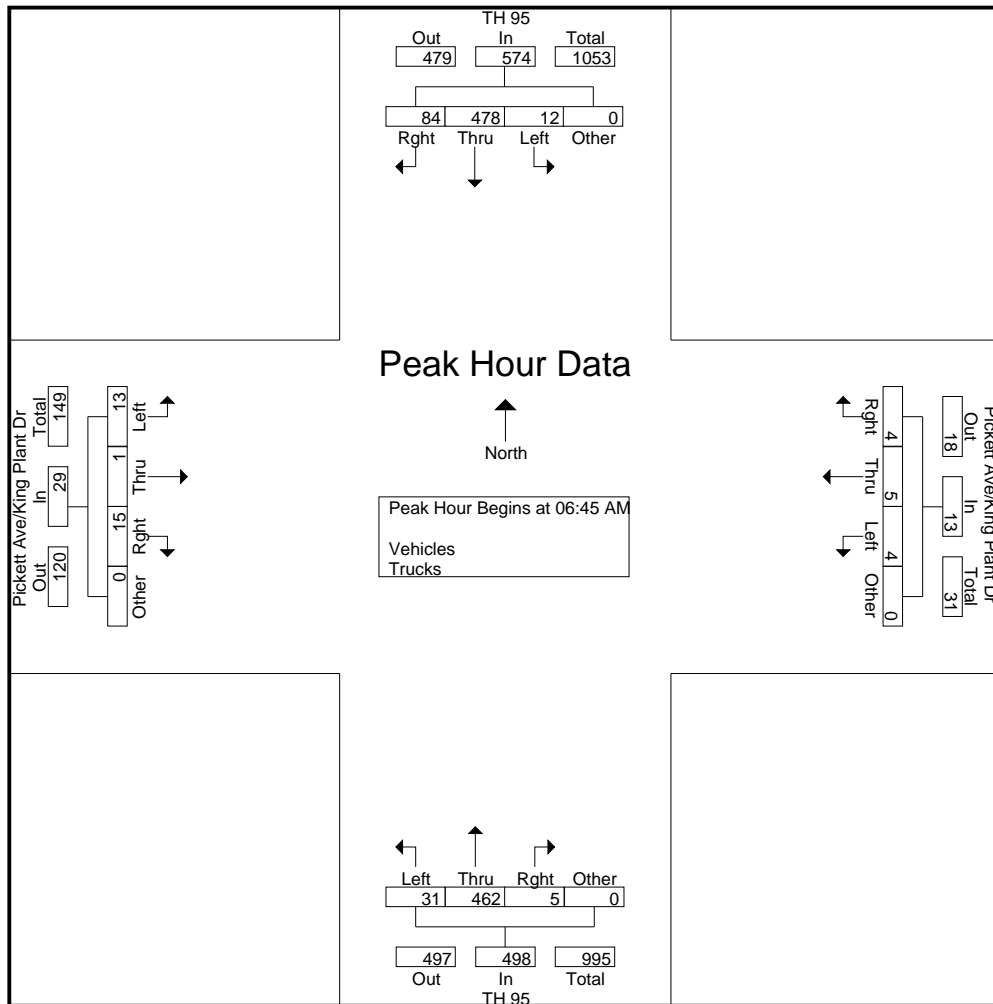

Alliant Engineering, Inc

233 Park Ave Suite 300
 Minneapolis, MN 55415
 --TRAFFIC DATA

TH-95 at Pickett Avenue-King Plant Drive
 Ref.Pt.: 106.333
 data by : Alliant Inc.
 TURN MOVEMENT COUNT

File Name : 313_TH 95 & Pickett Ave-King Plant Dr
 Site Code : 313
 Start Date : 11/14/2017
 Page No : 4

Start Time	TH 95 From North					Pickett Ave/King Plant Dr From East					TH 95 From South					Pickett Ave/King Plant Dr From West					Int. Total
	Other	Left	Thru	Rght	App. Total	Other	Left	Thru	Rght	App. Total	Other	Left	Thru	Rght	App. Total	Other	Left	Thru	Rght	App. Total	
Peak Hour Analysis From 12:00 PM to 05:45 PM - Peak 1 of 1																					
Peak Hour for Entire Intersection Begins at 02:45 PM																					
02:45 PM	0	3	94	4	101	0	2	3	19	24	0	14	314	1	329	0	0	0	4	4	458
03:00 PM	0	0	77	6	83	0	5	2	8	15	0	8	152	0	160	0	2	0	4	6	264
03:15 PM	0	1	85	5	91	0	1	0	6	7	0	3	158	0	161	0	2	0	2	4	263
03:30 PM	0	0	104	13	117	0	0	1	4	5	0	4	164	0	168	0	1	0	11	12	302
Total Volume	0	4	360	28	392	0	8	6	37	51	0	29	788	1	818	0	5	0	21	26	1287
% App. Total	0	1	91.8	7.1		0	15.7	11.8	72.5		0	3.5	96.3	0.1		0	19.2	0	80.8		
PHF	.000	.333	.865	.538	.838	.000	.400	.500	.487	.531	.000	.518	.627	.250	.622	.000	.625	.000	.477	.542	.703

