

Albeck Gerken, Inc

Transportation Engineers

Traffic Data Collection

80th St E at Blaine Ave (east of TH-52)

Inver Grove Heights

Ref.Pt.: 122.516

TURN MOVEMENT COUNTS

File Name : 41 80th St & Blaine Ave

Site Code : 41

Start Date : 1/13/2012

Page No : 1

Groups Printed- Cars - Heavy Vehicles

Start Time	Blaine Ave E Southbound				80th St E Westbound				Blaine Ave E Northbound				80th St E Eastbound				Int. Total
	Left	Thru	Right	Peds	Left	Thru	Right	Peds	Left	Thru	Right	Peds	Left	Thru	Right	Peds	
06:00	0	0	4	0	3	71	0	0	3	0	2	0	4	14	1	0	102
06:15	0	0	12	1	1	79	2	0	3	0	0	0	0	16	5	0	119
06:30	3	1	18	2	4	88	2	0	7	2	1	0	3	38	4	0	173
06:45	20	0	12	0	0	98	3	1	9	0	5	1	5	62	11	0	227
Total	23	1	46	3	8	336	7	1	22	2	8	1	12	130	21	0	621
07:00	51	1	10	0	4	115	5	0	9	2	11	0	4	93	12	0	317
07:15	40	1	21	0	2	118	12	0	9	0	4	0	7	82	30	0	326
07:30	24	3	22	0	6	95	9	0	11	1	7	1	7	62	47	0	295
07:45	6	12	16	0	8	87	2	0	11	1	1	1	5	46	107	2	305
Total	121	17	69	0	20	415	28	0	40	4	23	2	23	283	196	2	1243
08:00	5	3	11	1	9	85	7	0	9	0	4	0	5	42	29	0	210
08:15	5	2	7	0	3	73	1	0	7	0	1	0	4	32	29	0	164
08:30	5	1	10	0	12	71	3	0	10	0	4	0	7	35	63	0	221
08:45	5	7	14	0	18	59	2	1	23	5	2	0	4	39	108	1	288
Total	20	13	42	1	42	288	13	1	49	5	11	0	20	148	229	1	883
09:00	6	2	7	0	8	51	4	0	19	1	6	0	3	22	33	0	162
09:15	6	1	5	1	8	37	1	0	11	1	2	0	10	21	32	0	136
09:30	1	6	6	0	5	52	2	0	14	1	0	0	3	47	47	0	184
09:45	5	6	10	1	10	49	6	0	34	2	9	0	6	40	63	0	241
Total	18	15	28	2	31	189	13	0	78	5	17	0	22	130	175	0	723
10:00	4	1	6	0	5	55	6	0	29	3	6	0	11	45	35	0	206
10:15	8	3	4	0	9	40	5	0	17	4	5	1	5	37	39	1	178
10:30	9	3	3	0	6	45	4	0	25	1	6	0	5	38	30	0	175
10:45	5	6	9	0	14	32	4	0	37	3	9	0	3	44	44	0	210
Total	26	13	22	0	34	172	19	0	108	11	26	1	24	164	148	1	769
11:00	9	2	10	0	5	41	5	0	32	5	6	0	2	31	21	0	169
11:15	7	1	5	0	11	45	2	0	22	4	5	0	9	50	21	0	182
11:30	5	8	8	0	5	35	6	1	43	7	12	0	6	48	33	0	217
11:45	3	7	4	0	12	52	6	1	64	4	16	0	7	39	45	0	260
Total	24	18	27	0	33	173	19	2	161	20	39	0	24	168	120	0	828
12:00	9	2	5	0	12	60	3	0	36	4	15	0	15	43	26	0	230
12:15	2	9	6	0	7	70	7	0	19	2	7	1	7	39	13	0	189
12:30	6	8	5	0	5	54	2	0	27	2	7	0	4	45	20	0	185
12:45	4	5	8	0	10	55	4	0	54	11	10	0	5	33	36	0	235
Total	21	24	24	0	34	239	16	0	136	19	39	1	31	160	95	0	839
13:00	2	2	4	0	8	45	2	0	35	7	13	0	10	57	29	0	214
13:15	5	6	9	1	14	50	4	0	53	8	13	0	6	39	35	0	243
13:30	12	5	11	0	9	52	7	2	49	3	7	0	4	49	38	0	248
13:45	5	5	3	0	13	39	3	1	44	4	11	0	12	63	40	0	243
Total	24	18	27	1	44	186	16	3	181	22	44	0	32	208	142	0	948
14:00	5	2	10	2	6	47	3	1	29	5	10	0	5	51	18	0	194
14:15	6	2	6	0	7	49	9	0	29	2	14	0	6	70	24	0	224
14:30	15	6	2	0	11	102	33	0	39	5	4	0	8	78	18	0	321
14:45	10	3	4	0	10	72	6	4	40	5	10	0	7	72	37	0	280
Total	36	13	22	2	34	270	51	5	137	17	38	0	26	271	97	0	1019
15:00	6	0	7	1	8	78	7	0	38	4	15	1	8	74	10	0	257
15:15	5	1	1	0	8	58	6	1	71	8	12	0	10	82	22	0	285
15:30	11	5	8	1	6	66	13	0	50	6	10	0	11	90	26	0	303
15:45	11	4	12	1	5	63	13	1	32	4	11	2	17	85	18	0	279
Total	33	10	28	3	27	265	39	2	191	22	48	3	46	331	76	0	1124

Albeck Gerken, Inc

Transportation Engineers

Traffic Data Collection

80th St E at Blaine Ave (east of TH-52)

Inver Grove Heights

Ref.Pt.: 122.516

TURN MOVEMENT COUNTS

File Name : 41 80th St & Blaine Ave

Site Code : 41

Start Date : 1/13/2012

Page No : 2

Groups Printed- Cars - Heavy Vehicles

Start Time	Blaine Ave E Southbound				80th St E Westbound				Blaine Ave E Northbound				80th St E Eastbound				Int. Total
	Left	Thru	Right	Peds	Left	Thru	Right	Peds	Left	Thru	Right	Peds	Left	Thru	Right	Peds	
16:00	16	6	9	0	7	73	13	0	32	5	9	2	15	117	26	0	330
16:15	12	3	10	0	9	72	11	4	38	6	15	4	17	138	19	0	358
16:30	21	2	12	2	8	73	9	3	55	7	19	0	19	116	25	1	372
16:45	11	1	8	1	13	56	9	1	26	4	9	3	16	129	30	0	317
Total	60	12	39	3	37	274	42	8	151	22	52	9	67	500	100	1	1377
17:00	21	5	15	1	13	57	14	0	23	3	9	2	12	113	32	0	320
17:15	13	3	15	0	11	84	12	4	30	8	11	0	25	122	42	0	380
17:30	3	4	9	1	19	71	17	2	22	3	11	0	11	109	43	0	325
17:45	10	11	12	1	21	87	11	0	31	4	7	0	11	104	72	0	382
Total	47	23	51	3	64	299	54	6	106	18	38	2	59	448	189	0	1407
18:00	17	5	9	0	7	65	15	1	13	3	7	2	18	96	23	0	281
18:15	12	1	13	0	2	64	6	3	26	2	6	1	11	78	7	0	232
18:30	12	4	6	2	9	60	9	1	19	4	11	3	7	66	13	0	226
18:45	12	0	11	1	5	77	18	1	17	3	4	2	12	59	3	0	225
Total	53	10	39	3	23	266	48	6	75	12	28	8	48	299	46	0	964
Grand Total	506	187	464	21	431	3372	365	34	1435	179	411	27	434	3240	1634	5	12745
Apprch %	43	15.9	39.4	1.8	10.3	80.2	8.7	0.8	69.9	8.7	20	1.3	8.2	61	30.8	0.1	
Total %	4	1.5	3.6	0.2	3.4	26.5	2.9	0.3	11.3	1.4	3.2	0.2	3.4	25.4	12.8	0	
Cars	495	183	458	15	400	3280	357	26	1401	175	378	24	427	3163	1615	2	12399
% Cars	97.8	97.9	98.7	71.4	92.8	97.3	97.8	76.5	97.6	97.8	92	88.9	98.4	97.6	98.8	40	97.3
Heavy Vehicles	11	4	6	6	31	92	8	8	34	4	33	3	7	77	19	3	346
% Heavy Vehicles	2.2	2.1	1.3	28.6	7.2	2.7	2.2	23.5	2.4	2.2	8	11.1	1.6	2.4	1.2	60	2.7

Albeck Gerken, Inc

Transportation Engineers

Traffic Data Collection

80th St E at Blaine Ave (east of TH-52)

Inver Grove Heights

Ref.Pt.: 122.516

TURN MOVEMENT COUNTS

File Name : 41 80th St & Blaine Ave

Site Code : 41

Start Date : 1/13/2012

Page No : 3

Start Time	Blaine Ave E Southbound					80th St E Westbound					Blaine Ave E Northbound					80th St E Eastbound					Int. Total
	Left	Thru	Right	Peds	App. Total	Left	Thru	Right	Peds	App. Total	Left	Thru	Right	Peds	App. Total	Left	Thru	Right	Peds	App. Total	
Peak Hour Analysis From 06:00 to 08:45 - Peak 1 of 1																					
Peak Hour for Entire Intersection Begins at 07:00																					
07:00	51	1	10	0	62	4	115	5	0	124	9	2	11	0	22	4	93	12	0	109	317
07:15	40	1	21	0	62	2	118	12	0	132	9	0	4	0	13	7	82	30	0	119	326
07:30	24	3	22	0	49	6	95	9	0	110	11	1	7	1	20	7	62	47	0	116	295
07:45	6	12	16	0	34	8	87	2	0	97	11	1	1	1	14	5	46	107	2	160	305
Total Volume	121	17	69	0	207	20	415	28	0	463	40	4	23	2	69	23	283	196	2	504	1243
% App. Total	58.5	8.2	33.3	0		4.3	89.6	6	0		58	5.8	33.3	2.9		4.6	56.2	38.9	0.4		
PHF	.593	.354	.784	.000	.835	.625	.879	.583	.000	.877	.909	.500	.523	.500	.784	.821	.761	.458	.250	.788	.953

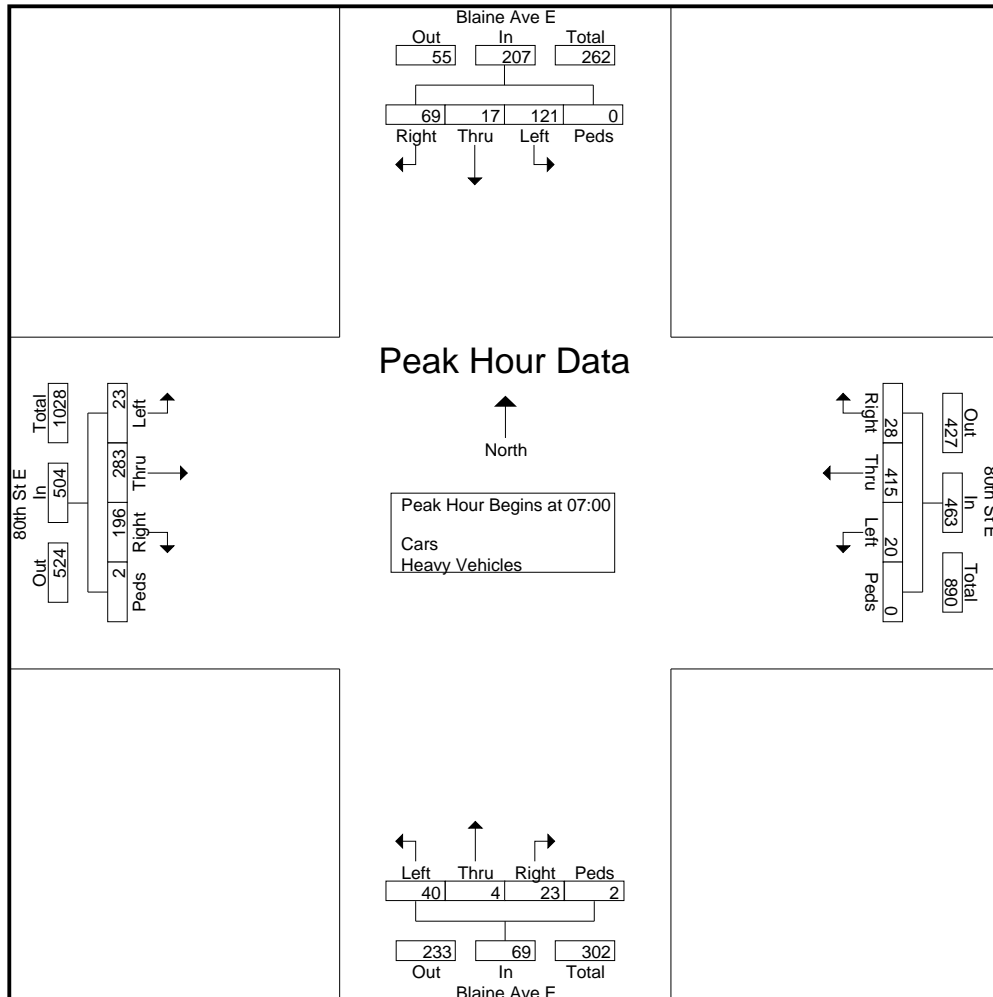

Albeck Gerken, Inc

Transportation Engineers

Traffic Data Collection

80th St E at Blaine Ave (east of TH-52)

Inver Grove Heights

Ref.Pt.: 122.516

TURN MOVEMENT COUNTS

File Name : 41 80th St & Blaine Ave

Site Code : 41

Start Date : 1/13/2012

Page No : 4

Start Time	Blaine Ave E Southbound					80th St E Westbound					Blaine Ave E Northbound					80th St E Eastbound					Int. Total
	Left	Thru	Right	Peds	App. Total	Left	Thru	Right	Peds	App. Total	Left	Thru	Right	Peds	App. Total	Left	Thru	Right	Peds	App. Total	
Peak Hour Analysis From 15:00 to 18:45 - Peak 1 of 1																					
Peak Hour for Entire Intersection Begins at 17:00																					
17:00	21	5	15	1	42	13	57	14	0	84	23	3	9	2	37	12	113	32	0	157	320
17:15	13	3	15	0	31	11	84	12	4	111	30	8	11	0	49	25	122	42	0	189	380
17:30	3	4	9	1	17	19	71	17	2	109	22	3	11	0	36	11	109	43	0	163	325
17:45	10	11	12	1	34	21	87	11	0	119	31	4	7	0	42	11	104	72	0	187	382
Total Volume	47	23	51	3	124	64	299	54	6	423	106	18	38	2	164	59	448	189	0	696	1407
% App. Total	37.9	18.5	41.1	2.4		15.1	70.7	12.8	1.4		64.6	11	23.2	1.2		8.5	64.4	27.2	0		
PHF	.560	.523	.850	.750	.738	.762	.859	.794	.375	.889	.855	.563	.864	.250	.837	.590	.918	.656	.000	.921	.921

