

# Short Elliott Hendrickson Inc.

3535 Vadnais Center Drive  
St. Paul, MN 55110

"Building a Better World for All of Us"



## TRAFFIC DATA

TH 52 & 80th St E Ramp

Ref.Pt.: 122.490

Data By: Short Elliott Hendrickson, Inc.

TURN MOVEMENT COUNT

File Name : TH 52 & 80th St E Ramp 2019

Site Code : 2b

Start Date : 4/23/2019

Page No : 1

### Groups Printed- Vehicles - Trucks

Start Time	TH 52 Northbound Ramp Southbound					80th St Westbound					Broderick Blvd Northbound					80th St Eastbound					Int. Total
	Left	Thru	Right	Peds	App. Total	Left	Thru	Right	Peds	App. Total	Left	Thru	Right	Peds	App. Total	Left	Thru	Right	Peds	App. Total	
06:00	0	0	0	1	1	0	40	29	0	69	2	8	0	0	10	36	27	2	0	65	145
06:15	3	0	0	0	3	1	37	40	0	78	3	11	0	1	15	46	24	4	0	74	170
06:30	2	1	1	0	4	0	65	40	0	105	2	15	1	0	18	80	31	5	0	116	243
06:45	2	0	0	0	2	1	66	62	0	129	4	17	2	0	23	83	64	13	0	160	314
Total	7	1	1	1	10	2	208	171	0	381	11	51	3	1	66	245	146	24	0	415	872
07:00	13	0	2	0	15	0	44	77	0	121	2	25	0	0	27	92	87	6	0	185	348
07:15	7	1	1	0	9	1	54	101	0	156	8	30	4	2	44	114	124	18	0	256	465
07:30	18	2	0	1	21	0	67	91	0	158	4	28	8	0	40	129	114	18	0	261	480
07:45	19	5	6	0	30	0	71	61	0	132	9	19	1	0	29	118	100	42	0	260	451
Total	57	8	9	1	75	1	236	330	0	567	23	102	13	2	140	453	425	84	0	962	1744
08:00	4	2	7	0	13	1	53	51	0	105	4	24	0	0	28	91	86	24	0	201	347
08:15	8	1	5	0	14	2	44	53	0	99	5	12	1	0	18	68	57	11	0	136	267
08:30	7	2	0	0	9	1	53	37	0	91	11	18	3	0	32	90	64	12	0	166	298
08:45	3	3	2	0	8	0	41	31	0	72	5	10	1	0	16	37	69	18	0	124	220
Total	22	8	14	0	44	4	191	172	0	367	25	64	5	0	94	286	276	65	0	627	1132
09:00	12	3	3	0	18	2	28	26	0	56	5	11	1	1	18	85	79	23	0	187	279
09:15	15	7	1	0	23	1	37	46	0	84	8	17	3	0	28	77	94	44	0	215	350
09:30	11	5	1	0	17	3	40	27	0	70	4	12	2	0	18	43	69	22	0	134	239
09:45	16	7	3	0	26	4	48	37	0	89	9	13	2	0	24	38	106	57	0	201	340
Total	54	22	8	0	84	10	153	136	0	299	26	53	8	1	88	243	348	146	0	737	1208
10:00	2	1	0	0	3	2	34	33	0	69	6	7	2	0	15	42	66	22	0	130	217
10:15	5	3	3	0	11	2	37	38	0	77	3	7	2	0	12	51	71	13	0	135	235
10:30	8	2	1	0	11	0	45	30	0	75	6	13	2	0	21	44	77	20	0	141	248
10:45	12	4	2	0	18	6	49	36	0	91	7	12	4	0	23	41	82	27	0	150	282
Total	27	10	6	0	43	10	165	137	0	312	22	39	10	0	71	178	296	82	0	556	982
11:00	7	2	3	0	12	0	26	34	0	60	6	10	3	0	19	35	68	25	0	128	219
11:15	6	1	1	0	8	4	49	37	0	90	15	24	5	0	44	31	63	13	0	107	249
11:30	6	1	1	0	8	1	39	44	0	84	15	12	6	0	33	42	95	25	0	162	287
11:45	10	2	1	0	13	0	46	44	0	90	14	16	7	2	39	34	95	32	0	161	303
Total	29	6	6	0	41	5	160	159	0	324	50	62	21	2	135	142	321	95	0	558	1058
12:00	4	1	2	0	7	3	37	40	0	80	13	15	2	1	31	51	103	22	0	176	294
12:15	7	1	1	0	9	2	69	55	0	126	11	18	6	0	35	32	98	26	0	156	326
12:30	4	2	2	0	8	2	48	50	0	100	7	14	2	0	23	40	74	13	0	127	258
12:45	4	0	1	0	5	3	45	43	0	91	12	10	5	0	27	38	70	16	0	124	247
Total	19	4	6	0	29	10	199	188	0	397	43	57	15	1	116	161	345	77	0	583	1125
13:00	6	0	3	0	9	2	48	38	0	88	9	20	4	0	33	30	62	11	0	103	233
13:15	2	0	0	0	2	5	50	25	0	80	11	14	6	0	31	40	71	17	0	128	241
13:30	3	0	1	0	4	1	59	50	0	110	15	20	4	0	39	35	76	9	0	120	273
13:45	6	0	4	0	10	2	72	75	0	149	36	32	8	0	76	53	100	21	0	174	409
Total	17	0	8	0	25	10	229	188	0	427	71	86	22	0	179	158	309	58	0	525	1156

# Short Elliott Hendrickson Inc.

3535 Vadnais Center Drive  
St. Paul, MN 55110

"Building a Better World for All of Us"



## TRAFFIC DATA

TH 52 & 80th St E Ramp

Ref.Pt.: 122.490

Data By: Short Elliott Hendrickson, Inc.

TURN MOVEMENT COUNT

File Name : TH 52 & 80th St E Ramp 2019

Site Code : 2b

Start Date : 4/23/2019

Page No : 2

Groups Printed- Vehicles - Trucks

Start Time	TH 52 Northbound Ramp Southbound					80th St Westbound					Broderick Blvd Northbound					80th St Eastbound					Int. Total
	Left	Thru	Right	Peds	App. Total	Left	Thru	Right	Peds	App. Total	Left	Thru	Right	Peds	App. Total	Left	Thru	Right	Peds	App. Total	
14:00	4	1	3	0	8	3	60	55	0	118	12	12	4	1	29	49	82	16	0	147	302
14:15	5	0	2	0	7	0	48	39	0	87	7	14	2	0	23	56	104	19	0	179	296
14:30	2	1	5	2	10	4	76	80	0	160	6	15	3	0	24	69	108	23	0	200	394
14:45	4	0	1	6	11	3	56	50	0	109	8	14	2	0	24	63	105	30	0	198	342
Total	15	2	11	8	36	10	240	224	0	474	33	55	11	1	100	237	399	88	0	724	1334
15:00	3	0	0	0	3	2	61	51	2	116	9	12	3	0	24	64	120	20	0	204	347
15:15	4	0	5	1	10	2	62	40	0	104	5	9	6	1	21	63	141	28	0	232	367
15:30	7	0	1	0	8	1	54	44	0	99	5	12	7	0	24	71	140	10	0	221	352
15:45	5	0	2	1	8	3	69	38	0	110	7	15	8	1	31	75	150	21	0	246	395
Total	19	0	8	2	29	8	246	173	2	429	26	48	24	2	100	273	551	79	0	903	1461
16:00	7	0	1	1	9	1	64	55	0	120	15	16	2	2	35	77	149	15	0	241	405
16:15	6	0	0	0	6	0	58	39	0	97	3	18	5	1	27	114	154	21	0	289	419
16:30	15	1	3	2	21	2	57	48	2	109	12	20	5	0	37	105	174	25	0	304	471
16:45	9	1	6	0	16	1	80	36	0	117	13	15	4	0	32	96	202	29	0	327	492
Total	37	2	10	3	52	4	259	178	2	443	43	69	16	3	131	392	679	90	0	1161	1787
17:00	7	1	2	0	10	1	72	38	0	111	5	10	1	0	16	109	177	26	0	312	449
17:15	7	1	6	0	14	2	65	31	0	98	8	11	5	0	24	96	189	33	0	318	454
17:30	12	0	2	0	14	1	75	42	0	118	8	10	4	2	24	72	187	20	0	279	435
17:45	14	1	2	0	17	4	81	72	0	157	7	9	2	0	18	73	172	29	0	274	466
Total	40	3	12	0	55	8	293	183	0	484	28	40	12	2	82	350	725	108	0	1183	1804
18:00	6	0	2	0	8	2	75	58	0	135	2	10	4	2	18	81	153	33	0	267	428
18:15	8	0	3	0	11	1	80	51	0	132	7	12	7	0	26	74	116	13	0	203	372
18:30	3	0	1	2	6	6	61	54	0	121	3	7	3	1	14	60	112	20	0	192	333
18:45	4	1	2	2	9	4	40	41	0	85	6	6	1	0	13	75	132	20	0	227	334
Total	21	1	8	4	34	13	256	204	0	473	18	35	15	3	71	290	513	86	0	889	1467
Grand Total	364	67	107	19	557	95	2835	2443	4	5377	419	761	175	18	1373	3408	5333	1082	0	9823	17130
Apprch %	65.4	12	19.2	3.4		1.8	52.7	45.4	0.1		30.5	55.4	12.7	1.3		34.7	54.3	11	0		
Total %	2.1	0.4	0.6	0.1	3.3	0.6	16.5	14.3	0	31.4	2.4	4.4	1	0.1	8	19.9	31.1	6.3	0	57.3	
Vehicles	349	66	101	18	534	89	2785	2402								3343	5252	1067			16829
% Vehicles	95.9	98.5	94.4	94.7	95.9	93.7	98.2	98.3	100	98.2	98.6	99.2	97.7	77.8	98.5	98.1	98.5	98.6	0	98.4	98.2
Trucks	15	1	6	1	23	6	50	41	0	97	6	6	4	4	20	65	81	15	0	161	301
% Trucks	4.1	1.5	5.6	5.3	4.1	6.3	1.8	1.7	0	1.8	1.4	0.8	2.3	22.2	1.5	1.9	1.5	1.4	0	1.6	1.8

# Short Elliott Hendrickson Inc.

3535 Vadnais Center Drive  
St. Paul, MN 55110

"Building a Better World for All of Us"



## TRAFFIC DATA

TH 52 & 80th St E Ramp

Ref.Pt.: 122.490

Data By: Short Elliott Hendrickson, Inc.

TURN MOVEMENT COUNT

File Name : TH 52 & 80th St E Ramp 2019

Site Code : 2b

Start Date : 4/23/2019

Page No : 3

Start Time	TH 52 Northbound Ramp Southbound					80th St Westbound					Broderick Blvd Northbound					80th St Eastbound					Int. Total
	Left	Thru	Right	Peds	App. Total	Left	Thru	Right	Peds	App. Total	Left	Thru	Right	Peds	App. Total	Left	Thru	Right	Peds	App. Total	
Peak Hour Analysis From 06:00 to 08:45 - Peak 1 of 1																					
Peak Hour for Entire Intersection Begins at 07:00																					
07:00	13	0	2	0	15	0	44	77	0	121	2	25	0	0	27	92	87	6	0	185	348
07:15	7	1	1	0	9	1	54	101	0	156	8	30	4	2	44	114	124	18	0	256	465
07:30	18	2	0	1	21	0	67	91	0	158	4	28	8	0	40	129	114	18	0	261	480
07:45	19	5	6	0	30	0	71	61	0	132	9	19	1	0	29	118	100	42	0	260	451
Total Volume	57	8	9	1	75	1	236	330	0	567	23	102	13	2	140	453	425	84	0	962	1744
% App. Total	76	10.7	12	1.3		0.2	41.6	58.2	0		16.4	72.9	9.3	1.4		47.1	44.2	8.7	0		
PHF	.750	.400	.375	.250	.625	.250	.831	.817	.000	.897	.639	.850	.406	.250	.795	.878	.857	.500	.000	.921	.908

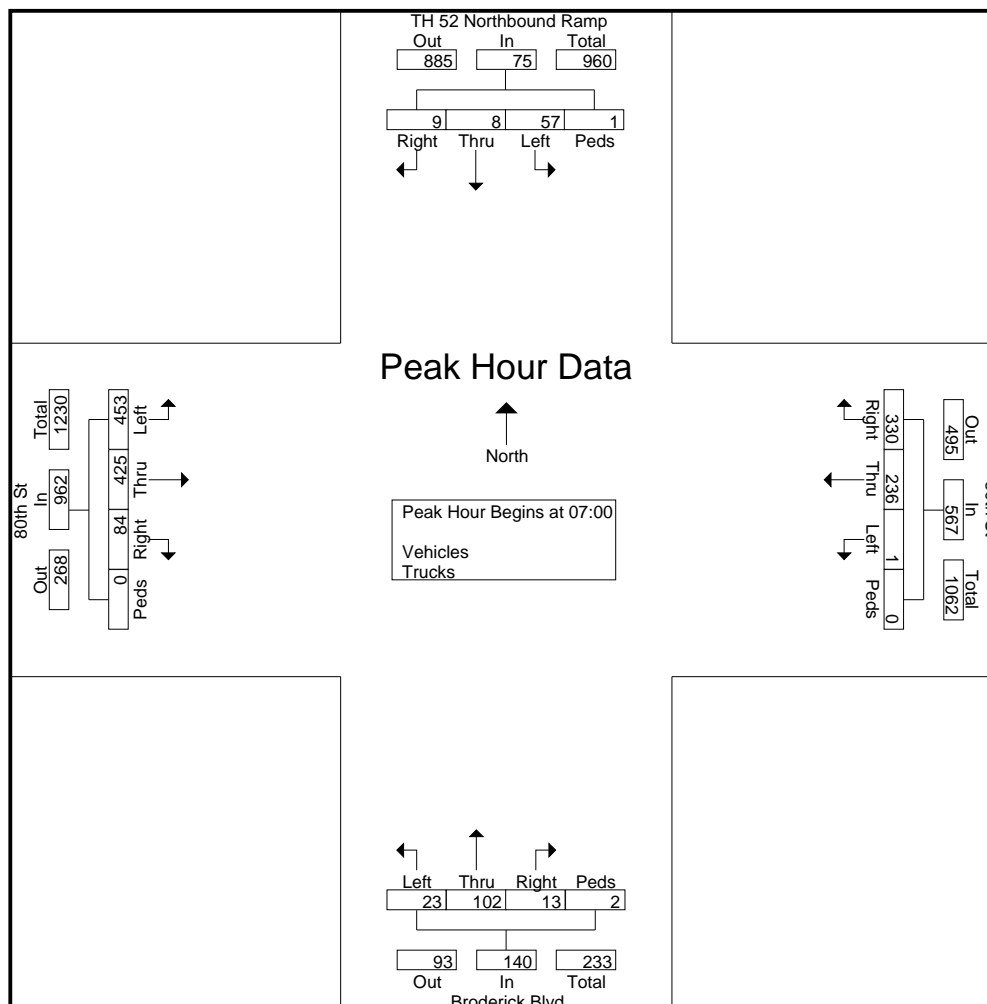

# Short Elliott Hendrickson Inc.

3535 Vadnais Center Drive  
St. Paul, MN 55110

"Building a Better World for All of Us"



## TRAFFIC DATA

TH 52 & 80th St E Ramp

Ref.Pt.: 122.490

Data By: Short Elliott Hendrickson, Inc.

TURN MOVEMENT COUNT

File Name : TH 52 & 80th St E Ramp 2019

Site Code : 2b

Start Date : 4/23/2019

Page No : 4

Start Time	TH 52 Northbound Ramp Southbound					80th St Westbound					Broderick Blvd Northbound					80th St Eastbound					Int. Total
	Left	Thru	Right	Peds	App. Total	Left	Thru	Right	Peds	App. Total	Left	Thru	Right	Peds	App. Total	Left	Thru	Right	Peds	App. Total	
Peak Hour Analysis From 11:00 to 12:45 - Peak 1 of 1 Peak Hour for Entire Intersection Begins at 11:30																					
11:30	6	1	1	0	8	1	39	44	0	84	15	12	6	0	33	42	95	25	0	162	287
11:45	10	2	1	0	13	0	46	44	0	90	14	16	7	2	39	34	95	32	0	161	303
12:00	4	1	2	0	7	3	37	40	0	80	13	15	2	1	31	51	103	22	0	176	294
12:15	7	1	1	0	9	2	69	55	0	126	11	18	6	0	35	32	98	26	0	156	326
Total Volume	27	5	5	0	37	6	191	183	0	380	53	61	21	3	138	159	391	105	0	655	1210
% App. Total	73	13.5	13.5	0		1.6	50.3	48.2	0		38.4	44.2	15.2	2.2		24.3	59.7	16	0		
PHF	.675	.625	.625	.000	.712	.500	.692	.832	.000	.754	.883	.847	.750	.375	.885	.779	.949	.820	.000	.930	.928

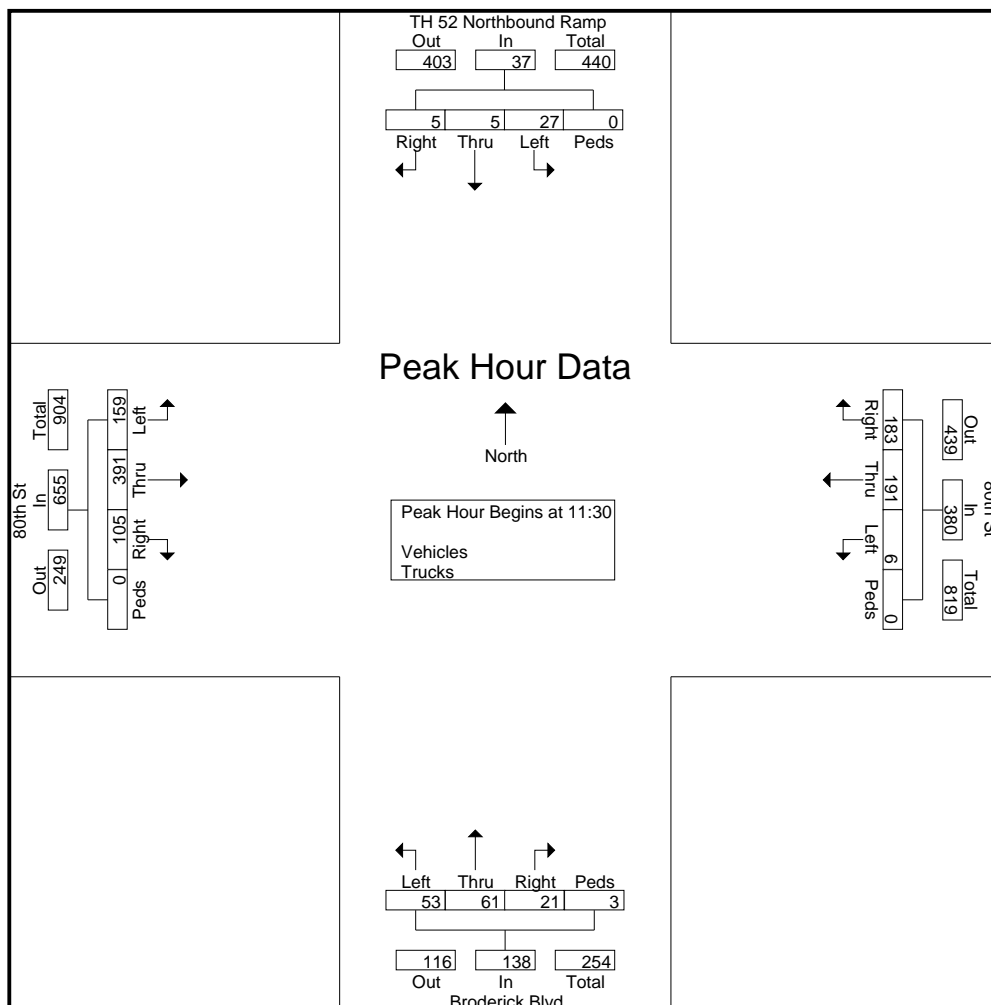

# Short Elliott Hendrickson Inc.

3535 Vadnais Center Drive  
St. Paul, MN 55110

"Building a Better World for All of Us"



## TRAFFIC DATA

TH 52 & 80th St E Ramp

Ref.Pt.: 122.490

Data By: Short Elliott Hendrickson, Inc.

TURN MOVEMENT COUNT

File Name : TH 52 & 80th St E Ramp 2019

Site Code : 2b

Start Date : 4/23/2019

Page No : 5

Start Time	TH 52 Northbound Ramp Southbound					80th St Westbound					Broderick Blvd Northbound					80th St Eastbound					Int. Total
	Left	Thru	Right	Peds	App. Total	Left	Thru	Right	Peds	App. Total	Left	Thru	Right	Peds	App. Total	Left	Thru	Right	Peds	App. Total	
Peak Hour Analysis From 15:00 to 17:45 - Peak 1 of 1 Peak Hour for Entire Intersection Begins at 16:30																					
16:30	15	1	3	2	21	2	57	48	2	109	12	20	5	0	37	105	174	25	0	304	471
16:45	9	1	6	0	16	1	80	36	0	117	13	15	4	0	32	96	202	29	0	327	492
17:00	7	1	2	0	10	1	72	38	0	111	5	10	1	0	16	109	177	26	0	312	449
17:15	7	1	6	0	14	2	65	31	0	98	8	11	5	0	24	96	189	33	0	318	454
Total Volume	38	4	17	2	61	6	274	153	2	435	38	56	15	0	109	406	742	113	0	1261	1866
% App. Total	62.3	6.6	27.9	3.3		1.4	63	35.2	0.5		34.9	51.4	13.8	0		32.2	58.8	9	0		
PHF	.633	1.00	.708	.250	.726	.750	.856	.797	.250	.929	.731	.700	.750	.000	.736	.931	.918	.856	.000	.964	.948

