

Albeck Gerken, Inc

Transportation Engineers

Traffic Data Collection

TH-52 at 80th St E, west ramps
 Inver Grove Heights, MN
 Ref.Pt.: 122.516
 TURN MOVEMENT COUNT

File Name : TH-52 at 80th St E west ramp 2012
 Site Code : 39
 Start Date : 1/13/2012
 Page No : 1

Groups Printed- Cars - Heavy Vehicles

Start Time	ramp from / loop to TH-52 SB Southbound				80th St E Westbound				Barnes Ave E Northbound				80th St E Eastbound				Int. Total
	Left	Thru	Right	Peds	Left	Thru	Right	Peds	Left	Thru	Right	Peds	Left	Thru	Right	Peds	
06:00	10	24	4	0	19	7	1	0	0	0	28	0	1	14	3	0	111
06:15	10	28	3	1	17	4	7	0	0	0	31	0	0	16	3	0	120
06:30	18	32	7	2	29	14	6	0	5	0	41	0	2	24	3	0	183
06:45	49	35	12	0	26	20	4	0	2	0	58	0	1	27	2	0	236
Total	87	119	26	3	91	45	18	0	7	0	158	0	4	81	11	0	650
07:00	62	30	6	0	40	13	4	0	5	0	70	0	0	36	0	0	266
07:15	67	35	8	0	43	28	2	0	2	0	70	0	1	38	3	0	297
07:30	85	46	14	0	40	16	4	0	6	1	91	0	1	34	3	0	341
07:45	136	53	19	0	27	21	7	0	9	0	112	0	1	42	5	0	432
Total	350	164	47	0	150	78	17	0	22	1	343	0	3	150	11	0	1336
08:00	60	41	8	0	30	31	2	0	4	0	48	1	1	29	2	0	257
08:15	64	27	8	1	24	16	3	0	7	0	37	0	0	24	8	0	219
08:30	84	31	7	0	19	22	4	0	3	0	57	0	0	31	3	0	261
08:45	98	18	18	1	24	26	4	0	5	0	86	0	0	47	2	0	329
Total	306	117	41	2	97	95	13	0	19	0	228	1	1	131	15	0	1066
09:00	51	12	11	1	15	18	4	0	4	0	45	0	2	22	0	0	185
09:15	41	14	10	0	10	10	6	0	4	0	44	0	0	18	3	0	160
09:30	68	12	11	0	14	16	3	0	3	0	43	0	1	26	1	0	198
09:45	88	18	10	1	26	23	9	0	4	0	52	0	0	44	2	0	277
Total	248	56	42	2	65	67	22	0	15	0	184	0	3	110	6	0	820
10:00	53	13	4	0	24	15	5	0	1	2	29	0	0	49	9	0	204
10:15	61	25	5	0	10	19	2	0	1	0	38	0	0	34	6	0	201
10:30	43	15	3	0	15	17	3	0	1	0	31	0	0	27	6	0	161
10:45	74	13	5	0	20	14	7	0	6	0	35	0	2	34	3	0	213
Total	231	66	17	0	69	65	17	0	9	2	133	0	2	144	24	0	779
11:00	55	7	9	0	23	18	9	0	3	0	16	0	1	16	4	0	161
11:15	53	15	9	0	20	13	11	0	3	0	34	0	2	23	5	0	188
11:30	60	10	3	0	24	22	8	0	4	1	37	0	1	61	6	0	237
11:45	76	26	8	0	32	25	10	0	0	0	45	0	4	35	7	0	268
Total	244	58	29	0	99	78	38	0	10	1	132	0	8	135	22	0	854
12:00	45	17	5	0	34	16	6	0	3	0	30	0	3	40	6	0	205
12:15	39	15	6	0	21	26	4	0	1	0	29	1	1	30	6	0	179
12:30	41	13	15	0	24	19	7	0	3	1	30	0	2	28	6	0	189
12:45	60	10	8	0	35	25	10	0	2	0	40	0	1	24	5	0	220
Total	185	55	34	0	114	86	27	0	9	1	129	1	7	122	23	0	793
13:00	63	16	9	0	29	21	11	0	4	0	32	0	2	20	2	0	209
13:15	57	8	8	1	28	24	12	0	4	0	30	0	1	29	4	0	206
13:30	58	12	9	0	23	26	13	0	1	0	43	0	0	26	4	0	215
13:45	89	17	7	0	33	24	10	0	4	0	43	0	2	29	1	0	259
Total	267	53	33	1	113	95	46	0	13	0	148	0	5	104	11	0	889
14:00	50	25	11	0	26	26	6	0	2	0	28	0	0	28	4	0	206
14:15	57	27	7	3	28	27	9	0	5	0	34	0	2	32	4	0	235
14:30	68	20	6	0	33	38	7	0	4	1	44	1	0	28	1	0	251
14:45	68	23	10	0	31	28	6	0	1	0	65	0	2	32	3	0	269
Total	243	95	34	3	118	119	28	0	12	1	171	1	4	120	12	0	961
15:00	59	21	7	2	30	23	8	0	5	0	50	1	2	46	5	1	260
15:15	73	20	16	0	42	25	9	0	2	0	52	0	2	33	3	1	278
15:30	82	28	8	0	32	26	4	0	1	0	54	2	0	35	7	1	280
15:45	95	37	14	1	17	16	4	0	3	0	63	0	0	34	7	0	291
Total	309	106	45	3	121	90	25	0	11	0	219	3	4	148	22	3	1109

Albeck Gerken, Inc

Transportation Engineers

Traffic Data Collection

TH-52 at 80th St E, west ramps
Inver Grove Heights, MN
Ref.Pt.: 122.516
TURN MOVEMENT COUNT

File Name : TH-52 at 80th St E west ramp 2012
Site Code : 39
Start Date : 1/13/2012
Page No : 2

Groups Printed- Cars - Heavy Vehicles

Start Time	ramp from / loop to TH-52 SB Southbound				80th St E Westbound				Barnes Ave E Northbound				80th St E Eastbound				Int. Total
	Left	Thru	Right	Peds	Left	Thru	Right	Peds	Left	Thru	Right	Peds	Left	Thru	Right	Peds	
16:00	104	32	6	1	24	16	0	0	2	0	63	0	4	54	8	1	315
16:15	124	39	14	2	31	30	3	0	2	1	78	5	2	42	3	1	377
16:30	97	46	13	4	30	43	4	0	6	2	80	0	3	43	3	0	374
16:45	125	56	19	1	23	27	2	0	11	0	94	0	1	39	3	2	403
Total	450	173	52	8	108	116	9	0	21	3	315	5	10	178	17	4	1469
17:00	121	47	18	0	31	26	5	2	1	1	82	6	1	49	7	2	399
17:15	126	52	24	1	26	39	5	0	3	0	93	0	2	36	8	0	415
17:30	129	52	19	1	35	37	3	0	4	0	68	0	2	53	3	1	407
17:45	147	48	31	1	38	43	2	0	16	0	84	0	1	56	7	0	474
Total	523	199	92	3	130	145	15	2	24	1	327	6	6	194	25	3	1695
18:00	76	33	20	0	30	35	2	0	12	0	62	2	2	37	8	1	320
18:15	71	39	23	2	19	32	1	0	5	0	40	2	0	39	6	1	280
18:30	51	26	16	0	23	24	3	1	2	0	41	2	2	37	5	0	233
18:45	40	29	9	1	11	41	1	1	2	1	39	1	2	37	2	1	218
Total	238	127	68	3	83	132	7	2	21	1	182	7	6	150	21	3	1051
Grand Total	3681	1388	560	28	1358	1211	282	4	193	11	2669	24	63	1767	220	13	13472
Apprch %	65.1	24.5	9.9	0.5	47.6	42.4	9.9	0.1	6.7	0.4	92.1	0.8	3.1	85.7	10.7	0.6	
Total %	27.3	10.3	4.2	0.2	10.1	9	2.1	0	1.4	0.1	19.8	0.2	0.5	13.1	1.6	0.1	
Cars	3625	1273	528	28	1335	1162	274	4	190	9	2549	23	60	1646	211	13	12930
% Cars	98.5	91.7	94.3	100	98.3	96	97.2	100	98.4	81.8	95.5	95.8	95.2	93.2	95.9	100	96
Heavy Vehicles	56	115	32	0	23	49	8	0	3	2	120	1	3	121	9	0	542
% Heavy Vehicles	1.5	8.3	5.7	0	1.7	4	2.8	0	1.6	18.2	4.5	4.2	4.8	6.8	4.1	0	4

Albeck Gerken, Inc

Transportation Engineers

Traffic Data Collection

TH-52 at 80th St E, west ramps
 Inver Grove Heights, MN
 Ref.Pt.: 122.516
 TURN MOVEMENT COUNT

File Name : TH-52 at 80th St E west ramp 2012
 Site Code : 39
 Start Date : 1/13/2012
 Page No : 3

Start Time	ramp from / loop to TH-52 SB Southbound					80th St E Westbound					Barnes Ave E Northbound					80th St E Eastbound					Int. Total
	Left	Thru	Right	Peds	App. Total	Left	Thru	Right	Peds	App. Total	Left	Thru	Right	Peds	App. Total	Left	Thru	Right	Peds	App. Total	
Peak Hour Analysis From 06:00 to 11:45 - Peak 1 of 1																					
Peak Hour for Entire Intersection Begins at 07:00																					
07:00	62	30	6	0	98	40	13	4	0	57	5	0	70	0	75	0	36	0	0	36	266
07:15	67	35	8	0	110	43	28	2	0	73	2	0	70	0	72	1	38	3	0	42	297
07:30	85	46	14	0	145	40	16	4	0	60	6	1	91	0	98	1	34	3	0	38	341
07:45	136	53	19	0	208	27	21	7	0	55	9	0	112	0	121	1	42	5	0	48	432
Total Volume	350	164	47	0	561	150	78	17	0	245	22	1	343	0	366	3	150	11	0	164	1336
% App. Total	62.4	29.2	8.4	0		61.2	31.8	6.9	0		6	0.3	93.7	0		1.8	91.5	6.7	0		
PHF	.643	.774	.618	.000	.674	.872	.696	.607	.000	.839	.611	.250	.766	.000	.756	.750	.893	.550	.000	.854	.773

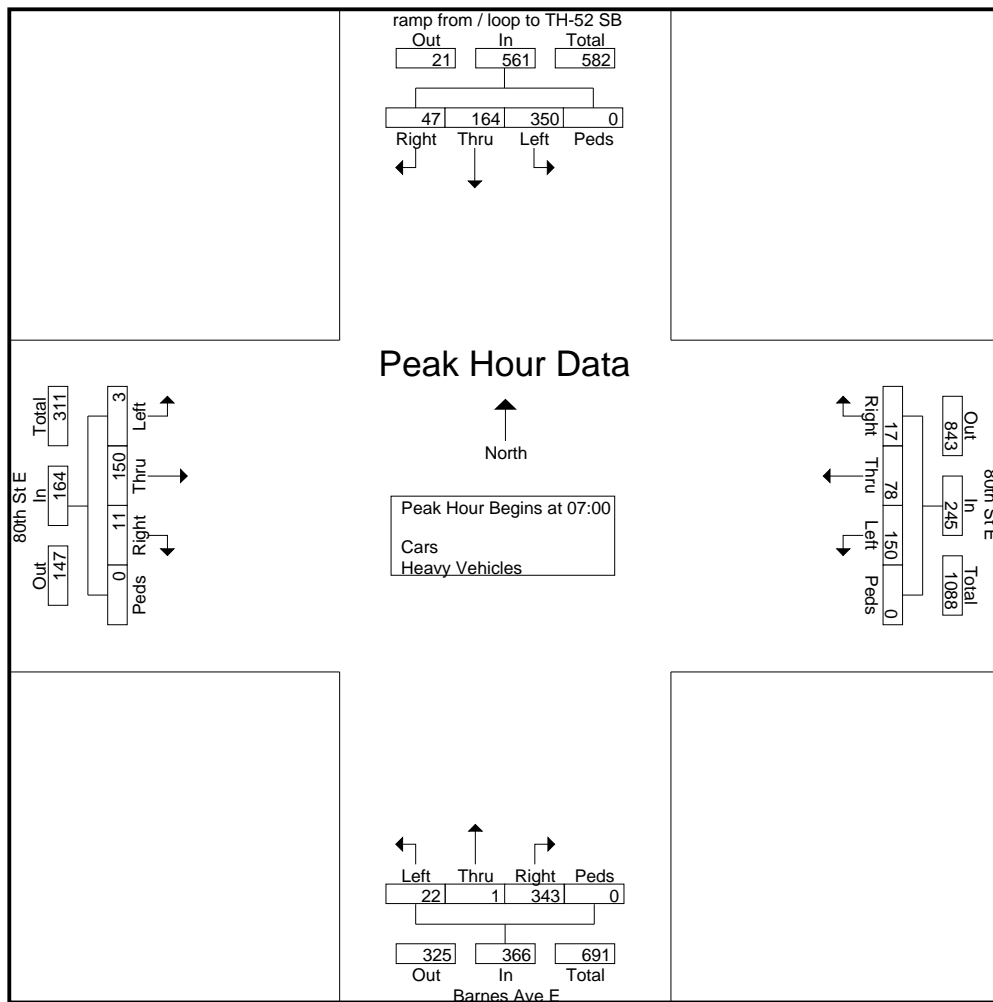

Albeck Gerken, Inc

Transportation Engineers

Traffic Data Collection

TH-52 at 80th St E, west ramps

Inver Grove Heights, MN

Ref.Pt.: 122.516

TURN MOVEMENT COUNT

File Name : TH-52 at 80th St E west ramp 2012

Site Code : 39

Start Date : 1/13/2012

Page No : 4

Start Time	ramp from / loop to TH-52 SB Southbound					80th St E Westbound					Barnes Ave E Northbound					80th St E Eastbound					Int. Total
	Left	Thru	Right	Peds	App. Total	Left	Thru	Right	Peds	App. Total	Left	Thru	Right	Peds	App. Total	Left	Thru	Right	Peds	App. Total	
Peak Hour Analysis From 12:00 to 18:45 - Peak 1 of 1																					
Peak Hour for Entire Intersection Begins at 17:00																					
17:00	121	47	18	0	186	31	26	5	2	64	1	1	82	6	90	1	49	7	2	59	399
17:15	126	52	24	1	203	26	39	5	0	70	3	0	93	0	96	2	36	8	0	46	415
17:30	129	52	19	1	201	35	37	3	0	75	4	0	68	0	72	2	53	3	1	59	407
17:45	147	48	31	1	227	38	43	2	0	83	16	0	84	0	100	1	56	7	0	64	474
Total Volume	523	199	92	3	817	130	145	15	2	292	24	1	327	6	358	6	194	25	3	228	1695
% App. Total	64	24.4	11.3	0.4		44.5	49.7	5.1	0.7		6.7	0.3	91.3	1.7		2.6	85.1	11	1.3		
PHF	.889	.957	.742	.750	.900	.855	.843	.750	.250	.880	.375	.250	.879	.250	.895	.750	.866	.781	.375	.891	.894

