



Minnesota Dept. of Transportation

Traffic Data Collection -Metro

TH-61 AT TH-97 / 210TH ST SOUTH JCT
 Ref.Pt;
 Jamar # T-2638 CAH
 TURN MOVEMENT COUNT

File Name : Not Named 4
 Site Code : 00000000
 Start Date : 9/12/2012
 Page No : 1

Groups Printed- Unshifted

Start Time	TH-61 Southbound				TH 97 S JCT Westbound				TH-61 Northbound				TH-97 / 210TH ST SOUTH JCT Eastbound				Int. Total
	Right	Thru	Left	Peds	Right	Thru	Left	Peds	Right	Thru	Left	Peds	Right	Thru	Left	Peds	
06:00	228	33	3	0	3	38	0	0	2	7	13	0	20	1	31	0	379
06:15	166	41	8	0	9	32	0	0	0	9	9	0	23	5	34	0	336
06:30	178	54	2	0	6	18	1	0	1	14	7	0	11	7	42	0	341
06:45	165	41	9	0	9	28	4	0	5	21	9	0	14	22	52	0	379
Total	737	169	22	0	27	116	5	0	8	51	38	0	68	35	159	0	1435
07:00	164	51	7	0	10	37	4	0	3	22	9	0	10	29	77	0	423
07:15	125	52	36	0	16	20	3	0	8	40	8	0	5	71	100	0	484
07:30	137	43	40	0	100	32	5	0	1	35	7	0	10	60	88	0	558
07:45	160	57	35	0	27	23	1	0	7	37	4	0	11	35	70	0	467
Total	586	203	118	0	153	112	13	0	19	134	28	0	36	195	335	0	1932
08:00	140	46	7	0	8	20	0	0	3	28	12	0	9	11	61	0	345
08:15	137	24	2	0	4	10	1	0	1	32	13	0	4	5	66	0	299
08:30	107	44	6	0	10	21	1	0	0	37	7	0	7	14	61	0	315
08:45	130	55	5	0	22	24	2	0	1	48	19	0	15	8	57	0	386
Total	514	169	20	0	44	75	4	0	5	145	51	0	35	38	245	0	1345
*** BREAK ***																	
11:00	69	48	13	0	4	13	0	0	2	47	8	0	6	7	72	0	289
11:15	71	43	11	0	9	5	0	0	5	51	6	0	6	4	41	0	252
11:30	97	57	8	0	8	6	3	0	1	58	14	0	8	5	65	0	330
11:45	89	48	13	0	13	12	2	0	1	52	3	0	6	12	79	0	330
Total	326	196	45	0	34	36	5	0	9	208	31	0	26	28	257	0	1201
12:00	109	45	9	0	9	4	0	0	2	48	3	0	5	5	50	0	289
12:15	69	45	11	0	6	2	1	0	0	47	7	0	8	15	64	0	275
12:30	74	46	13	0	9	8	3	0	1	59	5	0	9	6	57	0	290
12:45	70	43	11	0	4	11	1	0	2	67	14	0	8	7	71	0	309
Total	322	179	44	0	28	25	5	0	5	221	29	0	30	33	242	0	1163
*** BREAK ***																	
14:00	77	58	15	0	12	5	0	0	2	63	9	0	14	11	114	0	380
14:15	99	51	27	0	52	19	2	0	0	47	9	0	14	12	110	0	442
14:30	82	59	16	1	66	47	2	0	3	65	12	0	12	18	118	0	501
14:45	75	67	19	0	45	40	4	0	3	66	17	0	14	14	107	1	472
Total	333	235	77	1	175	111	8	0	8	241	47	0	54	55	449	1	1795
15:00	91	57	14	0	13	23	3	0	2	77	11	0	6	25	117	0	439
15:15	107	64	16	0	15	13	2	0	1	76	11	0	9	13	193	0	520
15:30	112	54	10	0	6	19	12	0	0	71	14	0	27	15	164	0	504
15:45	115	68	12	0	22	23	2	0	4	97	16	0	23	22	213	0	617
Total	425	243	52	0	56	78	19	0	7	321	52	0	65	75	687	0	2080
16:00	107	62	19	0	21	6	3	0	4	91	18	0	20	34	210	0	595
16:15	124	63	16	0	11	16	3	0	3	110	27	0	25	35	231	2	666
16:30	101	63	15	0	17	17	4	0	6	86	20	0	15	44	224	0	612
16:45	91	47	24	0	15	21	1	0	7	85	18	0	14	36	200	0	559
Total	423	235	74	0	64	60	11	0	20	372	83	0	74	149	865	2	2432



Minnesota Dept. of Transportation

Traffic Data Collection -Metro

TH-61 AT TH-97 / 210TH ST SOUTH JCT
 Ref.Pt;
 Jamar # T-2638 CAH
 TURN MOVEMENT COUNT

File Name : Not Named 4
 Site Code : 00000000
 Start Date : 9/12/2012
 Page No : 2

Groups Printed- Unshifted

Start Time	TH-61 Southbound				TH 97 S JCT Westbound				TH-61 Northbound				TH-97 / 210TH ST SOUTH JCT Eastbound				Int. Total
	Right	Thru	Left	Peds	Right	Thru	Left	Peds	Right	Thru	Left	Peds	Right	Thru	Left	Peds	
17:00	118	68	23	0	9	17	4	0	8	106	20	0	14	35	237	0	659
17:15	90	54	27	0	24	23	4	0	5	102	11	0	22	27	215	0	604
17:30	115	49	29	0	20	22	4	0	9	82	19	0	10	40	188	0	587
17:45	101	48	26	0	22	19	5	0	7	78	13	0	15	29	213	0	576
Total	424	219	105	0	75	81	17	0	29	368	63	0	61	131	853	0	2426
Grand Total	4090	1848	557	1	656	694	87	0	110	2061	422	0	449	739	4092	3	15809
Apprch %	63	28.4	8.6	0	45.7	48.3	6.1	0	4.2	79.5	16.3	0	8.5	14	77.5	0.1	
Total %	25.9	11.7	3.5	0	4.1	4.4	0.6	0	0.7	13	2.7	0	2.8	4.7	25.9	0	



Minnesota Dept. of Transportation

Traffic Data Collection -Metro

TH-61 AT TH-97 / 210TH ST SOUTH JCT
 Ref.Pt;
 Jamar # T-2638 CAH
 TURN MOVEMENT COUNT

File Name : Not Named 4
 Site Code : 00000000
 Start Date : 9/12/2012
 Page No : 3

Start Time	TH-61 Southbound					TH 97 S JCT Westbound					TH-61 Northbound					TH-97 / 210TH ST SOUTH JCT Eastbound					Int. Total
	Right	Thru	Left	Peds	App. Total	Right	Thru	Left	Peds	App. Total	Right	Thru	Left	Peds	App. Total	Right	Thru	Left	Peds	App. Total	
Peak Hour Analysis From 06:00 to 08:45 - Peak 1 of 1																					
Peak Hour for Entire Intersection Begins at 07:00																					
07:00	164	51	7	0	222	10	37	4	0	51	3	22	9	0	34	10	29	77	0	116	423
07:15	125	52	36	0	213	16	20	3	0	39	8	40	8	0	56	5	71	100	0	176	484
07:30	137	43	40	0	220	100	32	5	0	137	1	35	7	0	43	10	60	88	0	158	558
07:45	160	57	35	0	252	27	23	1	0	51	7	37	4	0	48	11	35	70	0	116	467
Total Volume	586	203	118	0	907	153	112	13	0	278	19	134	28	0	181	36	195	335	0	566	1932
% App. Total	64.6	22.4	13	0		55	40.3	4.7	0		10.5	74	15.5	0		6.4	34.5	59.2	0		
PHF	.893	.890	.738	.000	.900	.383	.757	.650	.000	.507	.594	.838	.778	.000	.808	.818	.687	.838	.000	.804	.866

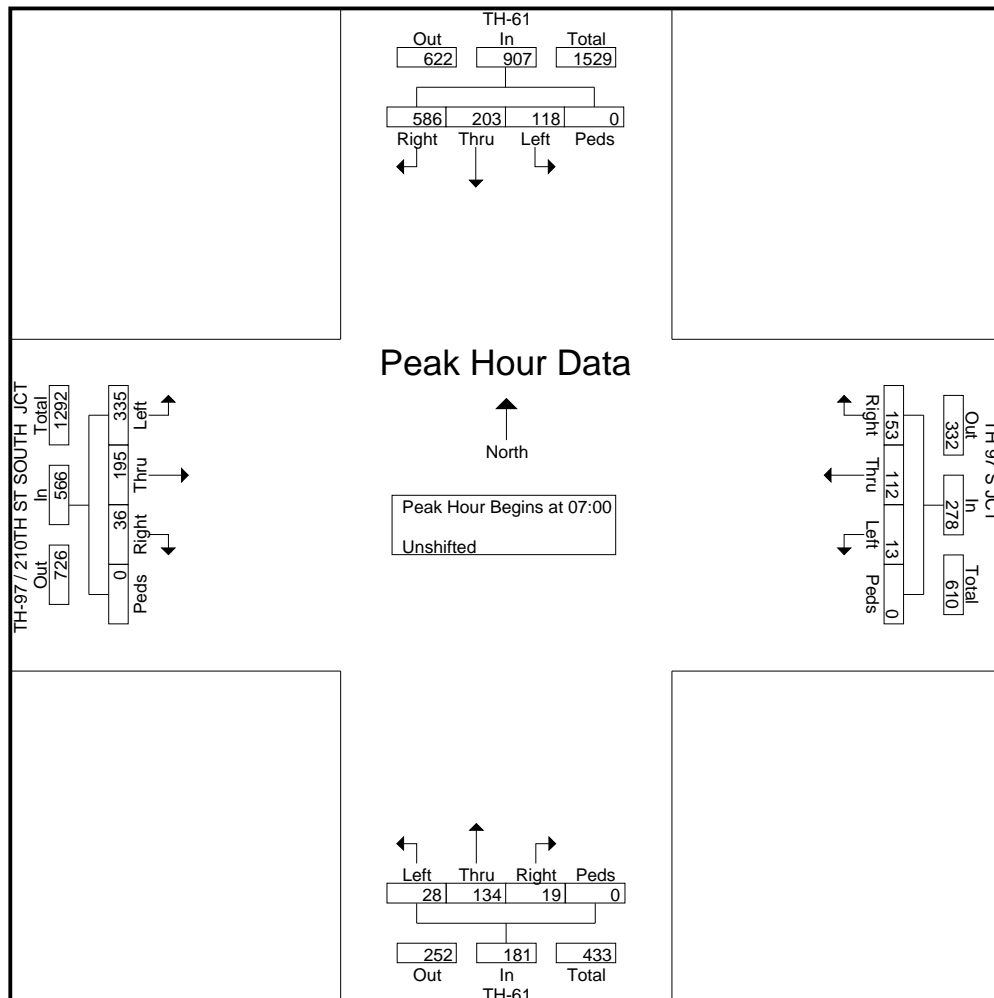



Minnesota Dept. of Transportation

Traffic Data Collection -Metro

TH-61 AT TH-97 / 210TH ST SOUTH JCT
 Ref.Pt;
 Jamar # T-2638 CAH
 TURN MOVEMENT COUNT

File Name : Not Named 4
 Site Code : 00000000
 Start Date : 9/12/2012
 Page No : 4

Start Time	TH-61 Southbound					TH 97 S JCT Westbound					TH-61 Northbound					TH-97 / 210TH ST SOUTH JCT Eastbound					Int. Total
	Rig ht	Thr u	Left	Ped s	App. Total	Rig ht	Thr u	Left	Ped s	App. Total	Right	Thr u	Left	Peds	App. Total	Right	Thr u	Left	Peds	App. Total	
Peak Hour Analysis From 11:00 to 12:45 - Peak 1 of 1																					
Peak Hour for Entire Intersection Begins at 11:30																					
11:30	97	57	8	0	162	8	6	3	0	17	1	58	14	0	73	8	5	65	0	78	330
11:45	89	48	13	0	150	13	12	2	0	27	1	52	3	0	56	6	12	79	0	97	330
12:00	109	45	9	0	163	9	4	0	0	13	2	48	3	0	53	5	5	50	0	60	289
12:15	69	45	11	0	125	6	2	1	0	9	0	47	7	0	54	8	15	64	0	87	275
Total Volume	364	195	41	0	600	36	24	6	0	66	4	205	27	0	236	27	37	258	0	322	1224
% App. Total	60.7	32.5	6.8	0		54.5	36.4	9.1	0		1.7	86.9	11.4	0		8.4	11.5	80.1	0		
PHF	.835	.855	.788	.000	.920	.692	.500	.500	.000	.611	.500	.884	.482	.000	.808	.844	.617	.816	.000	.830	.927

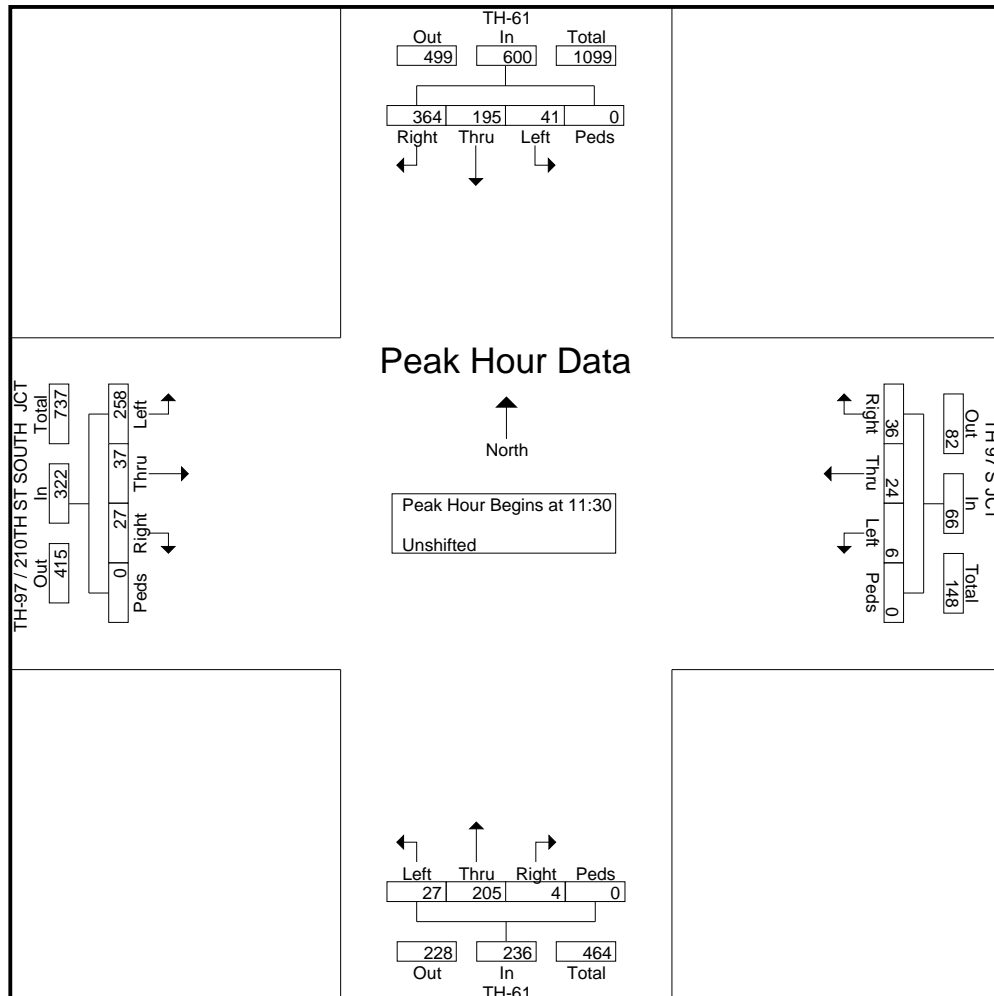



Minnesota Dept. of Transportation

Traffic Data Collection -Metro

TH-61 AT TH-97 / 210TH ST SOUTH JCT
 Ref.Pt;
 Jamar # T-2638 CAH
 TURN MOVEMENT COUNT

File Name : Not Named 4
 Site Code : 00000000
 Start Date : 9/12/2012
 Page No : 5

Start Time	TH-61 Southbound					TH 97 S JCT Westbound					TH-61 Northbound					TH-97 / 210TH ST SOUTH JCT Eastbound					Int. Total
	Rig ht	Thr u	Left	Ped s	App. Total	Rig ht	Thr u	Left	Ped s	App. Total	Right	Thr u	Left	Peds	App. Total	Right	Thr u	Left	Peds	App. Total	
16:15	124	63	16	0	203	11	16	3	0	30	3	110	27	0	140	25	35	231	2	293	666
16:30	101	63	15	0	179	17	17	4	0	38	6	86	20	0	112	15	44	224	0	283	612
16:45	91	47	24	0	162	15	21	1	0	37	7	85	18	0	110	14	36	200	0	250	559
17:00	118	68	23	0	209	9	17	4	0	30	8	106	20	0	134	14	35	237	0	286	659
Total Volume	434	241	78	0	753	52	71	12	0	135	24	387	85	0	496	68	150	892	2	1112	2496
% App. Total	57.6	32	10.4	0		38.5	52.6	8.9	0		4.8	78	17.1	0		6.1	13.5	80.2	0.2		
PHF	.875	.886	.813	.000	.901	.765	.845	.750	.000	.888	.750	.880	.787	.000	.886	.680	.852	.941	.250	.949	.937

Peak Hour Analysis From 14:00 to 17:45 - Peak 1 of 1
 Peak Hour for Entire Intersection Begins at 16:15

