

Alliant Engineering

Minneapolis, MN 55415

--TRAFFIC DATA --

I-35E at TH-110 , East Ramps
 Ref.Pt. 102.437
 data by Alliant Engineering
 TURN MOVEMENT COUNT

File Name : 414 - TH 110 and I-35E E Ramp
 Site Code : 414
 Start Date : 4/9/2015
 Page No : 1

Groups Printed- Cars - Trucks

Start Time	I-35E E Ramp Southbound				TH 110 Westbound				I-35E E Ramp Northbound				TH 110 Eastbound				Int. Total
	Left	Thru	Rght	Bikes	Left	Thru	Rght	Bikes	Left	Thru	Rght	Bikes	Left	Thru	Rght	Bikes	
06:00	2	0	13	0	0	143	28	0	0	0	0	0	8	52	0	0	246
06:15	7	0	13	0	0	215	50	0	0	0	0	0	7	76	0	0	368
06:30	13	0	17	0	0	294	77	0	0	0	0	0	21	106	0	0	528
06:45	18	0	23	0	0	357	91	0	0	0	0	0	29	151	0	0	669
Total	40	0	66	0	0	1009	246	0	0	0	0	0	65	385	0	0	1811
07:00	29	0	39	0	0	341	86	0	0	0	0	0	17	177	0	0	689
07:15	34	0	23	0	0	419	145	0	0	0	0	0	31	230	0	0	882
07:30	40	0	28	0	0	366	121	0	0	0	0	0	29	246	0	0	830
07:45	29	0	41	0	0	421	120	0	0	0	0	0	22	294	0	0	927
Total	132	0	131	0	0	1547	472	0	0	0	0	0	99	947	0	0	3328
08:00	53	0	52	0	0	276	112	0	0	0	0	0	30	245	0	0	768
08:15	49	0	31	0	0	307	99	0	0	0	0	0	24	215	0	0	725
08:30	41	0	76	0	0	303	96	0	0	0	0	0	30	196	0	0	742
08:45	29	0	45	0	0	271	87	0	0	0	0	0	33	199	0	0	664
Total	172	0	204	0	0	1157	394	0	0	0	0	0	117	855	0	0	2899
09:00	28	0	17	0	0	194	98	0	0	0	0	0	44	179	0	0	560
09:15	26	0	19	0	0	187	76	0	0	0	0	0	38	163	0	0	509
*** BREAK ***																	
Total	54	0	36	0	0	381	174	0	0	0	0	0	82	342	0	0	1069
*** BREAK ***																	
10:30	17	0	16	0	0	151	38	0	0	0	0	0	29	172	0	0	423
10:45	23	0	19	0	0	149	63	0	0	0	0	0	21	164	0	0	439
Total	40	0	35	0	0	300	101	0	0	0	0	0	50	336	0	0	862
11:00	30	0	8	0	0	149	66	0	0	0	0	0	30	160	0	0	443
11:15	28	0	23	0	0	155	58	0	0	0	0	0	34	187	0	0	485
11:30	31	0	20	0	0	156	84	0	0	0	0	0	32	186	0	0	509
11:45	36	0	22	0	0	205	59	0	0	0	0	0	36	199	0	0	557
Total	125	0	73	0	0	665	267	0	0	0	0	0	132	732	0	0	1994
12:00	30	0	26	0	0	162	55	0	0	0	0	0	35	197	0	0	505
12:15	22	0	32	0	0	197	59	0	0	0	0	0	27	196	0	0	533
12:30	29	0	20	0	0	194	70	0	0	0	0	0	31	210	0	0	554
12:45	37	0	30	0	0	157	61	0	0	0	0	0	30	201	0	0	516
Total	118	0	108	0	0	710	245	0	0	0	0	0	123	804	0	0	2108
13:00	24	0	19	0	0	135	71	0	0	0	0	0	36	199	0	0	484
13:15	32	0	19	0	0	158	59	0	0	0	0	0	22	191	0	0	481
*** BREAK ***																	
Total	56	0	38	0	0	293	130	0	0	0	0	0	58	390	0	0	965
*** BREAK ***																	
14:30	30	0	21	0	0	160	92	0	0	0	0	0	57	230	0	0	590
14:45	43	0	16	1	0	163	87	0	0	0	0	0	63	298	0	0	671
Total	73	0	37	1	0	323	179	0	0	0	0	0	120	528	0	0	1261
15:00	45	0	7	0	0	192	96	0	0	0	0	0	53	290	0	0	683
15:15	44	0	14	0	0	185	103	0	0	0	0	0	48	353	0	0	747
15:30	40	0	17	0	0	202	102	0	0	0	0	0	58	364	0	0	783
15:45	31	0	22	0	0	186	104	0	0	0	0	0	70	403	0	0	816
Total	160	0	60	0	0	765	405	0	0	0	0	0	229	1410	0	0	3029
16:00	32	0	30	0	0	204	84	0	0	0	0	0	60	369	0	0	779
16:15	32	0	13	0	0	209	95	0	0	0	0	0	55	440	0	0	844
16:30	41	0	23	0	0	236	104	0	0	0	0	0	75	390	0	0	869

Alliant Engineering

Minneapolis, MN 55415

--TRAFFIC DATA --

I-35E at TH-110 , East Ramps
 Ref.Pt. 102.437
 data by Alliant Engineering
 TURN MOVEMENT COUNT

File Name : 414 - TH 110 and I-35E E Ramp
 Site Code : 414
 Start Date : 4/9/2015
 Page No : 2

Groups Printed- Cars - Trucks

Start Time	I-35E E Ramp Southbound				TH 110 Westbound				I-35E E Ramp Northbound				TH 110 Eastbound				Int. Total
	Left	Thru	Rght	Bikes	Left	Thru	Rght	Bikes	Left	Thru	Rght	Bikes	Left	Thru	Rght	Bikes	
16:45	57	0	28	0	0	214	117	0	0	0	0	0	131	367	0	0	914
Total	162	0	94	0	0	863	400	0	0	0	0	0	321	1566	0	0	3406
17:00	61	0	30	0	0	217	97	0	0	0	0	0	65	418	0	0	888
17:15	65	0	21	0	0	228	117	0	0	0	0	0	90	423	0	0	944
17:30	69	0	46	0	0	237	108	0	0	0	0	0	58	335	0	0	853
17:45	59	0	39	0	0	234	95	0	0	0	0	0	73	381	0	0	881
Total	254	0	136	0	0	916	417	0	0	0	0	0	286	1557	0	0	3566
*** BREAK ***																	
Grand Total	1386	0	1018	1	0	8929	3430	0	0	0	0	0	1682	9852	0	0	26298
Apprch %	57.6	0	42.3	0	0	72.2	27.8	0	0	0	0	0	14.6	85.4	0	0	
Total %	5.3	0	3.9	0	0	34	13	0	0	0	0	0	6.4	37.5	0	0	
Cars	1357	0	994	1	0	8696	3332	0	0	0	0	0	1663	9573	0	0	25616
% Cars	97.9	0	97.6	100	0	97.4	97.1	0	0	0	0	0	98.9	97.2	0	0	97.4
Trucks	29	0	24	0	0	233	98	0	0	0	0	0	19	279	0	0	682
% Trucks	2.1	0	2.4	0	0	2.6	2.9	0	0	0	0	0	1.1	2.8	0	0	2.6

Alliant Engineering

Minneapolis, MN 55415

--TRAFFIC DATA --

I-35E at TH-110 , East Ramps
 Ref.Pt. 102.437
 data by Alliant Engineering
 TURN MOVEMENT COUNT

File Name : 414 - TH 110 and I-35E E Ramp
 Site Code : 414
 Start Date : 4/9/2015
 Page No : 3

Start Time	I-35E E Ramp Southbound					TH 110 Westbound					I-35E E Ramp Northbound					TH 110 Eastbound					Int. Total
	Left	Thru	Right	Bikes	App. Total	Left	Thru	Right	Bikes	App. Total	Left	Thru	Right	Bikes	App. Total	Left	Thru	Right	Bikes	App. Total	
Peak Hour Analysis From 06:00 to 08:45 - Peak 1 of 1																					
Peak Hour for Entire Intersection Begins at 07:15																					
07:15	34	0	23	0	57	0	419	145	0	564	0	0	0	0	0	31	230	0	0	261	882
07:30	40	0	28	0	68	0	366	121	0	487	0	0	0	0	0	29	246	0	0	275	830
07:45	29	0	41	0	70	0	421	120	0	541	0	0	0	0	0	22	294	0	0	316	927
08:00	53	0	52	0	105	0	276	112	0	388	0	0	0	0	0	30	245	0	0	275	768
Total Volume	156	0	144	0	300	0	1482	498	0	1980	0	0	0	0	0	112	1015	0	0	1127	3407
% App. Total	52	0	48	0		0	74.8	25.2	0		0	0	0	0		9.9	90.1	0	0		
PHF	.736	.000	.692	.000	.714	.000	.880	.859	.000	.878	.000	.000	.000	.000	.000	.903	.863	.000	.000	.892	.919

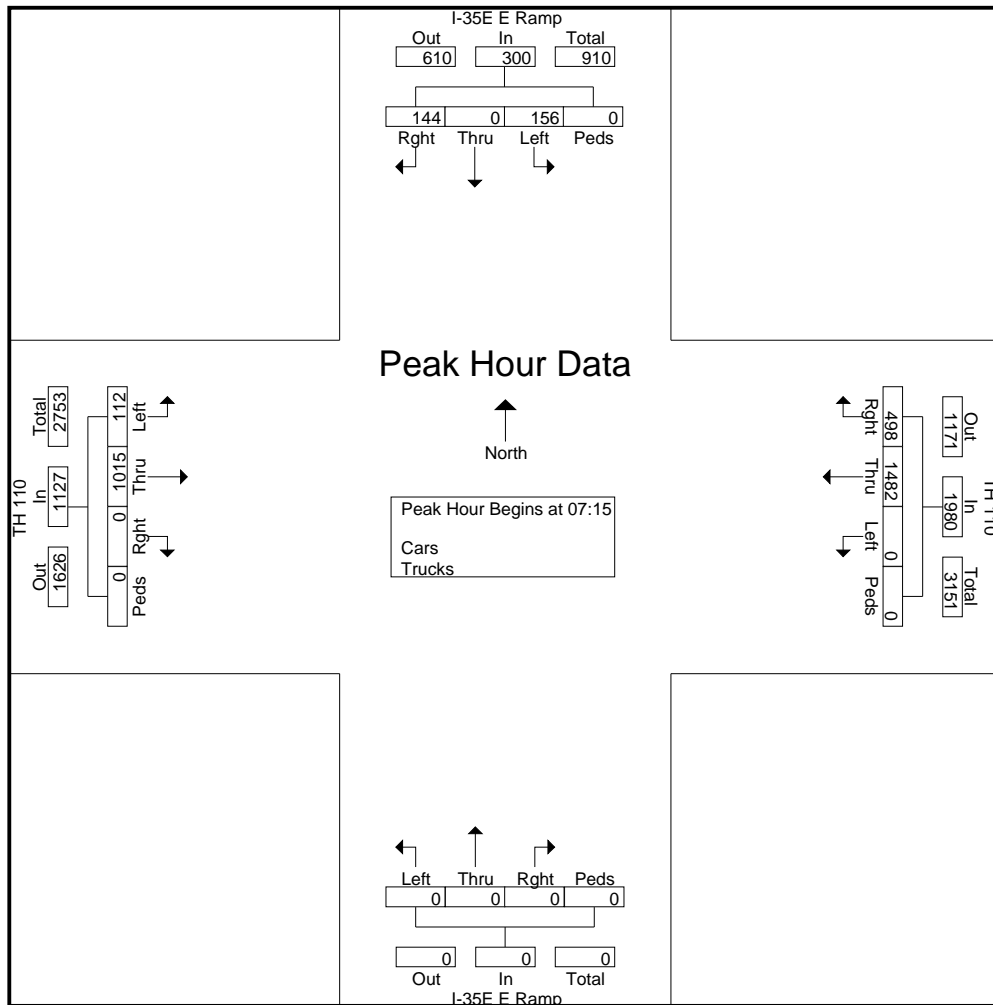

Alliant Engineering

Minneapolis, MN 55415

--TRAFFIC DATA --

I-35E at TH-110 , East Ramps
 Ref.Pt. 102.437
 data by Alliant Engineering
 TURN MOVEMENT COUNT

File Name : 414 - TH 110 and I-35E E Ramp
 Site Code : 414
 Start Date : 4/9/2015
 Page No : 4

Start Time	I-35E E Ramp Southbound					TH 110 Westbound					I-35E E Ramp Northbound					TH 110 Eastbound					Int. Total
	Left	Thru	Rght	Bikes	App. Total	Left	Thru	Rght	Bikes	App. Total	Left	Thru	Rght	Bikes	App. Total	Left	Thru	Rght	Bikes	App. Total	
Peak Hour Analysis From 15:00 to 18:00 - Peak 1 of 1																					
Peak Hour for Entire Intersection Begins at 16:30																					
16:30	41	0	23	0	64	0	236	104	0	340	0	0	0	0	0	75	390	0	0	465	869
16:45	57	0	28	0	85	0	214	117	0	331	0	0	0	0	0	131	367	0	0	498	914
17:00	61	0	30	0	91	0	217	97	0	314	0	0	0	0	0	65	418	0	0	483	888
17:15	65	0	21	0	86	0	228	117	0	345	0	0	0	0	0	90	423	0	0	513	944
Total Volume	224	0	102	0	326	0	895	435	0	1330	0	0	0	0	0	361	1598	0	0	1959	3615
% App. Total	68.7	0	31.3	0		0	67.3	32.7	0		0	0	0	0		18.4	81.6	0	0		
PHF	.862	.000	.850	.000	.896	.000	.948	.929	.000	.964	.000	.000	.000	.000	.000	.689	.944	.000	.000	.955	.957

