



# MINNESOTA DEPT OF TRANSPORTATION

## TRAFFIC DATA COLLECTION - METRO

I-35E AT TH-13, EAST RAMPS  
 REF.PT.: 102.437 (I-35E)  
 JAMAR #T2638 KF  
 TURN MOVEMENT COUNT

File Name : I-35E AT TH-13 EAST RAMPS 2007  
 Site Code : 00000000  
 Start Date : 1/24/2007  
 Page No : 1

**Groups Printed- Cars & Trucks**

Start Time	TH-13 Westbound				RAMP FROM / LOOP TO I-35E NB Northbound				TH-13 Eastbound				Int. Total
	Left	Thru	Right	Peds	Left	Thru	Right	Peds	Left	Thru	Right	Peds	
06:00	14	27	0	0	6	0	14	0	0	19	25	0	105
06:15	17	34	0	0	5	0	17	0	0	23	31	0	127
06:30	21	49	0	0	6	0	26	0	0	43	37	0	182
06:45	29	48	0	0	6	0	37	0	0	37	53	0	210
Total	81	158	0	0	23	0	94	0	0	122	146	0	624
07:00	55	50	0	0	5	0	36	0	0	46	75	0	267
07:15	68	70	0	0	4	0	24	0	0	50	89	0	305
07:30	71	69	0	0	4	0	17	0	0	76	91	0	328
07:45	65	70	0	0	6	0	19	0	0	74	94	0	328
Total	259	259	0	0	19	0	96	0	0	246	349	0	1228
08:00	56	41	0	0	8	0	24	0	0	54	81	0	264
08:15	40	82	0	0	10	0	28	0	0	50	75	0	285
08:30	49	46	0	0	18	0	25	0	0	47	64	0	249
08:45	48	49	0	0	14	0	24	0	0	44	76	0	255
Total	193	218	0	0	50	0	101	0	0	195	296	0	1053
*** BREAK ***													
15:00	32	59	0	0	12	0	24	0	0	96	47	0	270
15:15	34	79	0	0	6	0	35	0	0	87	60	0	301
15:30	39	65	0	0	4	0	24	0	0	86	74	0	292
15:45	28	42	0	0	14	0	29	0	0	100	54	0	267
Total	133	245	0	0	36	0	112	0	0	369	235	0	1130
16:00	39	60	0	0	4	0	33	0	0	91	56	0	283
16:15	24	78	0	0	18	0	34	0	0	86	60	0	300
16:30	28	62	0	0	4	0	35	0	0	93	78	0	300
16:45	41	69	0	0	11	0	42	0	0	106	76	0	345
Total	132	269	0	0	37	0	144	0	0	376	270	0	1228
17:00	36	75	0	0	8	0	35	0	0	88	70	0	312
17:15	33	84	0	0	14	0	40	0	0	106	61	0	338
17:30	27	67	0	0	12	0	37	0	0	98	38	0	279
17:45	51	71	0	0	9	0	22	0	0	76	41	0	270
Total	147	297	0	0	43	0	134	0	0	368	210	0	1199
Grand Total	945	1446	0	0	208	0	681	0	0	1676	1506	0	6462
Apprch %	39.5	60.5	0	0	23.4	0	76.6	0	0	52.7	47.3	0	
Total %	14.6	22.4	0	0	3.2	0	10.5	0	0	25.9	23.3	0	



# MINNESOTA DEPT OF TRANSPORTATION

## TRAFFIC DATA COLLECTION - METRO

I-35E AT TH-13, EAST RAMPS  
 REF.PT.: 102.437 (I-35E)  
 JAMAR #T2638 KF  
 TURN MOVEMENT COUNT

File Name : I-35E AT TH-13 EAST RAMPS 2007  
 Site Code : 00000000  
 Start Date : 1/24/2007  
 Page No : 2

Start Time	TH-13 Westbound					RAMP FROM / LOOP TO I-35E NB Northbound					TH-13 Eastbound					Int. Total
	Left	Thru	Right	Peds	App. Total	Left	Thru	Right	Peds	App. Total	Left	Thru	Right	Peds	App. Total	
Peak Hour Analysis From 06:00 to 08:45 - Peak 1 of 1																
Peak Hour for Entire Intersection Begins at 07:00																
07:00	55	50	0	0	105	5	0	36	0	41	0	46	75	0	121	267
07:15	68	70	0	0	138	4	0	24	0	28	0	50	89	0	139	305
07:30	71	69	0	0	140	4	0	17	0	21	0	76	91	0	167	328
07:45	65	70	0	0	135	6	0	19	0	25	0	74	94	0	168	328
Total Volume	259	259	0	0	518	19	0	96	0	115	0	246	349	0	595	1228
% App. Total	50	50	0	0		16.5	0	83.5	0		0	41.3	58.7	0		
PHF	.912	.925	.000	.000	.925	.792	.000	.667	.000	.701	.000	.809	.928	.000	.885	.936

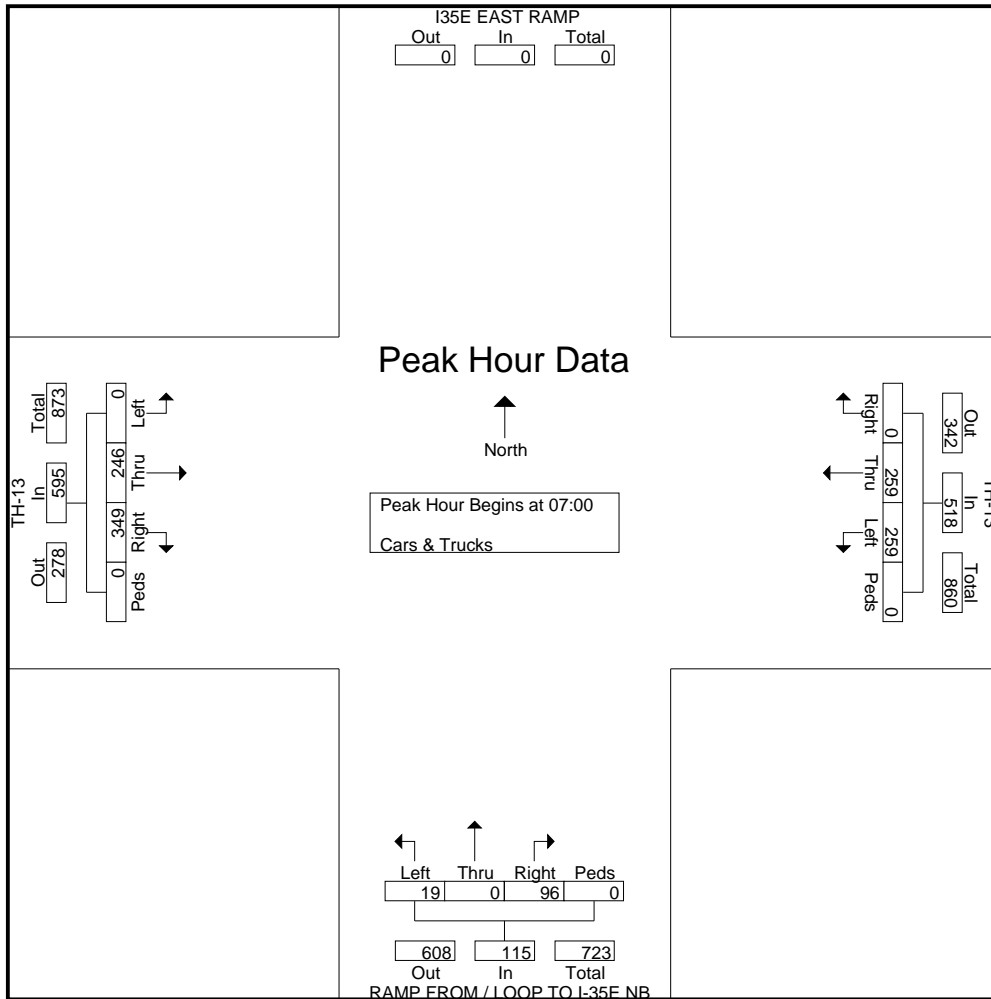



# MINNESOTA DEPT OF TRANSPORTATION

## TRAFFIC DATA COLLECTION - METRO

I-35E AT TH-13, EAST RAMPS  
 REF.PT.: 102.437 (I-35E)  
 JAMAR #T2638 KF  
 TURN MOVEMENT COUNT

File Name : I-35E AT TH-13 EAST RAMPS 2007  
 Site Code : 00000000  
 Start Date : 1/24/2007  
 Page No : 3

Start Time	TH-13 Westbound					RAMP FROM / LOOP TO I-35E NB Northbound					TH-13 Eastbound					Int. Total
	Left	Thru	Right	Peds	App. Total	Left	Thru	Right	Peds	App. Total	Left	Thru	Right	Peds	App. Total	
Peak Hour Analysis From 15:00 to 17:45 - Peak 1 of 1																
Peak Hour for Entire Intersection Begins at 16:30																
16:30	28	62	0	0	90	4	0	35	0	39	0	93	78	0	171	300
16:45	41	69	0	0	110	11	0	42	0	53	0	106	76	0	182	345
17:00	36	75	0	0	111	8	0	35	0	43	0	88	70	0	158	312
17:15	33	84	0	0	117	14	0	40	0	54	0	106	61	0	167	338
Total Volume	138	290	0	0	428	37	0	152	0	189	0	393	285	0	678	1295
% App. Total	32.2	67.8	0	0		19.6	0	80.4	0		0	58	42	0		
PHF	.841	.863	.000	.000	.915	.661	.000	.905	.000	.875	.000	.927	.913	.000	.931	.938

