



MINNESOTA DEPT OF TRANSPORTATION

TRAFFIC DATA COLLECTION - METRO

I-35E at TH-13, W ramps
 Ref.Pt.: 102.270
 JAMAR # D4-3365 CH
 TURN MOVEMENT COUNT

File Name : I-35E at TH-13 west ramps 2009
 Site Code : 00000000
 Start Date : 5/19/2009
 Page No : 1

Groups Printed- Cars & Trucks

Start Time	I-35E Southbound				TH-13 Westbound				I-35E Northbound				TH-13 Eastbound				Int. Total
	Left	Thru	Right	Peds	Left	Thru	Right	Peds	Left	Thru	Right	Peds	Left	Thru	Right	Peds	
06:00	9	0	25	0	12	15	0	1	0	0	0	0	0	37	8	2	109
06:15	10	0	38	0	10	27	0	0	0	0	0	0	0	46	15	1	147
06:30	13	0	47	0	24	23	0	0	0	0	0	0	0	69	10	0	186
06:45	16	0	43	0	30	35	0	1	0	0	0	0	0	65	15	4	209
Total	48	0	153	0	76	100	0	2	0	0	0	0	0	217	48	7	651
07:00	15	0	40	0	29	36	0	3	0	0	0	0	0	86	19	1	229
07:15	24	0	60	0	48	39	0	3	0	0	0	0	0	128	16	2	320
07:30	20	0	59	0	46	42	0	1	0	0	0	0	0	140	14	2	324
07:45	36	0	81	0	34	55	0	3	0	0	0	0	0	147	25	4	385
Total	95	0	240	0	157	172	0	10	0	0	0	0	0	501	74	9	1258
08:00	35	0	56	0	30	29	0	15	0	0	0	0	0	100	19	6	290
08:15	27	0	69	0	35	31	0	2	0	0	0	0	0	130	19	1	314
08:30	28	0	46	0	38	35	1	4	0	0	0	1	0	98	36	1	288
08:45	34	0	52	0	17	46	0	0	0	0	0	0	0	90	20	2	261
Total	124	0	223	0	120	141	1	21	0	0	0	1	0	418	94	10	1153
*** BREAK ***																	
15:00	60	1	95	0	30	45	0	3	0	0	0	0	0	90	23	4	351
15:15	76	0	66	0	35	43	1	2	0	0	0	0	0	102	18	3	346
15:30	69	1	89	1	26	41	0	2	0	0	0	0	0	122	11	3	365
15:45	81	1	109	0	33	57	0	4	0	0	0	0	0	96	21	1	403
Total	286	3	359	1	124	186	1	11	0	0	0	0	0	410	73	11	1465
16:00	69	0	125	0	34	39	0	5	0	0	0	0	0	115	18	1	406
16:15	62	1	126	0	46	57	0	2	0	0	0	0	1	103	17	3	418
16:30	67	0	129	0	39	70	0	3	0	0	0	0	0	94	18	2	422
16:45	88	2	129	0	50	87	0	6	0	0	0	0	0	132	19	2	515
Total	286	3	509	0	169	253	0	16	0	0	0	0	1	444	72	8	1761
17:00	92	4	137	1	43	63	1	7	0	0	0	0	0	116	21	10	495
17:15	77	0	138	2	21	77	0	7	0	0	0	0	0	124	19	6	471
17:30	105	2	141	0	38	67	2	7	0	0	0	0	0	121	22	7	512
17:45	86	0	114	0	32	49	0	3	0	0	0	0	0	120	31	4	439
Total	360	6	530	3	134	256	3	24	0	0	0	0	0	481	93	27	1917
Grand Total	1199	12	2014	4	780	1108	5	84	0	0	0	1	1	2471	454	72	8205
Apprch %	37.1	0.4	62.4	0.1	39.5	56	0.3	4.2	0	0	0	100	0	82.4	15.1	2.4	
Total %	14.6	0.1	24.5	0	9.5	13.5	0.1	1	0	0	0	0	0	30.1	5.5	0.9	



MINNESOTA DEPT OF TRANSPORTATION

TRAFFIC DATA COLLECTION - METRO

I-35E at TH-13, W ramps
 Ref.Pt.: 102.270
 JAMAR # D4-3365 CH
 TURN MOVEMENT COUNT

File Name : I-35E at TH-13 west ramps 2009
 Site Code : 00000000
 Start Date : 5/19/2009
 Page No : 2

Start Time	I-35E Southbound					TH-13 Westbound					I-35E Northbound					TH-13 Eastbound					Int. Total
	Left	Thru	Right	Peds	App. Total	Left	Thru	Right	Peds	App. Total	Left	Thru	Right	Peds	App. Total	Left	Thru	Right	Peds	App. Total	
Peak Hour Analysis From 06:00 to 08:45 - Peak 1 of 1																					
Peak Hour for Entire Intersection Begins at 07:15																					
07:15	24	0	60	0	84	48	39	0	3	90	0	0	0	0	0	0	128	16	2	146	320
07:30	20	0	59	0	79	46	42	0	1	89	0	0	0	0	0	0	140	14	2	156	324
07:45	36	0	81	0	117	34	55	0	3	92	0	0	0	0	0	0	147	25	4	176	385
08:00	35	0	56	0	91	30	29	0	15	74	0	0	0	0	0	0	100	19	6	125	290
Total Volume	115	0	256	0	371	158	165	0	22	345	0	0	0	0	0	0	515	74	14	603	1319
% App. Total	31	0	69	0		45.8	47.8	0	6.4		0	0	0	0	0	0	85.4	12.3	2.3		
PHF	.799	.000	.790	.000	.793	.823	.750	.000	.367	.938	.000	.000	.000	.000	.000	.000	.876	.740	.583	.857	.856

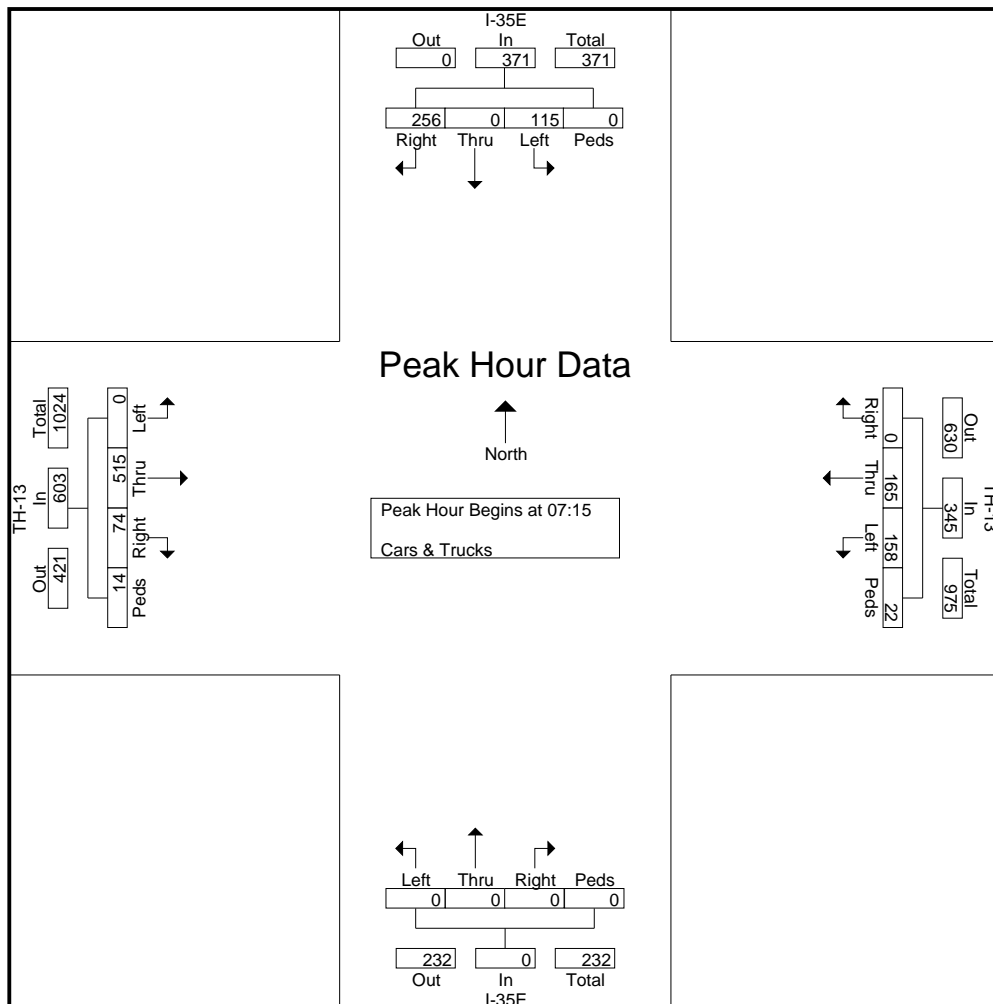



MINNESOTA DEPT OF TRANSPORTATION

TRAFFIC DATA COLLECTION - METRO

I-35E at TH-13, W ramps
 Ref.Pt.: 102.270
 JAMAR # D4-3365 CH
 TURN MOVEMENT COUNT

File Name : I-35E at TH-13 west ramps 2009
 Site Code : 00000000
 Start Date : 5/19/2009
 Page No : 3

Start Time	I-35E Southbound					TH-13 Westbound					I-35E Northbound					TH-13 Eastbound					Int. Total
	Left	Thru	Right	Peds	App. Total	Left	Thru	Right	Peds	App. Total	Left	Thru	Right	Peds	App. Total	Left	Thru	Right	Peds	App. Total	
Peak Hour Analysis From 15:00 to 17:45 - Peak 1 of 1																					
Peak Hour for Entire Intersection Begins at 16:45																					
16:45	88	2	129	0	219	50	87	0	6	143	0	0	0	0	0	0	132	19	2	153	515
17:00	92	4	137	1	234	43	63	1	7	114	0	0	0	0	0	0	116	21	10	147	495
17:15	77	0	138	2	217	21	77	0	7	105	0	0	0	0	0	0	124	19	6	149	471
17:30	105	2	141	0	248	38	67	2	7	114	0	0	0	0	0	0	121	22	7	150	512
Total Volume	362	8	545	3	918	152	294	3	27	476	0	0	0	0	0	0	493	81	25	599	1993
% App. Total	39.4	0.9	59.4	0.3		31.9	61.8	0.6	5.7		0	0	0	0		0	82.3	13.5	4.2		
PHF	.862	.500	.966	.375	.925	.760	.845	.375	.964	.832	.000	.000	.000	.000	.000	.000	.934	.920	.625	.979	.967

