

SEH Inc
Traffic Data Collection
TURN MOVEMENT COUNT

I-35E at Larpenteur Avenue, East Ramp
Ref.Pt.: 110.360
SEH Inc
TURN MOVEMENT COUNT

File Name : Larpenteur at NB I-35E Ramp
Site Code : 00000021
Start Date : 3/10/2011
Page No : 1

Groups Printed- Unshifted - Heavy Veh - All Bus

Start Time	ramp to I-35E NB Southbound				Larpenteur Ave Westbound				east frontage rd Northbound				Larpenteur Ave Eastbound				Int. Total
	Left	Thru	Right	Peds	Left	Thru	Right	Peds	Left	Thru	Right	Peds	Left	Thru	Right	Peds	
07:00	0	0	0	0	0	147	25	0	33	17	7	0	21	20	0	0	270
07:15	0	0	0	0	0	185	26	0	31	17	9	0	12	40	0	0	320
07:30	0	0	0	0	0	227	27	0	35	18	12	0	18	39	0	0	376
07:45	0	0	0	0	0	161	21	0	43	20	12	0	21	38	0	0	316
Total	0	0	0	0	0	720	99	0	142	72	40	0	72	137	0	0	1282
08:00	0	0	0	0	0	116	20	0	32	19	14	0	14	38	0	0	253
08:15	0	0	0	0	0	112	23	0	35	12	12	0	15	32	0	0	241
08:30	0	0	0	0	0	108	17	0	39	18	14	0	20	42	0	0	258
08:45	0	0	0	0	0	87	24	1	40	16	16	0	20	48	0	0	252
Total	0	0	0	0	0	423	84	1	146	65	56	0	69	160	0	0	1004
*** BREAK ***																	
16:00	0	0	0	0	0	83	21	0	42	29	28	0	28	106	0	0	337
16:15	0	0	0	0	0	75	23	0	41	27	24	0	51	130	0	0	371
16:30	0	0	0	0	0	56	23	0	37	34	26	0	53	134	0	0	363
16:45	0	0	0	0	0	57	16	0	42	24	23	0	42	143	0	0	347
Total	0	0	0	0	0	271	83	0	162	114	101	0	174	513	0	0	1418
17:00	0	0	0	0	0	59	18	0	38	26	17	0	53	131	0	0	342
17:15	0	0	0	1	0	58	21	0	34	26	26	1	33	149	0	0	349
17:30	0	0	0	0	0	69	16	0	42	32	26	0	52	119	0	0	356
17:45	0	0	0	0	0	59	28	0	37	26	31	0	41	113	0	0	335
Total	0	0	0	1	0	245	83	0	151	110	100	1	179	512	0	0	1382
Grand Total	0	0	0	1	0	1659	349	1	601	361	297	1	494	1322	0	0	5086
Apprch %	0	0	0	100	0	82.6	17.4	0	47.7	28.7	23.6	0.1	27.2	72.8	0	0	
Total %	0	0	0	0	0	32.6	6.9	0	11.8	7.1	5.8	0	9.7	26	0	0	
Unshifted	0	0	0	1	0	1627	347	1	584	359	291	1	488	1289	0	0	4988
% Unshifted	0	0	0	100	0	98.1	99.4	100	97.2	99.4	98	100	98.8	97.5	0	0	98.1
Heavy Veh	0	0	0	0	0	8	0	0	6	1	4	0	5	4	0	0	28
% Heavy Veh	0	0	0	0	0	0.5	0	0	1	0.3	1.3	0	1	0.3	0	0	0.6
All Bus	0	0	0	0	0	24	2	0	11	1	2	0	1	29	0	0	70
% All Bus	0	0	0	0	0	1.4	0.6	0	1.8	0.3	0.7	0	0.2	2.2	0	0	1.4

SEH Inc
Traffic Data Collection
TURN MOVEMENT COUNT

I-35E at Larpenteur Avenue, East Ramp
Ref.Pt.: 110.360
SEH Inc
TURN MOVEMENT COUNT

File Name : Larpenteur at NB I-35E Ramp
Site Code : 00000021
Start Date : 3/10/2011
Page No : 2

Start Time	ramp to I-35E NB Southbound					Larpenteur Ave Westbound					east frontage rd Northbound					Larpenteur Ave Eastbound					Int. Total
	Left	Thru	Right	Peds	App. Total	Left	Thru	Right	Peds	App. Total	Left	Thru	Right	Peds	App. Total	Left	Thru	Right	Peds	App. Total	
Peak Hour Analysis From 07:00 to 08:45 - Peak 1 of 1																					
Peak Hour for Entire Intersection Begins at 07:00																					
07:00	0	0	0	0	0	0	147	25	0	172	33	17	7	0	57	21	20	0	0	41	270
07:15	0	0	0	0	0	0	185	26	0	211	31	17	9	0	57	12	40	0	0	52	320
07:30	0	0	0	0	0	0	227	27	0	254	35	18	12	0	65	18	39	0	0	57	376
07:45	0	0	0	0	0	0	161	21	0	182	43	20	12	0	75	21	38	0	0	59	316
Total Volume	0	0	0	0	0	0	720	99	0	819	142	72	40	0	254	72	137	0	0	209	1282
% App. Total	0	0	0	0	0	0	87.9	12.1	0	87.9	55.9	28.3	15.7	0	55.9	34.4	65.6	0	0	34.4	87.9
PHF	.000	.000	.000	.000	.000	.000	.793	.917	.000	.806	.826	.900	.833	.000	.847	.857	.856	.000	.000	.886	.852

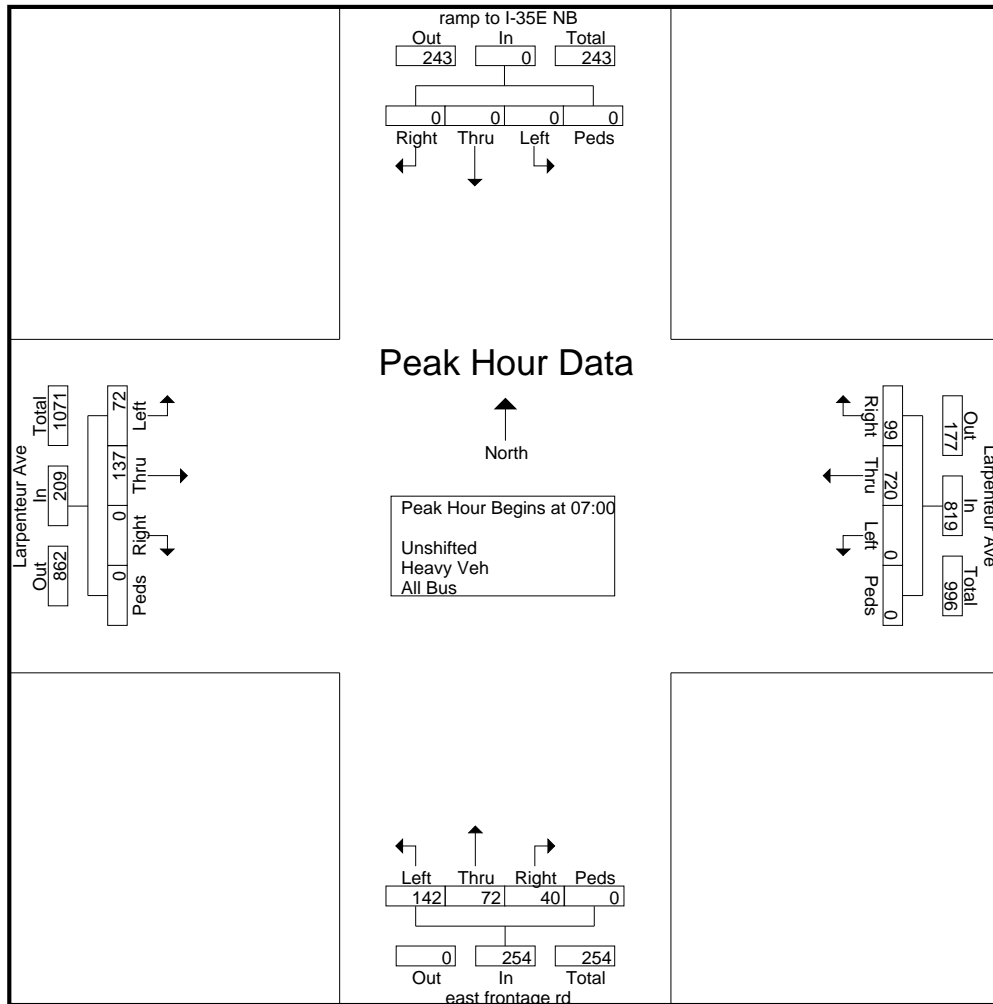

SEH Inc
Traffic Data Collection
TURN MOVEMENT COUNT

I-35E at Larpenteur Avenue, East Ramp
Ref.Pt.: 110.360
SEH Inc
TURN MOVEMENT COUNT

File Name : Larpenteur at NB I-35E Ramp
Site Code : 00000021
Start Date : 3/10/2011
Page No : 3

Start Time	ramp to I-35E NB Southbound					Larpenteur Ave Westbound					east frontage rd Northbound					Larpenteur Ave Eastbound					Int. Total
	Left	Thru	Right	Peds	App. Total	Left	Thru	Right	Peds	App. Total	Left	Thru	Right	Peds	App. Total	Left	Thru	Right	Peds	App. Total	
Peak Hour Analysis From 16:00 to 17:45 - Peak 1 of 1																					
Peak Hour for Entire Intersection Begins at 16:15																					
16:15	0	0	0	0	0	0	75	23	0	98	41	27	24	0	92	51	130	0	0	181	371
16:30	0	0	0	0	0	0	56	23	0	79	37	34	26	0	97	53	134	0	0	187	363
16:45	0	0	0	0	0	0	57	16	0	73	42	24	23	0	89	42	143	0	0	185	347
17:00	0	0	0	0	0	0	59	18	0	77	38	26	17	0	81	53	131	0	0	184	342
Total Volume	0	0	0	0	0	0	247	80	0	327	158	111	90	0	359	199	538	0	0	737	1423
% App. Total	0	0	0	0	0	0	75.5	24.5	0		44	30.9	25.1	0		27	73	0	0		
PHF	.000	.000	.000	.000	.000	.000	.823	.870	.000	.834	.940	.816	.865	.000	.925	.939	.941	.000	.000	.985	.959

