



# MINNESOTA DEPT OF TRANSPORTATION

## TRAFFIC DATA COLLECTION - METRO

I-35W AT CSAH-96, EAST RAMPS  
 REF.PT.: 027.559  
 JAMAR # 632 DR  
 TURN MOVEMENT COUNT

File Name : I-35W AT CSAH-96 EAST RAMPS 2006  
 Site Code : 00000000  
 Start Date : 7/25/2006  
 Page No : 1

### Groups Printed- Cars & Trucks

Start Time	RAMP TO I-35W NB Southbound				CSAH-96 Westbound				RAMP FROM I-35W NB Northbound				CSAH-96 Eastbound				Int. Total
	Left	Thru	Right	Peds	Left	Thru	Right	Peds	Left	Thru	Right	Peds	Left	Thru	Right	Peds	
06:00	0	0	0	0	0	93	8	0	11	0	37	0	2	13	0	0	164
06:15	0	0	0	0	0	123	3	0	19	0	46	0	6	24	0	0	221
06:30	0	0	0	0	0	164	7	0	39	0	75	0	9	38	0	0	332
06:45	0	0	0	0	0	195	5	0	51	0	99	0	17	59	0	0	426
Total	0	0	0	0	0	575	23	0	120	0	257	0	34	134	0	0	1143
07:00	0	0	0	0	0	199	16	0	41	1	75	0	26	63	0	0	421
07:15	0	0	0	0	0	208	12	0	37	0	109	0	21	82	0	0	469
07:30	0	0	0	0	0	220	5	0	42	0	120	0	17	83	0	0	487
07:45	0	0	0	0	0	204	12	0	49	0	130	0	33	107	0	0	535
Total	0	0	0	0	0	831	45	0	169	1	434	0	97	335	0	0	1912
08:00	0	0	0	0	0	178	7	0	37	0	103	0	20	69	0	0	414
08:15	0	0	0	0	0	172	12	0	41	0	107	0	27	65	0	0	424
08:30	0	0	0	0	0	198	17	0	24	0	125	0	36	48	0	0	448
08:45	0	0	0	0	0	148	9	0	51	0	91	0	14	47	0	0	360
Total	0	0	0	0	0	696	45	0	153	0	426	0	97	229	0	0	1646
*** BREAK ***																	
15:00	0	0	0	0	0	162	47	0	23	0	104	0	79	81	0	0	496
15:15	0	0	0	0	0	134	26	0	32	0	113	0	60	77	0	0	442
15:30	0	0	0	0	0	130	27	0	16	1	85	0	70	102	0	0	431
15:45	0	0	0	0	0	122	26	0	12	0	70	0	83	94	0	0	407
Total	0	0	0	0	0	548	126	0	83	1	372	0	292	354	0	0	1776
16:00	0	0	0	0	0	134	27	0	17	0	85	0	89	80	0	0	432
16:15	0	0	0	0	0	133	37	0	16	1	93	0	56	90	0	0	426
16:30	0	0	0	0	0	153	54	0	9	0	96	0	84	123	0	0	519
16:45	0	0	0	0	0	142	47	0	12	0	82	0	57	123	0	0	463
Total	0	0	0	0	0	562	165	0	54	1	356	0	286	416	0	0	1840
17:00	0	0	0	0	0	153	46	0	14	0	85	0	62	127	0	0	487
17:15	0	0	0	0	0	143	42	0	12	1	92	0	58	120	0	0	468
17:30	0	0	0	0	0	125	23	0	21	2	122	0	49	106	0	0	448
17:45	0	0	0	0	0	141	22	0	11	1	129	0	55	69	0	0	428
Total	0	0	0	0	0	562	133	0	58	4	428	0	224	422	0	0	1831
Grand Total	0	0	0	0	0	3774	537	0	637	7	2273	0	1030	1890	0	0	10148
Approch %	0	0	0	0	0	87.5	12.5	0	21.8	0.2	77.9	0	35.3	64.7	0	0	
Total %	0	0	0	0	0	37.2	5.3	0	6.3	0.1	22.4	0	10.1	18.6	0	0	



# MINNESOTA DEPT OF TRANSPORTATION

TRAFFIC DATA COLLECTION - METRO

I-35W AT CSAH-96, EAST RAMPS  
 REF.PT.: 027.559  
 JAMAR # 632 DR  
 TURN MOVEMENT COUNT

File Name : I-35W AT CSAH-96 EAST RAMPS 2006  
 Site Code : 00000000  
 Start Date : 7/25/2006  
 Page No : 2

Start Time	RAMP TO I-35W NB Southbound					CSAH-96 Westbound					RAMP FROM I-35W NB Northbound					CSAH-96 Eastbound					Int. Total
	Left	Thru	Right	Peds	App. Total	Left	Thru	Right	Peds	App. Total	Left	Thru	Right	Peds	App. Total	Left	Thru	Right	Peds	App. Total	
Peak Hour Analysis From 06:00 to 08:45 - Peak 1 of 1																					
Peak Hour for Entire Intersection Begins at 07:00																					
07:00	0	0	0	0	0	0	199	16	0	215	41	1	75	0	117	26	63	0	0	89	421
07:15	0	0	0	0	0	0	208	12	0	220	37	0	109	0	146	21	82	0	0	103	469
07:30	0	0	0	0	0	0	220	5	0	225	42	0	120	0	162	17	83	0	0	100	487
07:45	0	0	0	0	0	0	204	12	0	216	49	0	130	0	179	33	107	0	0	140	535
Total Volume	0	0	0	0	0	0	831	45	0	876	169	1	434	0	604	97	335	0	0	432	1912
% App. Total	0	0	0	0	0	0	94.9	5.1	0		28	0.2	71.9	0		22.5	77.5	0	0		
PHF	.000	.000	.000	.000	.000	.000	.944	.703	.000	.973	.862	.250	.835	.000	.844	.735	.783	.000	.000	.771	.893

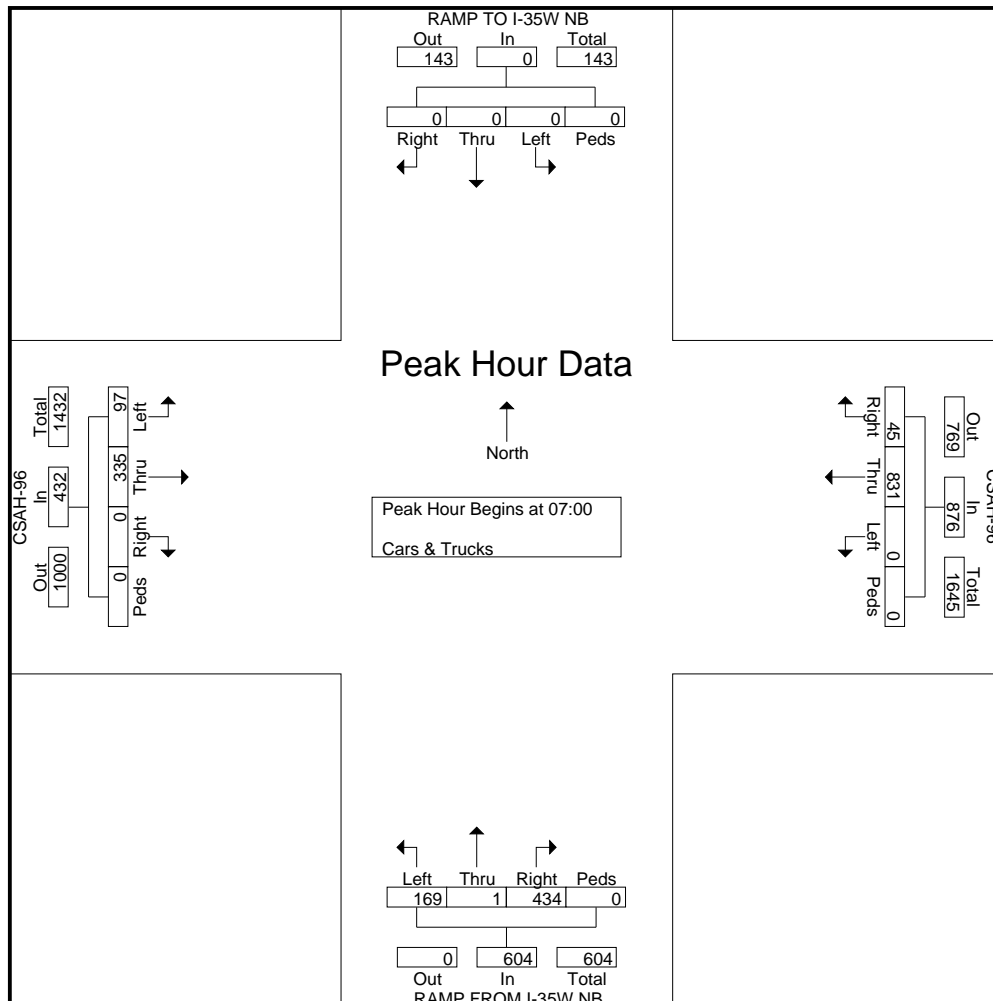



# MINNESOTA DEPT OF TRANSPORTATION

## TRAFFIC DATA COLLECTION - METRO

I-35W AT CSAH-96, EAST RAMPS  
 REF.PT.: 027.559  
 JAMAR # 632 DR  
 TURN MOVEMENT COUNT

File Name : I-35W AT CSAH-96 EAST RAMPS 2006  
 Site Code : 00000000  
 Start Date : 7/25/2006  
 Page No : 3

Start Time	RAMP TO I-35W NB Southbound					CSAH-96 Westbound					RAMP FROM I-35W NB Northbound					CSAH-96 Eastbound					Int. Total
	Left	Thru	Right	Peds	App. Total	Left	Thru	Right	Peds	App. Total	Left	Thru	Right	Peds	App. Total	Left	Thru	Right	Peds	App. Total	
Peak Hour Analysis From 13:00 to 17:45 - Peak 1 of 1																					
Peak Hour for Entire Intersection Begins at 16:30																					
16:30	0	0	0	0	0	0	153	54	0	207	9	0	96	0	105	84	123	0	0	207	519
16:45	0	0	0	0	0	0	142	47	0	189	12	0	82	0	94	57	123	0	0	180	463
17:00	0	0	0	0	0	0	153	46	0	199	14	0	85	0	99	62	127	0	0	189	487
17:15	0	0	0	0	0	0	143	42	0	185	12	1	92	0	105	58	120	0	0	178	468
Total Volume	0	0	0	0	0	0	591	189	0	780	47	1	355	0	403	261	493	0	0	754	1937
% App. Total	0	0	0	0	0	0	75.8	24.2	0	11.7	0.2	88.1	0	34.6	65.4	0	0	0	0	9.11	9.33
PHF	.000	.000	.000	.000	.000	.000	.966	.875	.000	.942	.839	.250	.924	.000	.960	.777	.970	.000	.000	.911	.933

