

Albeck Gerken, Inc

Transportation Engineers

Traffic Data Collection

Park Place Blvd at Gamble Drive

Ref.Pt.: St Louis Park

Data by: Albeck Gerkin Inc

TURN MOVEMENT COUNT

File Name : Park Place Blvd at Gamble Dr 2007

Site Code : 00182717

Start Date : 4/10/2007

Page No : 1

Groups Printed- Unshifted

Start Time	Park Place Blvd Southbound				Gamble Drive Westbound				Park Place Blvd Northbound				commercial road Eastbound				Int. Total
	Left	Thru	Right	Peds	Left	Thru	Right	Peds	Left	Thru	Right	Peds	Left	Thru	Right	Peds	
06:00	14	21	8	0	2	0	1	0	12	15	6	0	8	0	4	0	91
06:15	14	15	8	0	0	1	1	0	9	22	8	0	6	1	8	0	93
06:30	27	14	10	0	0	0	3	0	16	25	20	0	5	5	7	0	132
06:45	46	19	20	0	10	6	6	0	15	25	30	0	13	12	10	0	212
Total	101	69	46	0	12	7	11	0	52	87	64	0	32	18	29	0	528
07:00	52	25	17	0	1	3	4	0	21	57	46	0	9	9	6	0	250
07:15	68	27	17	0	0	1	5	0	21	45	62	0	22	6	14	0	288
07:30	75	22	14	1	2	1	7	0	42	54	67	0	19	15	14	0	333
07:45	80	29	16	0	3	1	9	0	41	70	101	0	22	19	17	0	408
Total	275	103	64	1	6	6	25	0	125	226	276	0	72	49	51	0	1279
08:00	107	30	21	0	5	1	7	1	27	47	72	0	19	15	19	1	372
08:15	83	30	15	1	5	2	9	1	24	64	107	2	19	14	15	0	391
08:30	64	29	34	0	8	2	10	0	26	42	58	0	17	5	18	0	313
08:45	54	33	27	0	11	6	14	0	30	34	50	0	26	10	20	0	315
Total	308	122	97	1	29	11	40	2	107	187	287	2	81	44	72	1	1391
*** BREAK ***																	
11:00	36	38	33	0	10	10	48	0	68	49	15	0	35	6	49	2	399
11:15	26	53	35	0	17	17	38	0	63	55	16	1	37	6	43	2	409
11:30	28	60	34	1	17	13	50	1	68	42	13	0	25	5	38	0	395
11:45	28	57	45	0	19	13	29	0	89	52	17	1	41	9	59	2	461
Total	118	208	147	1	63	53	165	1	288	198	61	2	138	26	189	6	1664
12:00	25	45	37	4	19	14	53	3	70	47	16	1	39	20	62	0	455
12:15	42	38	54	0	17	19	43	1	81	51	19	2	42	14	50	3	476
12:30	39	51	43	0	11	7	54	0	71	62	20	1	40	12	64	0	475
12:45	52	63	39	2	14	15	32	0	60	44	33	1	51	13	63	0	482
Total	158	197	173	6	61	55	182	4	282	204	88	5	172	59	239	3	1888
*** BREAK ***																	
15:00	20	33	25	0	16	10	51	0	48	33	11	1	44	6	44	1	343
15:15	30	33	34	0	13	9	43	0	46	25	14	0	28	12	54	0	341
15:30	20	42	33	0	23	7	64	0	56	25	5	0	32	6	41	0	354
15:45	12	56	27	0	16	11	51	0	50	40	13	0	35	5	55	0	371
Total	82	164	119	0	68	37	209	0	200	123	43	1	139	29	194	1	1409
16:00	6	65	29	0	33	6	76	0	42	57	11	0	28	10	43	0	406
16:15	17	76	28	0	25	4	60	1	53	36	9	0	29	4	32	0	374
16:30	19	74	26	0	30	6	74	1	52	57	21	0	27	9	33	0	429
16:45	17	92	28	0	48	7	82	1	54	51	10	0	32	7	39	0	468
Total	59	307	111	0	136	23	292	3	201	201	51	0	116	30	147	0	1677
17:00	12	90	25	1	59	11	92	1	51	56	12	0	27	10	45	0	492
17:15	19	104	24	0	37	9	83	0	69	50	8	0	44	4	50	0	501
17:30	10	86	17	0	50	7	83	0	57	52	5	0	25	5	52	0	449
17:45	14	72	27	0	28	8	55	0	62	38	6	0	29	4	46	0	389
Total	55	352	93	1	174	35	313	1	239	196	31	0	125	23	193	0	1831
Grand Total	1156	1522	850	10	549	227	1237	11	1494	1422	901	10	875	278	1114	11	11667
Apprch %	32.7	43	24	0.3	27.1	11.2	61.1	0.5	39	37.2	23.5	0.3	38.4	12.2	48.9	0.5	
Total %	9.9	13	7.3	0.1	4.7	1.9	10.6	0.1	12.8	12.2	7.7	0.1	7.5	2.4	9.5	0.1	

Albeck Gerken, Inc

Transportation Engineers

Traffic Data Collection

Park Place Blvd at Gamble Drive
 Ref.Pt.: St Louis Park
 Data by: Albeck Gerkin Inc
 TURN MOVEMENT COUNT

File Name : Park Place Blvd at Gamble Dr 2007
 Site Code : 00182717
 Start Date : 4/10/2007
 Page No : 2

Start Time	Park Place Blvd Southbound					Gamble Drive Westbound					Park Place Blvd Northbound					commercial road Eastbound					Int. Total
	Left	Thru	Right	Peds	App. Total	Left	Thru	Right	Peds	App. Total	Left	Thru	Right	Peds	App. Total	Left	Thru	Right	Peds	App. Total	
Peak Hour Analysis From 06:00 to 08:45 - Peak 1 of 1																					
Peak Hour for Entire Intersection Begins at 07:30																					
07:30	75	22	14	1	112	2	1	7	0	10	42	54	67	0	163	19	15	14	0	48	333
07:45	80	29	16	0	125	3	1	9	0	13	41	70	101	0	212	22	19	17	0	58	408
08:00	107	30	21	0	158	5	1	7	1	14	27	47	72	0	146	19	15	19	1	54	372
08:15	83	30	15	1	129	5	2	9	1	17	24	64	107	2	197	19	14	15	0	48	391
Total Volume	345	111	66	2	524	15	5	32	2	54	134	235	347	2	718	79	63	65	1	208	1504
% App. Total	65.8	21.2	12.6	0.4		27.8	9.3	59.3	3.7		18.7	32.7	48.3	0.3		38	30.3	31.2	0.5		
PHF	.806	.925	.786	.500	.829	.750	.625	.889	.500	.794	.798	.839	.811	.250	.847	.898	.829	.855	.250	.897	.922

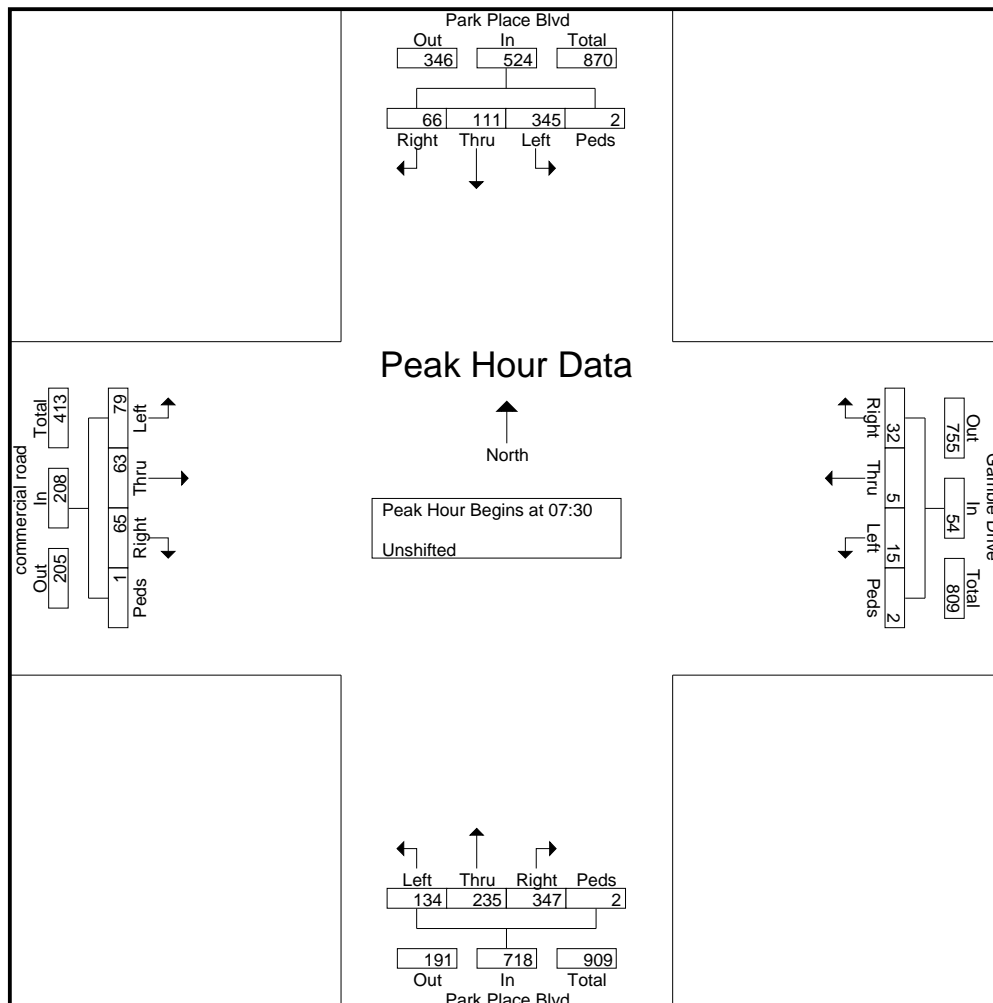

Albeck Gerken, Inc

Transportation Engineers

Traffic Data Collection

Park Place Blvd at Gamble Drive
 Ref.Pt.: St Louis Park
 Data by: Albeck Gerkin Inc
 TURN MOVEMENT COUNT

File Name : Park Place Blvd at Gamble Dr 2007
 Site Code : 00182717
 Start Date : 4/10/2007
 Page No : 3

Start Time	Park Place Blvd Southbound					Gamble Drive Westbound					Park Place Blvd Northbound					commercial road Eastbound					Int. Total
	Left	Thru	Right	Peds	App. Total	Left	Thru	Right	Peds	App. Total	Left	Thru	Right	Peds	App. Total	Left	Thru	Right	Peds	App. Total	
Peak Hour Analysis From 15:00 to 17:45 - Peak 1 of 1																					
Peak Hour for Entire Intersection Begins at 16:45																					
16:45	17	92	28	0	137	48	7	82	1	138	54	51	10	0	115	32	7	39	0	78	468
17:00	12	90	25	1	128	59	11	92	1	163	51	56	12	0	119	27	10	45	0	82	492
17:15	19	104	24	0	147	37	9	83	0	129	69	50	8	0	127	44	4	50	0	98	501
17:30	10	86	17	0	113	50	7	83	0	140	57	52	5	0	114	25	5	52	0	82	449
Total Volume	58	372	94	1	525	194	34	340	2	570	231	209	35	0	475	128	26	186	0	340	1910
% App. Total	11	70.9	17.9	0.2		34	6	59.6	0.4		48.6	44	7.4	0		37.6	7.6	54.7	0		
PHF	.763	.894	.839	.250	.893	.822	.773	.924	.500	.874	.837	.933	.729	.000	.935	.727	.650	.894	.000	.867	.953

