



MINNESOTA DEPT OF TRANSPORTATION

TRAFFIC DATA COLLECTION - METRO

I-494 at Nicollet Ave., South Ramps
 Ref.Pt.: 004.357
 JAMAR # T-2638 CAH
 TURN MOVEMENT COUNT

File Name : I-494 at Nicollet Ave south ramps 2010
 Site Code : 00000000
 Start Date : 10/13/2010
 Page No : 1

Groups Printed- Cars & Trucks

Start Time	NICOLLET AVE. Southbound				ramp to I-494 EB Westbound				NICOLLET AVE. Northbound				ramp from I-494 EB Eastbound				Int. Total
	Left	Thru	Right	Peds	Left	Thru	Right	Peds	Left	Thru	Right	Peds	Left	Thru	Right	Peds	
06:00	11	51	0	0	0	0	0	0	1	59	18	0	4	0	12	0	156
06:15	18	74	0	0	0	0	0	0	0	43	24	4	14	0	30	0	207
06:30	20	81	0	2	0	0	0	0	0	67	44	0	7	0	35	0	256
06:45	12	79	0	1	0	0	0	0	0	73	34	0	17	2	50	0	268
Total	61	285	0	3	0	0	0	0	1	242	120	4	42	2	127	0	887
07:00	24	84	0	0	0	0	0	0	0	87	44	2	31	0	34	0	306
07:15	29	68	0	0	0	0	0	0	0	104	47	0	32	0	41	0	321
07:30	26	77	0	0	0	0	0	0	0	101	47	1	23	0	31	0	306
07:45	40	85	0	0	0	0	0	0	0	105	36	1	22	0	37	0	326
Total	119	314	0	0	0	0	0	0	0	397	174	4	108	0	143	0	1259
08:00	22	67	0	1	0	0	0	0	0	87	42	0	13	0	35	0	267
08:15	23	78	0	0	0	0	0	0	0	74	25	0	20	0	29	0	249
08:30	32	80	0	0	0	0	0	0	0	96	33	0	13	0	35	0	289
08:45	21	81	0	0	0	0	0	0	0	82	39	1	21	0	41	0	286
Total	98	306	0	1	0	0	0	0	0	339	139	1	67	0	140	0	1091
*** BREAK ***																	
15:00	33	139	0	0	0	0	0	0	0	143	62	2	33	1	24	0	437
15:15	20	134	0	0	0	0	0	0	0	135	65	1	29	0	28	0	412
15:30	32	146	0	0	0	0	0	0	0	127	81	3	19	0	27	0	435
15:45	20	155	0	0	0	0	0	0	0	149	60	1	16	0	45	0	446
Total	105	574	0	0	0	0	0	0	0	554	268	7	97	1	124	0	1730
16:00	47	150	0	1	0	0	0	0	0	117	76	1	36	0	25	0	453
16:15	34	131	0	0	0	0	0	0	0	134	81	1	25	0	32	0	438
16:30	51	120	0	0	0	0	0	0	0	142	85	2	26	0	46	0	472
16:45	44	139	0	0	0	0	0	0	0	147	74	0	22	0	28	0	454
Total	176	540	0	1	0	0	0	0	0	540	316	4	109	0	131	0	1817
17:00	42	140	0	1	0	0	0	0	0	148	66	3	23	0	30	0	453
17:15	40	114	0	3	0	0	0	0	0	146	70	0	14	1	25	0	413
17:30	51	149	0	0	0	0	0	0	0	123	49	1	26	0	23	0	422
17:45	36	155	0	1	0	0	0	0	0	112	50	0	34	2	25	0	415
Total	169	558	0	5	0	0	0	0	0	529	235	4	97	3	103	0	1703
Grand Total	728	2577	0	10	0	0	0	0	1	2601	1252	24	520	6	768	0	8487
Apprch %	22	77.7	0	0.3	0	0	0	0	0	67.1	32.3	0.6	40.2	0.5	59.4	0	
Total %	8.6	30.4	0	0.1	0	0	0	0	0	30.6	14.8	0.3	6.1	0.1	9	0	



MINNESOTA DEPT OF TRANSPORTATION

TRAFFIC DATA COLLECTION - METRO

I-494 at Nicollet Ave., South Ramps
 Ref.Pt.: 004.357
 JAMAR # T-2638 CAH
 TURN MOVEMENT COUNT

File Name : I-494 at Nicollet Ave south ramps 2010
 Site Code : 00000000
 Start Date : 10/13/2010
 Page No : 2

Start Time	NICOLLET AVE. Southbound					ramp to I-494 EB Westbound					NICOLLET AVE. Northbound					ramp from I-494 EB Eastbound					Int. Total
	Left	Thru	Right	Peds	App. Total	Left	Thru	Right	Peds	App. Total	Left	Thru	Right	Peds	App. Total	Left	Thru	Right	Peds	App. Total	
Peak Hour Analysis From 06:00 to 08:45 - Peak 1 of 1																					
Peak Hour for Entire Intersection Begins at 07:00																					
07:00	24	84	0	0	108	0	0	0	0	0	0	87	44	2	133	31	0	34	0	65	306
07:15	29	68	0	0	97	0	0	0	0	0	0	104	47	0	151	32	0	41	0	73	321
07:30	26	77	0	0	103	0	0	0	0	0	0	101	47	1	149	23	0	31	0	54	306
07:45	40	85	0	0	125	0	0	0	0	0	0	105	36	1	142	22	0	37	0	59	326
Total Volume	119	314	0	0	433	0	0	0	0	0	0	397	174	4	575	108	0	143	0	251	1259
% App. Total	27.5	72.5	0	0		0	0	0	0		0	69	30.3	0.7		43	0	57	0		
PHF	.744	.924	.000	.000	.866	.000	.000	.000	.000	.000	.000	.945	.926	.500	.952	.844	.000	.872	.000	.860	.965

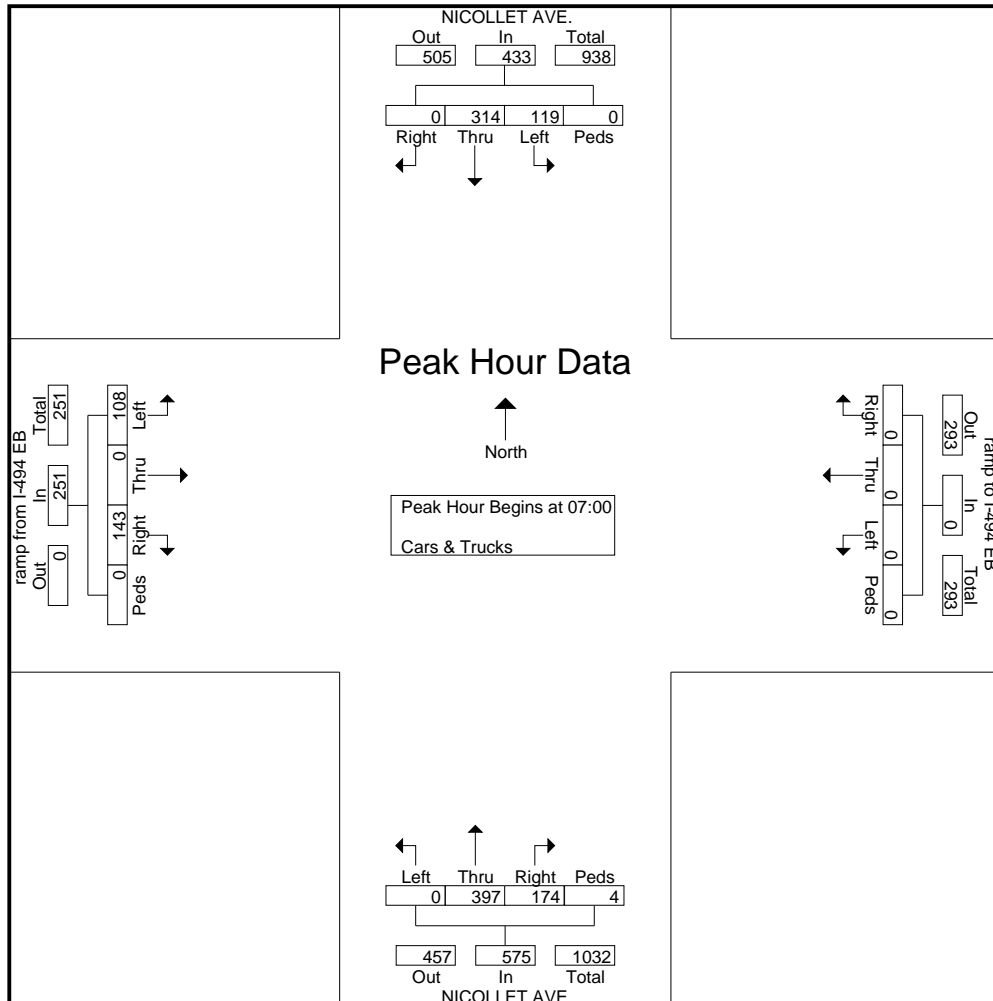



MINNESOTA DEPT OF TRANSPORTATION

TRAFFIC DATA COLLECTION - METRO

I-494 at Nicollet Ave., South Ramps
 Ref.Pt.: 004.357
 JAMAR # T-2638 CAH
 TURN MOVEMENT COUNT

File Name : I-494 at Nicollet Ave south ramps 2010
 Site Code : 00000000
 Start Date : 10/13/2010
 Page No : 3

Start Time	NICOLLET AVE. Southbound					ramp to I-494 EB Westbound					NICOLLET AVE. Northbound					ramp from I-494 EB Eastbound					Int. Total
	Left	Thru	Right	Peds	App. Total	Left	Thru	Right	Peds	App. Total	Left	Thru	Right	Peds	App. Total	Left	Thru	Right	Peds	App. Total	

Peak Hour Analysis From 15:00 to 17:45 - Peak 1 of 1
 Peak Hour for Entire Intersection Begins at 16:00

16:00	47	150	0	1	198	0	0	0	0	0	0	117	76	1	194	36	0	25	0	61	453
16:15	34	131	0	0	165	0	0	0	0	0	0	134	81	1	216	25	0	32	0	57	438
16:30	51	120	0	0	171	0	0	0	0	0	0	142	85	2	229	26	0	46	0	72	472
16:45	44	139	0	0	183	0	0	0	0	0	0	147	74	0	221	22	0	28	0	50	454
Total Volume	176	540	0	1	717	0	0	0	0	0	0	540	316	4	860	109	0	131	0	240	1817
% App. Total	24.5	75.3	0	0.1		0	0	0	0		0	62.8	36.7	0.5		45.4	0	54.6	0		
PHF	.863	.900	.000	.250	.905	.000	.000	.000	.000	.000	.000	.918	.929	.500	.939	.757	.000	.712	.000	.833	.962

