

Albeck Gerken, Inc

Transportation Engineers

Traffic Data Collection

I-494 at Lake Road, east ramps WOODBURY
 Ref.Pt.: 060.720
 JAMAR # 631 RE
 TURN MOVEMENT COUNT

File Name : 20 I-494 East Ramp at Lake Rd
 Site Code : 20
 Start Date : 4/10/2012
 Page No : 1

Groups Printed- Cars - Heavy Vehicles

Start Time	Wooddale Drive Southbound				Lake Rd Westbound				ramp from / loop to I-494 NB Northbound				Lake Rd Eastbound				Int. Total
	Left	Thru	Right	Peds	Left	Thru	Right	Peds	Left	Thru	Right	Peds	Left	Thru	Right	Peds	
06:00	0	0	2	0	43	84	1	0	19	12	7	0	3	18	5	0	194
06:15	0	0	1	0	45	124	2	0	32	8	5	0	2	33	10	0	262
06:30	2	5	6	0	60	177	3	0	40	15	4	0	3	20	9	0	344
06:45	0	0	4	0	61	166	5	0	96	23	3	0	5	34	32	0	429
Total	2	5	13	0	209	551	11	0	187	58	19	0	13	105	56	0	1229
07:00	4	6	2	0	79	182	6	0	36	4	5	0	16	47	22	0	409
07:15	0	2	2	0	62	235	4	0	57	38	1	0	15	61	28	0	505
07:30	0	1	3	0	88	267	5	0	71	24	1	0	11	50	34	0	555
07:45	0	1	7	0	74	220	15	0	75	55	1	0	21	60	30	0	559
Total	4	10	14	0	303	904	30	0	239	121	8	0	63	218	114	0	2028
08:00	2	3	6	0	51	179	1	0	64	32	12	0	13	45	29	0	437
08:15	1	2	5	0	67	214	11	0	42	22	10	0	21	47	14	0	456
08:30	3	4	3	1	55	127	3	1	63	7	11	0	9	52	19	0	358
08:45	3	4	12	0	58	105	7	0	67	28	12	0	16	38	24	0	374
Total	9	13	26	1	231	625	22	1	236	89	45	0	59	182	86	0	1625
09:00	2	1	8	0	42	104	3	0	39	15	18	0	18	44	26	0	320
09:15	1	6	5	1	30	89	6	0	45	19	14	0	11	51	18	0	296
09:30	3	0	4	0	46	67	6	1	40	16	11	0	10	49	22	0	275
09:45	3	3	9	0	24	79	6	0	34	14	16	0	4	36	18	0	246
Total	9	10	26	1	142	339	21	1	158	64	59	0	43	180	84	0	1137
10:00	1	2	6	0	23	60	6	0	30	12	25	0	7	52	15	0	239
10:15	0	9	6	0	25	54	3	0	33	6	16	0	8	41	20	0	221
10:30	3	7	5	0	33	55	8	0	42	9	21	0	6	47	26	0	262
10:45	3	5	4	1	11	73	9	0	37	9	26	0	8	57	24	0	267
Total	7	23	21	1	92	242	26	0	142	36	88	0	29	197	85	0	989
11:00	4	8	8	0	24	57	4	0	42	2	18	0	8	57	29	0	261
11:15	5	8	9	0	38	62	0	0	36	4	10	0	6	57	25	0	260
11:30	6	2	4	0	31	54	2	0	33	6	16	0	5	58	29	0	246
11:45	13	2	9	0	25	66	7	0	23	8	29	0	8	63	23	0	276
Total	28	20	30	0	118	239	13	0	134	20	73	0	27	235	106	0	1043
12:00	6	4	7	0	26	65	10	0	24	9	19	0	9	72	20	0	271
12:15	3	10	5	0	23	57	7	0	26	5	29	0	9	63	33	0	270
12:30	5	7	4	0	27	64	7	0	31	4	22	0	9	55	19	0	254
12:45	5	9	3	0	20	72	7	0	43	7	21	0	8	62	16	0	273
Total	19	30	19	0	96	258	31	0	124	25	91	0	35	252	88	0	1068
13:00	4	2	8	1	29	83	6	0	32	9	24	0	7	67	28	0	300
13:15	5	4	4	0	25	42	5	0	36	4	25	1	16	65	22	0	254
13:30	5	4	3	0	26	52	7	0	33	9	29	0	11	49	18	0	246
13:45	7	2	6	0	31	59	5	0	41	8	23	0	13	71	22	0	288
Total	21	12	21	1	111	236	23	0	142	30	101	1	47	252	90	0	1088
14:00	3	6	4	0	23	62	6	0	31	7	39	0	12	63	26	0	282
14:15	3	1	2	0	21	80	4	0	40	12	40	0	11	88	26	0	328
14:30	5	8	1	0	29	62	2	0	44	5	40	0	9	76	24	0	305
14:45	4	6	6	1	34	83	4	0	47	6	40	0	5	96	22	0	354
Total	15	21	13	1	107	287	16	0	162	30	159	0	37	323	98	0	1269
15:00	9	7	6	0	18	70	6	0	30	7	30	1	7	90	29	0	310
15:15	8	10	6	0	34	72	5	0	46	4	68	0	10	104	24	0	391
15:30	7	20	21	0	40	94	4	0	41	6	60	0	6	98	30	0	427
15:45	3	6	5	0	21	86	9	0	46	11	56	0	4	122	33	0	402
Total	27	43	38	0	113	322	24	0	163	28	214	1	27	414	116	0	1530

Albeck Gerken, Inc

Transportation Engineers

Traffic Data Collection

I-494 at Lake Road, east ramps WOODBURY
 Ref.Pt.: 060.720
 JAMAR # 631 RE
 TURN MOVEMENT COUNT

File Name : 20 I-494 East Ramp at Lake Rd
 Site Code : 20
 Start Date : 4/10/2012
 Page No : 2

Groups Printed- Cars - Heavy Vehicles

Start Time	Wooddale Drive Southbound				Lake Rd Westbound				ramp from / loop to I-494 NB Northbound				Lake Rd Eastbound				Int. Total
	Left	Thru	Right	Peds	Left	Thru	Right	Peds	Left	Thru	Right	Peds	Left	Thru	Right	Peds	
16:00	8	14	6	0	37	96	7	0	54	10	73	0	5	128	25	0	463
16:15	4	13	15	0	24	86	8	0	47	7	71	0	9	155	24	0	463
16:30	6	21	16	0	21	68	5	0	50	1	62	0	3	136	40	0	429
16:45	10	17	7	0	24	86	6	0	46	9	100	0	7	175	39	0	526
Total	28	65	44	0	106	336	26	0	197	27	306	0	24	594	128	0	1881
17:00	8	22	29	0	35	63	4	0	53	9	109	0	8	179	48	0	567
17:15	10	7	25	0	40	87	19	0	52	11	125	0	9	165	32	0	582
17:30	27	10	20	0	29	94	7	2	37	6	144	0	6	167	23	0	572
17:45	16	7	8	0	32	79	12	0	49	18	101	1	19	136	26	0	504
Total	61	46	82	0	136	323	42	2	191	44	479	1	42	647	129	0	2225
18:00	7	3	16	0	38	74	11	0	29	3	114	0	7	130	15	0	447
18:15	6	5	8	0	28	59	4	0	25	8	75	0	9	126	22	0	375
18:30	13	4	11	0	28	65	5	0	29	2	62	0	7	96	29	0	351
18:45	4	2	7	0	22	68	6	1	35	5	54	0	3	105	16	0	328
Total	30	14	42	0	116	266	26	1	118	18	305	0	26	457	82	0	1501
Grand Total	260	312	389	5	1880	4928	311	5	2193	590	1947	3	472	4056	1262	0	18613
Apprch %	26.9	32.3	40.3	0.5	26.4	69.2	4.4	0.1	46.3	12.5	41.1	0.1	8.2	70.1	21.8	0	
Total %	1.4	1.7	2.1	0	10.1	26.5	1.7	0	11.8	3.2	10.5	0	2.5	21.8	6.8	0	
Cars	251	260	327	5	1842	4855	304	4	2145	519	1884	3	436	3975	1235	0	18045
% Cars	96.5	83.3	84.1	100	98	98.5	97.7	80	97.8	88	96.8	100	92.4	98	97.9	0	96.9
Heavy Vehicles	9	52	62	0	38	73	7	1	48	71	63	0	36	81	27	0	568
% Heavy Vehicles	3.5	16.7	15.9	0	2	1.5	2.3	20	2.2	12	3.2	0	7.6	2	2.1	0	3.1

Albeck Gerken, Inc

Transportation Engineers

Traffic Data Collection

I-494 at Lake Road, east ramps WOODBURY

Ref.Pt.: 060.720

JAMAR # 631 RE

TURN MOVEMENT COUNT

File Name : 20 I-494 East Ramp at Lake Rd

Site Code : 20

Start Date : 4/10/2012

Page No : 3

Start Time	Wooddale Drive Southbound					Lake Rd Westbound					ramp from / loop to I-494 NB Northbound					Lake Rd Eastbound					Int. Total
	Left	Thru	Right	Peds	App. Total	Left	Thru	Right	Peds	App. Total	Left	Thru	Right	Peds	App. Total	Left	Thru	Right	Peds	App. Total	
Peak Hour Analysis From 06:00 to 08:00 - Peak 1 of 1																					
Peak Hour for Entire Intersection Begins at 07:15																					
07:15	0	2	2	0	4	62	235	4	0	301	57	38	1	0	96	15	61	28	0	104	505
07:30	0	1	3	0	4	88	267	5	0	360	71	24	1	0	96	11	50	34	0	95	555
07:45	0	1	7	0	8	74	220	15	0	309	75	55	1	0	131	21	60	30	0	111	559
08:00	2	3	6	0	11	51	179	1	0	231	64	32	12	0	108	13	45	29	0	87	437
Total Volume	2	7	18	0	27	275	901	25	0	1201	267	149	15	0	431	60	216	121	0	397	2056
% App. Total	7.4	25.9	66.7	0		22.9	75	2.1	0		61.9	34.6	3.5	0		15.1	54.4	30.5	0		
PHF	.250	.583	.643	.000	.614	.781	.844	.417	.000	.834	.890	.677	.313	.000	.823	.714	.885	.890	.000	.894	.919

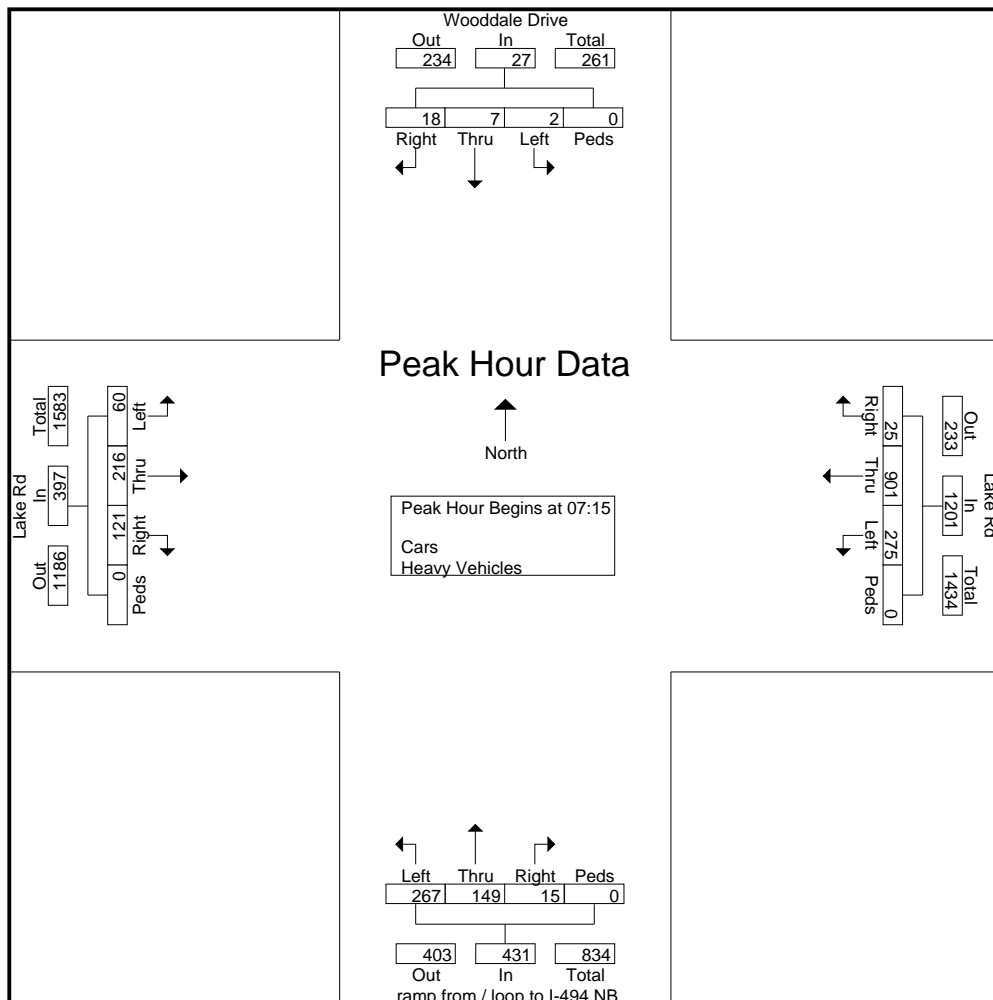

Albeck Gerken, Inc

Transportation Engineers

Traffic Data Collection

I-494 at Lake Road, east ramps WOODBURY

Ref.Pt.: 060.720

JAMAR # 631 RE

TURN MOVEMENT COUNT

File Name : 20 I-494 East Ramp at Lake Rd

Site Code : 20

Start Date : 4/10/2012

Page No : 4

Start Time	Wooddale Drive Southbound					Lake Rd Westbound					ramp from / loop to I-494 NB Northbound					Lake Rd Eastbound					Int. Total
	Left	Thru	Right	Peds	App. Total	Left	Thru	Right	Peds	App. Total	Left	Thru	Right	Peds	App. Total	Left	Thru	Right	Peds	App. Total	
Peak Hour Analysis From 12:45 to 18:45 - Peak 1 of 1																					
Peak Hour for Entire Intersection Begins at 16:45																					
16:45	10	17	7	0	34	24	86	6	0	116	46	9	100	0	155	7	175	39	0	221	526
17:00	8	22	29	0	59	35	63	4	0	102	53	9	109	0	171	8	179	48	0	235	567
17:15	10	7	25	0	42	40	87	19	0	146	52	11	125	0	188	9	165	32	0	206	582
17:30	27	10	20	0	57	29	94	7	2	132	37	6	144	0	187	6	167	23	0	196	572
Total Volume	55	56	81	0	192	128	330	36	2	496	188	35	478	0	701	30	686	142	0	858	2247
% App. Total	28.6	29.2	42.2	0		25.8	66.5	7.3	0.4		26.8	5	68.2	0		3.5	80	16.6	0		
PHF	.509	.636	.698	.000	.814	.800	.878	.474	.250	.849	.887	.795	.830	.000	.932	.833	.958	.740	.000	.913	.965

