

Alliant Engineering

Minneapolis, MN 55415

--TRAFFIC DATA --

I-94 at Boone Ave., North Ramps

Ref.Pt.: 219.520

Alliant Eng.

TURN MOVEMENT COUNT

File Name : 502_I-94 & Boone Ave N Ramp

Site Code : 502

Start Date : 3/8/2016

Page No : 1

Groups Printed- Vehicles - Trucks

Start Time	Boone Ave Southbound				I-94, North Ramp Westbound				Boone Ave Northbound				I-94, North Ramp Eastbound				Int. Total
	Left	Thru	Rght	Other	Left	Thru	Rght	Other	Left	Thru	Rght	Other	Left	Thru	Rght	Other	
06:00	6	31	1	0	9	24	27	0	16	20	18	0	0	2	7	0	161
06:15	5	35	1	0	24	27	36	0	13	30	23	0	0	1	15	0	210
06:30	3	32	0	0	41	37	36	0	25	39	24	0	0	2	14	0	253
06:45	2	37	1	0	48	68	39	0	40	47	15	0	0	4	16	0	317
Total	16	135	3	0	122	156	138	0	94	136	80	0	0	9	52	0	941
07:00	1	43	0	0	49	61	40	0	42	65	21	0	1	3	7	0	333
07:15	3	59	0	0	30	64	45	0	49	74	20	0	0	10	13	0	367
07:30	7	60	2	0	44	74	45	0	59	73	31	0	1	23	26	0	445
07:45	4	42	0	0	45	75	54	0	57	67	12	0	2	32	41	0	431
Total	15	204	2	0	168	274	184	0	207	279	84	0	4	68	87	0	1576
08:00	5	35	3	0	41	52	68	0	39	63	18	0	1	8	28	0	361
08:15	8	39	0	0	50	48	57	0	35	64	35	0	1	5	5	0	347
08:30	7	28	0	0	32	27	41	0	28	64	27	1	0	9	12	0	276
08:45	9	44	1	0	25	46	43	0	33	63	24	0	0	9	11	0	308
Total	29	146	4	0	148	173	209	0	135	254	104	1	2	31	56	0	1292
09:00	5	36	0	0	25	28	52	0	22	59	19	0	3	10	13	0	272
09:15	8	30	0	0	25	21	30	0	30	63	30	0	0	6	13	0	256
*** BREAK ***																	
Total	13	66	0	0	50	49	82	0	52	122	49	0	3	16	26	0	528
*** BREAK ***																	
10:30	13	35	0	0	18	16	19	0	17	47	20	0	0	10	15	0	210
10:45	9	50	0	0	25	8	25	0	14	46	22	0	0	9	21	0	229
Total	22	85	0	0	43	24	44	0	31	93	42	0	0	19	36	0	439
11:00	28	44	2	0	24	19	19	0	12	44	31	0	0	11	34	0	268
11:15	11	43	1	0	16	11	26	0	12	69	27	0	1	24	33	0	274
11:30	21	55	2	0	13	7	19	0	10	61	29	0	2	40	57	0	316
11:45	23	67	1	0	26	19	25	1	16	64	30	0	0	18	29	0	319
Total	83	209	6	0	79	56	89	1	50	238	117	0	3	93	153	0	1177
12:00	23	68	0	0	15	9	19	0	19	76	30	0	1	26	44	0	330
12:15	20	43	0	0	21	18	25	0	27	62	24	0	0	12	22	0	274
12:30	15	52	1	0	21	14	24	0	21	82	25	0	1	11	18	0	285
12:45	11	42	2	0	20	19	33	0	30	75	31	0	0	9	15	0	287
Total	69	205	3	0	77	60	101	0	97	295	110	0	2	58	99	0	1176
13:00	12	61	0	0	30	31	30	0	30	50	21	0	1	11	21	0	298
13:15	14	52	0	0	29	29	18	0	22	54	15	0	2	5	23	0	263
*** BREAK ***																	
Total	26	113	0	0	59	60	48	0	52	104	36	0	3	16	44	0	561
*** BREAK ***																	
14:30	20	117	1	0	32	27	22	0	16	48	38	0	3	47	44	0	415
14:45	21	74	1	0	40	28	28	0	27	61	33	0	1	38	40	0	392
Total	41	191	2	0	72	55	50	0	43	109	71	0	4	85	84	0	807
15:00	34	70	0	0	38	25	25	0	10	62	35	0	0	54	45	0	398
15:15	31	55	0	0	39	16	14	0	15	70	25	0	2	26	40	0	333
15:30	40	124	1	0	38	14	27	0	6	64	47	0	0	60	70	0	491
15:45	33	72	0	0	43	11	18	0	18	73	48	0	0	24	27	0	367
Total	138	321	1	0	158	66	84	0	49	269	155	0	2	164	182	0	1589
16:00	54	101	0	0	45	15	28	0	21	78	39	0	0	47	54	0	482
16:15	48	88	0	0	50	13	11	0	9	67	21	0	0	37	41	0	385
16:30	49	112	0	0	30	14	19	0	8	77	31	0	1	62	58	0	461

Alliant Engineering

Minneapolis, MN 55415

--TRAFFIC DATA --

I-94 at Boone Ave., North Ramps

Ref.Pt.: 219.520

Alliant Eng.

TURN MOVEMENT COUNT

File Name : 502_I-94 & Boone Ave N Ramp

Site Code : 502

Start Date : 3/8/2016

Page No : 2

Groups Printed- Vehicles - Trucks

Start Time	Boone Ave Southbound				I-94, North Ramp Westbound				Boone Ave Northbound				I-94, North Ramp Eastbound				Int. Total
	Left	Thru	Rght	Other	Left	Thru	Rght	Other	Left	Thru	Rght	Other	Left	Thru	Rght	Other	
16:45	43	95	0	0	58	14	23	0	4	69	28	0	1	34	45	0	414
Total	194	396	0	0	183	56	81	0	42	291	119	0	2	180	198	0	1742
17:00	50	109	0	0	51	9	9	0	13	53	45	0	0	47	70	0	456
17:15	34	82	0	0	44	12	17	0	14	70	21	0	0	35	40	0	369
17:30	23	42	0	0	28	17	13	0	12	60	28	0	2	23	40	0	288
17:45	14	45	0	0	40	11	15	0	10	37	22	0	0	13	24	0	231
Total	121	278	0	0	163	49	54	0	49	220	116	0	2	118	174	0	1344
Grand Total	767	2349	21	0	1322	1078	1164	1	901	2410	1083	1	27	857	1191	0	13172
Apprch %	24.5	74.9	0.7	0	37.1	30.2	32.7	0	20.5	54.8	24.6	0	1.3	41.3	57.4	0	
Total %	5.8	17.8	0.2	0	10	8.2	8.8	0	6.8	18.3	8.2	0	0.2	6.5	9	0	
Vehicles	718	2252	21	0	1266	1019	1119	1	841	2297	1049	1	21	805	1123	0	12533
% Vehicles	93.6	95.9	100	0	95.8	94.5	96.1	100	93.3	95.3	96.9	100	77.8	93.9	94.3	0	95.1
Trucks	49	97	0	0	56	59	45	0	60	113	34	0	6	52	68	0	639
% Trucks	6.4	4.1	0	0	4.2	5.5	3.9	0	6.7	4.7	3.1	0	22.2	6.1	5.7	0	4.9

Alliant Engineering

Minneapolis, MN 55415

--TRAFFIC DATA --

I-94 at Boone Ave., North Ramps

Ref.Pt.: 219.520

Alliant Eng.

TURN MOVEMENT COUNT

File Name : 502_I-94 & Boone Ave N Ramp

Site Code : 502

Start Date : 3/8/2016

Page No : 3

Start Time	Boone Ave Southbound					I-94, North Ramp Westbound					Boone Ave Northbound					I-94, North Ramp Eastbound					Int. Total
	Left	Thru	Right	Other	App. Total	Left	Thru	Right	Other	App. Total	Left	Thru	Right	Other	App. Total	Left	Thru	Right	Other	App. Total	
Peak Hour Analysis From 06:00 to 11:45 - Peak 1 of 1																					
Peak Hour for Entire Intersection Begins at 07:15																					
07:15	3	59	0	0	62	30	64	45	0	139	49	74	20	0	143	0	10	13	0	23	367
07:30	7	60	2	0	69	44	74	45	0	163	59	73	31	0	163	1	23	26	0	50	445
07:45	4	42	0	0	46	45	75	54	0	174	57	67	12	0	136	2	32	41	0	75	431
08:00	5	35	3	0	43	41	52	68	0	161	39	63	18	0	120	1	8	28	0	37	361
Total Volume	19	196	5	0	220	160	265	212	0	637	204	277	81	0	562	4	73	108	0	185	1604
% App. Total	8.6	89.1	2.3	0		25.1	41.6	33.3	0		36.3	49.3	14.4	0		2.2	39.5	58.4	0		
PHF	.679	.817	.417	.000	.797	.889	.883	.779	.000	.915	.864	.936	.653	.000	.862	.500	.570	.659	.000	.617	.901

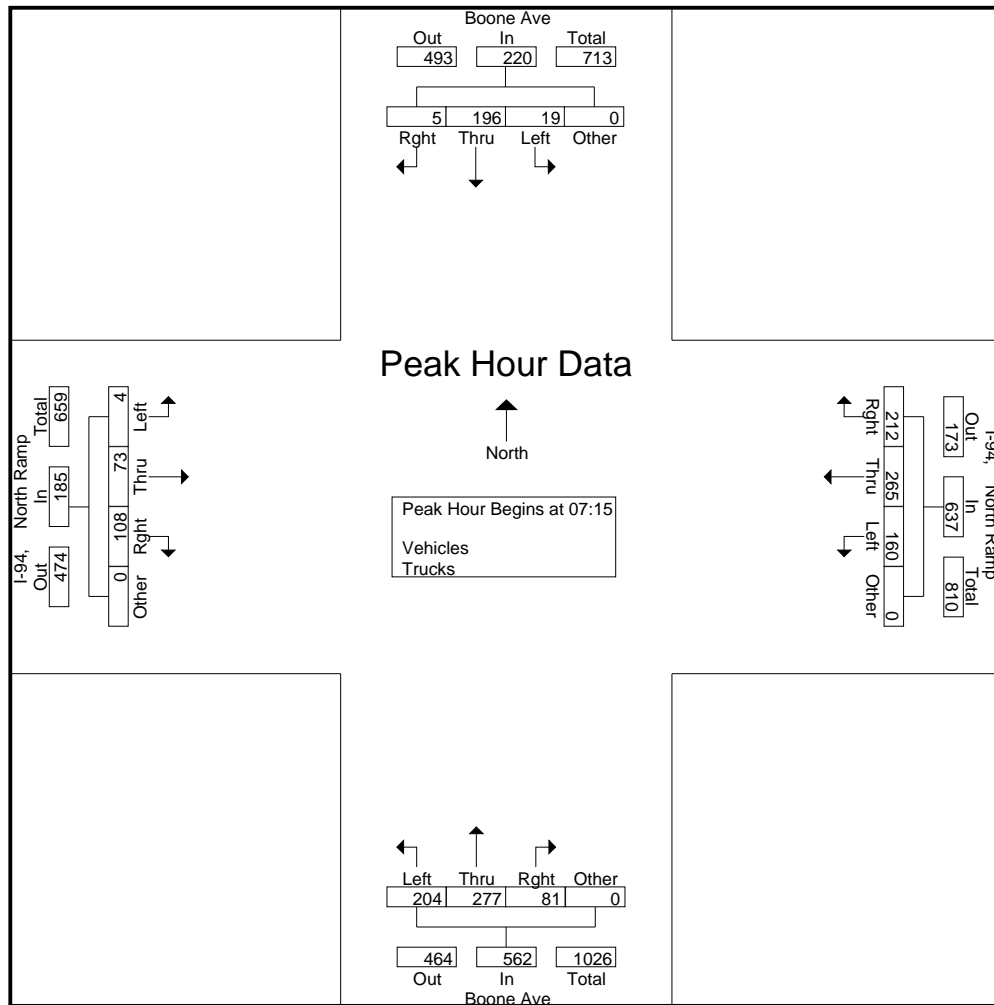

Alliant Engineering

Minneapolis, MN 55415

--TRAFFIC DATA --

I-94 at Boone Ave., North Ramps

Ref.Pt.: 219.520

Alliant Eng.

TURN MOVEMENT COUNT

File Name : 502_I-94 & Boone Ave N Ramp

Site Code : 502

Start Date : 3/8/2016

Page No : 4

Start Time	Boone Ave Southbound					I-94, North Ramp Westbound					Boone Ave Northbound					I-94, North Ramp Eastbound					Int. Total
	Left	Thru	Rght	Other	App. Total	Left	Thru	Rght	Other	App. Total	Left	Thru	Rght	Other	App. Total	Left	Thru	Rght	Other	App. Total	
Peak Hour Analysis From 12:00 to 17:45 - Peak 1 of 1																					
Peak Hour for Entire Intersection Begins at 16:00																					
16:00	54	101	0	0	155	45	15	28	0	88	21	78	39	0	138	0	47	54	0	101	482
16:15	48	88	0	0	136	50	13	11	0	74	9	67	21	0	97	0	37	41	0	78	385
16:30	49	112	0	0	161	30	14	19	0	63	8	77	31	0	116	1	62	58	0	121	461
16:45	43	95	0	0	138	58	14	23	0	95	4	69	28	0	101	1	34	45	0	80	414
Total Volume	194	396	0	0	590	183	56	81	0	320	42	291	119	0	452	2	180	198	0	380	1742
% App. Total	32.9	67.1	0	0		57.2	17.5	25.3	0		9.3	64.4	26.3	0		0.5	47.4	52.1	0		
PHF	.898	.884	.000	.000	.916	.789	.933	.723	.000	.842	.500	.933	.763	.000	.819	.500	.726	.853	.000	.785	.904

