

Associated Consulting Services (ACS)  
 Roseville, MN 55113  
 -- TRAFFIC DATA --

TH-94 at 49th Ave [West ramp]  
 Data Prepared By: ACS  
 TURNING MOVEMENT COUNT

File Name : TH-94 at 49th Ave [West ramp]\_2021  
 Site Code :  
 Start Date : 10/6/2021  
 Page No : 1

Groups Printed- Cars - Trucks

Start Time	W. Lyndale Ave Southbound				49th Ave Westbound				N. Lyndale Ave Northbound				49th Ave Eastbound				Int. Total
	Left	Thru	Right	Peds	Left	Thru	Right	Peds	Left	Thru	Right	Peds	Left	Thru	Right	Peds	
06:00	0	21	6	0	8	8	0	0	3	0	6	0	0	5	23	0	80
06:15	0	27	8	0	5	12	0	0	0	0	10	0	0	3	22	0	87
06:30	0	21	6	0	11	15	0	0	2	0	13	0	0	5	35	0	108
06:45	0	21	5	0	8	34	0	0	2	0	17	0	0	12	24	0	123
Total	0	90	25	0	32	69	0	0	7	0	46	0	0	25	104	0	398
07:00	0	23	8	0	16	30	0	0	9	0	8	0	0	15	30	0	139
07:15	1	26	6	0	14	46	0	0	3	0	28	0	0	8	50	0	182
07:30	0	32	7	0	15	34	0	0	4	0	18	0	0	18	51	0	179
07:45	1	27	17	0	11	33	0	0	5	0	22	0	0	15	42	0	173
Total	2	108	38	0	56	143	0	0	21	0	76	0	0	56	173	0	673
08:00	0	26	10	0	14	41	0	0	12	0	23	0	0	12	45	0	183
08:15	1	31	7	0	20	38	0	0	11	0	15	0	0	10	36	0	169
08:30	1	13	9	0	16	43	0	0	4	0	16	0	0	7	48	0	157
08:45	1	43	4	0	18	35	0	0	4	0	24	0	0	15	46	0	190
Total	3	113	30	0	68	157	0	0	31	0	78	0	0	44	175	0	699
09:00	0	61	5	1	15	40	0	0	14	0	33	0	0	13	36	1	219
09:15	1	67	8	1	21	21	0	0	19	0	29	0	0	8	21	0	196
09:30	4	57	7	0	15	33	0	0	22	0	21	0	0	10	32	0	201
09:45	1	66	12	0	15	19	0	0	12	0	26	0	0	9	28	1	189
Total	6	251	32	2	66	113	0	0	67	0	109	0	0	40	117	2	805
10:00	3	45	8	0	13	28	0	0	25	0	30	0	0	6	24	0	182
10:15	1	55	12	0	15	35	0	0	18	0	47	0	0	19	31	0	233
10:30	1	46	3	2	13	23	0	0	17	0	36	0	0	19	31	0	191
10:45	3	55	5	1	15	36	0	0	17	0	39	0	0	10	25	0	206
Total	8	201	28	3	56	122	0	0	77	0	152	0	0	54	111	0	812
11:00	1	48	6	1	20	24	0	0	18	0	38	1	0	14	20	0	191
11:15	1	68	13	1	18	37	0	0	31	0	52	0	0	7	24	0	252
11:30	4	57	7	1	17	22	0	0	19	0	47	0	0	13	33	0	220
11:45	4	52	11	0	17	37	0	0	27	0	34	0	0	15	21	1	219
Total	10	225	37	3	72	120	0	0	95	0	171	1	0	49	98	1	882
12:00	1	55	8	1	17	41	0	0	23	0	27	0	0	12	22	0	207
12:15	0	53	12	1	11	42	0	0	20	0	25	0	0	12	23	1	200
12:30	0	63	1	6	16	39	0	0	10	0	24	1	0	15	37	0	212
12:45	0	64	15	0	16	32	0	0	19	0	32	2	0	11	24	0	215
Total	1	235	36	8	60	154	0	0	72	0	108	3	0	50	106	1	834
13:00	5	35	15	0	11	34	0	0	15	0	27	4	0	22	31	0	199
13:15	1	41	10	0	15	29	0	0	13	0	21	0	0	16	36	1	183
13:30	0	20	13	0	18	41	0	0	16	0	18	0	0	13	26	0	165
13:45	0	34	10	0	18	37	0	0	18	0	28	0	0	12	25	0	182
Total	6	130	48	0	62	141	0	0	62	0	94	4	0	63	118	1	729
14:00	0	35	11	0	16	33	0	0	13	0	16	0	0	8	21	1	154
14:15	3	33	13	0	26	38	0	0	16	0	43	0	0	19	38	0	229
14:30	1	39	20	0	18	42	0	0	12	0	52	0	0	16	31	0	231
14:45	0	41	7	0	24	32	0	0	18	0	35	0	0	26	28	0	211
Total	4	148	51	0	84	145	0	0	59	0	146	0	0	69	118	1	825

Associated Consulting Services (ACS)  
 Roseville, MN 55113  
 -- TRAFFIC DATA --

TH-94 at 49th Ave [West ramp]  
 Data Prepared By: ACS  
 TURNING MOVEMENT COUNT

File Name : TH-94 at 49th Ave [West ramp]\_2021  
 Site Code :  
 Start Date : 10/6/2021  
 Page No : 2

Groups Printed- Cars - Trucks

Start Time	W. Lyndale Ave Southbound				49th Ave Westbound				N. Lyndale Ave Northbound				49th Ave Eastbound				Int. Total
	Left	Thru	Right	Peds	Left	Thru	Right	Peds	Left	Thru	Right	Peds	Left	Thru	Right	Peds	
15:00	0	36	13	1	22	40	0	0	14	0	36	0	0	10	37	0	209
15:15	1	33	14	1	15	49	0	0	22	0	38	1	0	16	43	0	233
15:30	3	39	14	1	25	60	0	0	13	0	46	0	0	14	51	2	268
15:45	0	32	4	0	13	50	0	0	25	0	29	0	0	17	32	2	204
Total	4	140	45	3	75	199	0	0	74	0	149	1	0	57	163	4	914
16:00	0	31	16	0	20	47	0	0	19	0	43	1	0	14	33	0	224
16:15	2	34	6	0	18	53	0	0	10	0	34	1	0	20	36	0	214
16:30	4	34	12	0	18	48	0	0	25	0	39	0	0	14	43	0	237
16:45	0	50	8	3	25	53	0	0	20	0	24	0	0	17	40	0	240
Total	6	149	42	3	81	201	0	0	74	0	140	2	0	65	152	0	915
17:00	1	43	11	3	16	54	0	0	17	0	19	0	0	9	50	1	224
17:15	2	37	12	1	13	50	0	0	19	0	26	2	0	12	27	0	201
17:30	0	31	11	2	17	42	0	0	26	0	34	0	0	10	34	0	207
17:45	1	30	9	1	16	49	0	0	20	0	27	0	0	18	39	0	210
Total	4	141	43	7	62	195	0	0	82	0	106	2	0	49	150	1	842
Grand Total	54	1931	455	29	774	1759	0	0	721	0	1375	13	0	621	1585	11	9328
Apprch %	2.2	78.2	18.4	1.2	30.6	69.4	0	0	34.2	0	65.2	0.6	0	28	71.5	0.5	
Total %	0.6	20.7	4.9	0.3	8.3	18.9	0	0	7.7	0	14.7	0.1	0	6.7	17	0.1	
Cars	47	1738	415	29	598	1632	0	0	679	0	1186	13	0	577	1479	11	8404
% Cars	87	90	91.2	100	77.3	92.8	0	0	94.2	0	86.3	100	0	92.9	93.3	100	90.1
Trucks	7	193	40	0	176	127	0	0	42	0	189	0	0	44	106	0	924
% Trucks	13	10	8.8	0	22.7	7.2	0	0	5.8	0	13.7	0	0	7.1	6.7	0	9.9

Associated Consulting Services (ACS)  
 Roseville, MN 55113  
 -- TRAFFIC DATA --

TH-94 at 49th Ave [West ramp]  
 Data Prepared By: ACS  
 TURNING MOVEMENT COUNT

File Name : TH-94 at 49th Ave [West ramp]\_2021  
 Site Code :  
 Start Date : 10/6/2021  
 Page No : 3

Start Time	W. Lyndale Ave Southbound					49th Ave Westbound					N. Lyndale Ave Northbound					49th Ave Eastbound					Int. Total
	Left	Thru	Right	Peds	App. Total	Left	Thru	Right	Peds	App. Total	Left	Thru	Right	Peds	App. Total	Left	Thru	Right	Peds	App. Total	
Peak Hour Analysis From 06:00 to 11:45 - Peak 1 of 1																					
Peak Hour for Entire Intersection Begins at 11:00																					
11:00	1	48	6	1	56	20	24	0	0	44	18	0	38	1	57	0	14	20	0	34	191
11:15	1	68	13	1	83	18	37	0	0	55	31	0	52	0	83	0	7	24	0	31	252
11:30	4	57	7	1	69	17	22	0	0	39	19	0	47	0	66	0	13	33	0	46	220
11:45	4	52	11	0	67	17	37	0	0	54	27	0	34	0	61	0	15	21	1	37	219
Total Volume	10	225	37	3	275	72	120	0	0	192	95	0	171	1	267	0	49	98	1	148	882
% App. Total	3.6	81.8	13.5	1.1		37.5	62.5	0	0		35.6	0	64	0.4		0	33.1	66.2	0.7		
PHF	.625	.827	.712	.750	.828	.900	.811	.000	.000	.873	.766	.000	.822	.250	.804	.000	.817	.742	.250	.804	.875

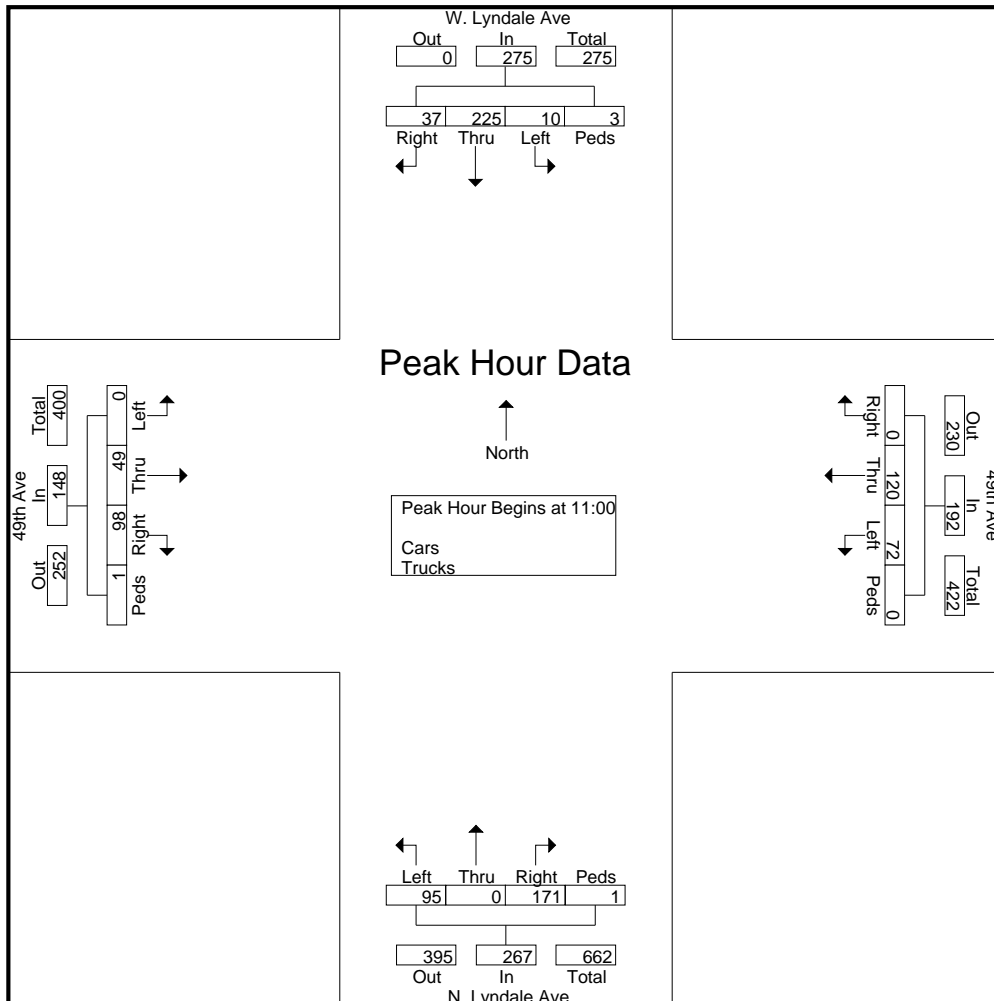

Associated Consulting Services (ACS)  
 Roseville, MN 55113  
 -- TRAFFIC DATA --

TH-94 at 49th Ave [West ramp]  
 Data Prepared By: ACS  
 TURNING MOVEMENT COUNT

File Name : TH-94 at 49th Ave [West ramp]\_2021  
 Site Code :  
 Start Date : 10/6/2021  
 Page No : 4

Start Time	W. Lyndale Ave Southbound					49th Ave Westbound					N. Lyndale Ave Northbound					49th Ave Eastbound					Int. Total
	Left	Thru	Right	Peds	App. Total	Left	Thru	Right	Peds	App. Total	Left	Thru	Right	Peds	App. Total	Left	Thru	Right	Peds	App. Total	
Peak Hour Analysis From 12:00 to 17:45 - Peak 1 of 1																					
Peak Hour for Entire Intersection Begins at 15:15																					
15:15	1	33	14	1	49	15	49	0	0	64	22	0	38	1	61	0	16	43	0	59	233
15:30	3	39	14	1	57	25	60	0	0	85	13	0	46	0	59	0	14	51	2	67	268
15:45	0	32	4	0	36	13	50	0	0	63	25	0	29	0	54	0	17	32	2	51	204
16:00	0	31	16	0	47	20	47	0	0	67	19	0	43	1	63	0	14	33	0	47	224
Total Volume	4	135	48	2	189	73	206	0	0	279	79	0	156	2	237	0	61	159	4	224	929
% App. Total	2.1	71.4	25.4	1.1		26.2	73.8	0	0		33.3	0	65.8	0.8		0	27.2	71	1.8		
PHF	.333	.865	.750	.500	.829	.730	.858	.000	.000	.821	.790	.000	.848	.500	.940	.000	.897	.779	.500	.836	.867

