

# Alliant Engineering Inc Minneapolis, MN 55415

TH-101 at Industrial Blvd  
(S of I-94) ROGERS  
data by Alliant Engineering Inc  
TURN MOVEMENT COUNT

File Name : TH-101 at Industrial Blvd ROGERS 2009  
Site Code : 00000025  
Start Date : 1/22/2009  
Page No : 1

### Groups Printed- Unshifted

Start Time	TH-101 Southbound				Industrial Blvd / CSAH-81 Westbound				Main Street Northbound				Industrial Blvd Eastbound				Int. Total
	Left	Thru	Right	Peds	Left	Thru	Right	Peds	Left	Thru	Right	Peds	Left	Thru	Right	Peds	
06:00	72	63	14	0	2	0	12	0	3	65	3	0	30	7	1	0	272
06:15	117	69	16	0	0	2	8	0	1	59	3	0	45	15	1	0	336
06:30	172	69	10	0	1	3	21	0	2	85	3	0	49	20	2	0	437
06:45	158	86	31	0	4	4	22	0	3	62	6	0	34	16	5	0	431
Total	519	287	71	0	7	9	63	0	9	271	15	0	158	58	9	0	1476
07:00	174	86	16	0	0	8	22	0	1	65	9	0	61	32	0	0	474
07:15	170	100	13	0	3	4	23	0	1	126	12	0	65	36	6	0	559
07:30	165	122	15	0	3	5	28	0	0	92	10	0	59	29	5	0	533
07:45	109	106	23	0	5	4	21	0	3	74	13	0	27	24	9	0	418
Total	618	414	67	0	11	21	94	0	5	357	44	0	212	121	20	0	1984
08:00	118	97	21	0	5	7	15	0	3	53	7	0	26	12	7	0	371
08:15	81	64	12	0	4	6	28	0	1	52	7	0	26	8	6	0	295
08:30	65	50	15	0	3	1	17	0	4	54	9	0	21	9	5	0	253
08:45	63	83	7	0	10	3	29	0	4	84	14	0	23	9	13	0	342
Total	327	294	55	0	22	17	89	0	12	243	37	0	96	38	31	0	1261
09:00	38	51	9	0	7	4	21	0	6	106	14	0	19	6	12	0	293
09:15	41	41	13	0	4	5	28	0	5	66	12	0	24	5	2	0	246
*** BREAK ***																	
Total	79	92	22	0	11	9	49	0	11	172	26	0	43	11	14	0	539
*** BREAK ***																	
10:30	26	42	29	0	3	5	30	0	1	48	14	0	35	10	6	0	249
10:45	20	37	14	0	3	5	33	0	2	42	3	0	21	2	4	0	186
Total	46	79	43	0	6	10	63	0	3	90	17	0	56	12	10	0	435
11:00	34	33	14	0	10	5	41	0	0	59	7	0	19	4	9	0	235
11:15	29	78	7	0	7	2	28	0	2	42	15	0	30	10	9	0	259
11:30	29	73	11	0	7	3	21	0	2	97	5	0	22	9	7	0	286
11:45	20	54	22	0	9	6	42	0	5	69	4	0	28	5	4	0	268
Total	112	238	54	0	33	16	132	0	9	267	31	0	99	28	29	0	1048
12:00	24	54	16	0	15	5	36	0	5	53	7	0	27	6	14	0	262
12:15	38	60	19	0	7	6	24	0	2	65	8	0	13	11	8	0	261
12:30	31	51	27	0	7	6	33	0	4	67	5	0	23	4	5	0	263
12:45	36	67	18	0	14	5	39	0	5	69	8	0	24	3	9	0	297
Total	129	232	80	0	43	22	132	0	16	254	28	0	87	24	36	0	1083
13:00	33	42	22	0	3	8	43	0	1	51	5	0	18	5	10	0	241
13:15	25	61	21	0	3	7	32	0	6	61	9	0	13	6	5	0	249
*** BREAK ***																	
Total	58	103	43	0	6	15	75	0	7	112	14	0	31	11	15	0	490
*** BREAK ***																	
14:30	41	63	24	0	7	9	35	0	1	54	6	0	29	3	7	0	279
14:45	38	77	29	0	11	11	66	0	1	67	1	0	15	4	10	0	330
Total	79	140	53	0	18	20	101	0	2	121	7	0	44	7	17	0	609
15:00	24	71	18	0	19	4	76	0	1	89	7	0	30	8	9	0	356
15:15	38	93	26	0	8	12	85	0	2	87	5	0	27	5	1	0	389
15:30	32	93	46	0	10	15	87	0	5	124	7	0	63	6	10	0	498
15:45	29	76	23	0	17	10	93	0	5	126	4	0	28	3	12	0	426
Total	123	333	113	0	54	41	341	0	13	426	23	0	148	22	32	0	1669

# Alliant Engineering Inc Minneapolis, MN 55415

TH-101 at Industrial Blvd  
(S of I-94) ROGERS  
data by Alliant Engineering Inc  
TURN MOVEMENT COUNT

File Name : TH-101 at Industrial Blvd ROGERS 2009  
Site Code : 00000025  
Start Date : 1/22/2009  
Page No : 2

**Groups Printed- Unshifted**

Start Time	TH-101 Southbound				Industrial Blvd / CSAH-81 Westbound				Main Street Northbound				Industrial Blvd Eastbound				Int. Total
	Left	Thru	Right	Peds	Left	Thru	Right	Peds	Left	Thru	Right	Peds	Left	Thru	Right	Peds	
16:00	29	84	24	0	21	12	119	0	3	120	0	0	69	12	10	0	503
16:15	44	104	35	0	18	11	126	0	3	116	5	0	46	5	12	0	525
16:30	38	96	25	0	19	24	103	0	5	125	7	0	60	9	10	0	521
16:45	39	90	17	0	24	12	114	0	2	132	5	0	58	10	7	0	510
Total	150	374	101	0	82	59	462	0	13	493	17	0	233	36	39	0	2059
17:00	36	85	28	0	20	15	120	0	1	152	6	0	76	10	4	0	553
17:15	44	112	41	0	25	17	140	0	0	136	16	0	55	8	8	0	602
17:30	31	103	23	0	15	22	121	0	5	138	12	0	48	13	2	0	533
17:45	27	119	42	0	18	15	97	0	1	126	15	0	54	10	9	0	533
Total	138	419	134	0	78	69	478	0	7	552	49	0	233	41	23	0	2221
Grand Total	2378	3005	836	0	371	308	2079	0	107	3358	308	0	1440	409	275	0	14874
Apprch %	38.2	48.3	13.4	0	13.5	11.2	75.4	0	2.8	89	8.2	0	67.8	19.3	12.9	0	
Total %	16	20.2	5.6	0	2.5	2.1	14	0	0.7	22.6	2.1	0	9.7	2.7	1.8	0	

# Alliant Engineering Inc Minneapolis, MN 55415

TH-101 at Industrial Blvd  
(S of I-94) ROGERS  
data by Alliant Engineering Inc  
TURN MOVEMENT COUNT

File Name : TH-101 at Industrial Blvd ROGERS 2009  
Site Code : 00000025  
Start Date : 1/22/2009  
Page No : 3

Start Time	TH-101 Southbound					Industrial Blvd / CSAH-81 Westbound					Main Street Northbound					Industrial Blvd Eastbound					Int. Total
	Left	Thru	Right	Peds	App. Total	Left	Thru	Right	Peds	App. Total	Left	Thru	Right	Peds	App. Total	Left	Thru	Right	Peds	App. Total	
Peak Hour Analysis From 06:00 to 08:45 - Peak 1 of 1																					
Peak Hour for Entire Intersection Begins at 06:45																					
06:45	158	86	31	0	275	4	4	22	0	30	3	62	6	0	71	34	16	5	0	55	431
07:00	174	86	16	0	276	0	8	22	0	30	1	65	9	0	75	61	32	0	0	93	474
07:15	170	100	13	0	283	3	4	23	0	30	1	126	12	0	139	65	36	6	0	107	559
07:30	165	122	15	0	302	3	5	28	0	36	0	92	10	0	102	59	29	5	0	93	533
Total Volume	667	394	75	0	1136	10	21	95	0	126	5	345	37	0	387	219	113	16	0	348	1997
% App. Total	58.7	34.7	6.6	0		7.9	16.7	75.4	0		1.3	89.1	9.6	0		62.9	32.5	4.6	0		
PHF	.958	.807	.605	.000	.940	.625	.656	.848	.000	.875	.417	.685	.771	.000	.696	.842	.785	.667	.000	.813	.893

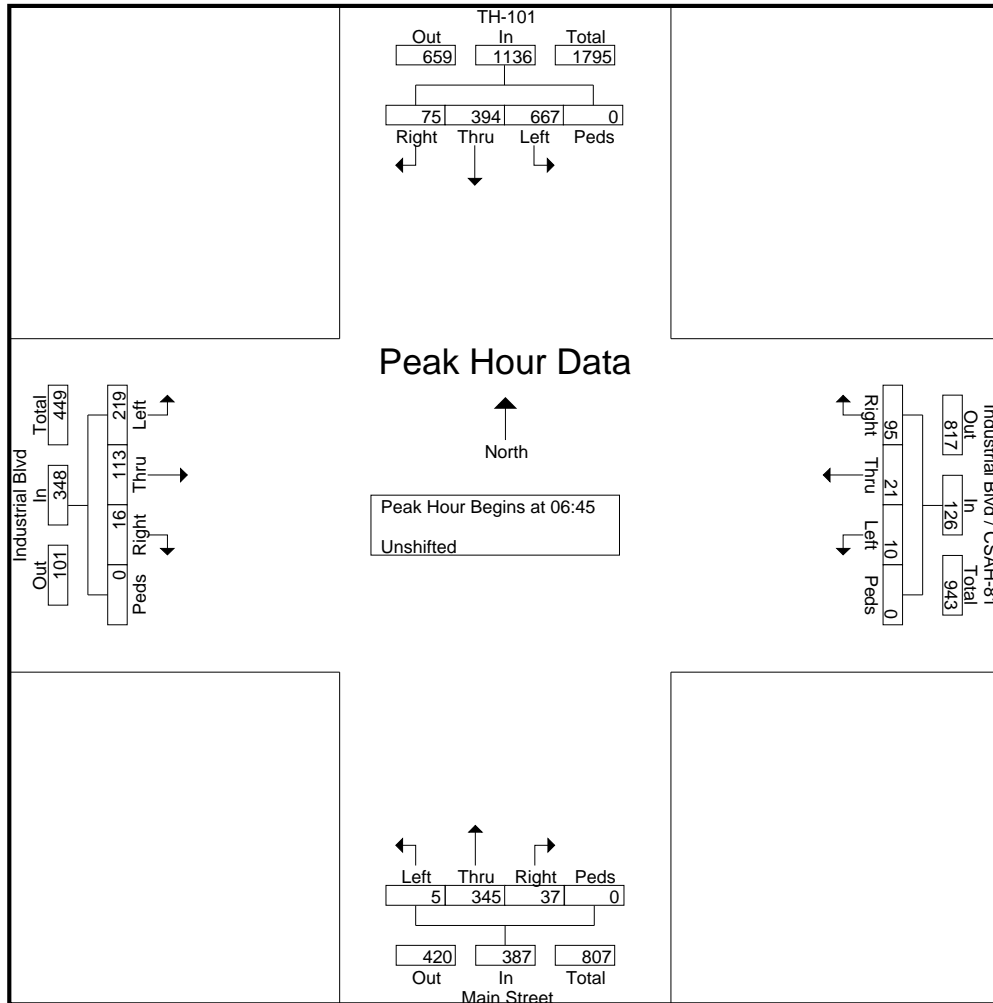

# Alliant Engineering Inc Minneapolis, MN 55415

TH-101 at Industrial Blvd  
(S of I-94) ROGERS  
data by Alliant Engineering Inc  
TURN MOVEMENT COUNT

File Name : TH-101 at Industrial Blvd ROGERS 2009  
Site Code : 00000025  
Start Date : 1/22/2009  
Page No : 4

Start Time	TH-101 Southbound					Industrial Blvd / CSAH-81 Westbound					Main Street Northbound					Industrial Blvd Eastbound					Int. Total
	Left	Thru	Right	Peds	App. Total	Left	Thru	Right	Peds	App. Total	Left	Thru	Right	Peds	App. Total	Left	Thru	Right	Peds	App. Total	
Peak Hour Analysis From 15:00 to 17:45 - Peak 1 of 1																					
Peak Hour for Entire Intersection Begins at 17:00																					
17:00	36	85	28	0	149	20	15	120	0	155	1	152	6	0	159	76	10	4	0	90	553
17:15	44	112	41	0	197	25	17	140	0	182	0	136	16	0	152	55	8	8	0	71	602
17:30	31	103	23	0	157	15	22	121	0	158	5	138	12	0	155	48	13	2	0	63	533
17:45	27	119	42	0	188	18	15	97	0	130	1	126	15	0	142	54	10	9	0	73	533
Total Volume	138	419	134	0	691	78	69	478	0	625	7	552	49	0	608	233	41	23	0	297	2221
% App. Total	20	60.6	19.4	0		12.5	11	76.5	0		1.2	90.8	8.1	0		78.5	13.8	7.7	0		
PHF	.784	.880	.798	.000	.877	.780	.784	.854	.000	.859	.350	.908	.766	.000	.956	.766	.788	.639	.000	.825	.922

