

Alliant Engineering, Inc

233 Park Ave Suite 300
 Minneapolis, MN 55415

--TRAFFIC DATA --

CSAH-83 at TH-169 North Ramp
 Ref.Pt.: 112.713
 data by : Alliant Inc.
 TURN MOVEMENT COUNT

File Name : 344_CSAH 83 & TH 169 N Ramp
 Site Code : 344
 Start Date : 11/8/2017
 Page No : 1

Groups Printed- Vehicles - Trucks

Start Time	CSAH 83 From North				TH 169 N Ramp From East				CSAH 83 From South				TH 169 N Ramp From West				Int. Total
	Other	Left	Thru	Rght	Other	Left	Thru	Rght	Other	Left	Thru	Rght	Other	Left	Thru	Rght	
06:00 AM	0	0	31	23	0	51	0	59	0	9	94	0	0	0	0	0	267
06:15 AM	0	0	39	4	0	61	0	67	0	8	134	0	0	0	0	0	313
06:30 AM	0	0	32	7	0	70	0	67	0	6	144	0	0	0	0	0	326
06:45 AM	0	0	28	8	0	77	0	110	0	7	208	0	0	0	0	0	438
Total	0	0	130	42	0	259	0	303	0	30	580	0	0	0	0	0	1344
07:00 AM	0	0	30	22	0	45	0	94	0	18	170	0	0	0	0	0	379
07:15 AM	0	0	28	22	0	66	0	144	0	17	192	0	0	0	0	0	469
07:30 AM	0	0	37	17	0	67	0	126	0	9	246	0	0	0	0	0	502
07:45 AM	0	0	51	20	0	70	0	148	0	3	294	0	0	0	0	0	586
Total	0	0	146	81	0	248	0	512	0	47	902	0	0	0	0	0	1936
08:00 AM	0	0	34	20	0	56	1	156	1	14	159	0	0	0	0	0	441
08:15 AM	0	0	44	18	0	72	0	152	0	10	120	0	0	0	0	0	416
08:30 AM	0	0	53	10	0	78	0	110	1	13	91	0	0	0	0	0	356
08:45 AM	0	0	54	19	0	78	0	111	0	16	90	0	0	0	0	0	368
Total	0	0	185	67	0	284	1	529	2	53	460	0	0	0	0	0	1581
09:00 AM	0	0	41	25	0	72	0	76	0	8	88	0	0	0	0	0	310
09:15 AM	0	0	41	17	0	105	1	78	0	7	70	0	0	0	0	0	319
*** BREAK ***																	
Total	0	0	82	42	0	177	1	154	0	15	158	0	0	0	0	0	629
*** BREAK ***																	
10:30 AM	0	0	90	23	0	83	0	67	0	9	67	0	0	0	0	0	339
10:45 AM	0	0	90	32	0	85	0	80	0	15	70	0	0	0	0	0	372
Total	0	0	180	55	0	168	0	147	0	24	137	0	0	0	0	0	711
11:00 AM	0	0	96	26	0	99	0	70	0	14	71	0	0	0	0	0	376
11:15 AM	0	0	107	24	0	98	0	71	0	25	82	0	0	0	0	0	407
11:30 AM	0	0	139	40	0	94	0	64	0	12	88	0	0	0	0	0	437
11:45 AM	0	0	117	35	0	126	0	88	0	18	98	0	0	0	0	0	482
Total	0	0	459	125	0	417	0	293	0	69	339	0	0	0	0	0	1702
12:00 PM	0	0	165	46	0	95	0	82	0	24	90	0	0	0	0	0	502
12:15 PM	0	0	141	46	0	90	0	75	0	21	85	0	0	0	0	0	458
12:30 PM	0	0	118	36	0	107	0	113	1	17	107	0	0	0	0	0	499
12:45 PM	0	0	102	33	0	95	0	92	0	11	126	0	0	0	0	0	459
Total	0	0	526	161	0	387	0	362	1	73	408	0	0	0	0	0	1918
01:00 PM	0	0	109	55	0	110	0	85	0	20	82	0	0	0	0	0	461
01:15 PM	0	0	128	29	0	118	0	93	0	12	108	0	0	0	0	0	488
*** BREAK ***																	
Total	0	0	237	84	0	228	0	178	0	32	190	0	0	0	0	0	949
*** BREAK ***																	
02:30 PM	0	0	153	55	0	127	0	74	0	16	90	0	0	0	0	0	515
02:45 PM	0	0	121	31	0	139	0	77	0	16	84	0	0	0	0	0	468
Total	0	0	274	86	0	266	0	151	0	32	174	0	0	0	0	0	983
03:00 PM	0	0	174	87	0	119	0	65	0	20	82	0	0	0	0	0	547
03:15 PM	0	0	155	46	0	150	0	76	0	22	69	0	0	0	0	0	518
03:30 PM	0	0	178	67	0	161	0	67	0	12	82	0	0	0	0	0	567
03:45 PM	0	0	153	55	0	190	0	68	2	13	93	0	0	0	0	0	574
Total	0	0	660	255	0	620	0	276	2	67	326	0	0	0	0	0	2206
04:00 PM	0	0	182	86	0	192	1	67	0	14	72	0	0	0	0	0	614
04:15 PM	0	0	194	45	0	211	1	53	0	26	66	0	0	0	0	0	596
04:30 PM	0	0	193	79	0	184	0	47	0	29	66	0	0	0	0	0	598
04:45 PM	0	0	191	59	0	186	0	48	0	30	70	0	0	0	0	0	584
Total	0	0	760	269	0	773	2	215	0	99	274	0	0	0	0	0	2392

Alliant Engineering, Inc

233 Park Ave Suite 300
 Minneapolis, MN 55415

--TRAFFIC DATA --

CSAH-83 at TH-169 North Ramp
 Ref.Pt.: 112.713
 data by : Alliant Inc.
 TURN MOVEMENT COUNT

File Name : 344_CSAH 83 & TH 169 N Ramp
 Site Code : 344
 Start Date : 11/8/2017
 Page No : 2

Groups Printed- Vehicles - Trucks

Start Time	CSAH 83 From North				TH 169 N Ramp From East				CSAH 83 From South				TH 169 N Ramp From West				Int. Total	
	Other	Left	Thru	Rght	Other	Left	Thru	Rght	Other	Left	Thru	Rght	Other	Left	Thru	Rght		
05:00 PM	0	0	240	80	0	168	2	33	0	39	57	0	0	0	0	0	0	619
05:15 PM	0	0	204	57	0	176	0	51	0	18	77	0	0	0	0	0	0	583
05:30 PM	0	0	169	34	0	184	0	65	0	20	58	0	0	0	0	0	0	530
05:45 PM	0	0	118	33	0	159	0	58	0	25	63	0	0	0	0	0	0	456
Total	0	0	731	204	0	687	2	207	0	102	255	0	0	0	0	0	0	2188
Grand Total	0	0	4370	1471	0	4514	6	3327	5	643	4203	0	0	0	0	0	0	18539
Apprch %	0	0	74.8	25.2	0	57.5	0.1	42.4	0.1	13.3	86.6	0	0	0	0	0	0	
Total %	0	0	23.6	7.9	0	24.3	0	17.9	0	3.5	22.7	0	0	0	0	0	0	
Vehicles	0	0	4029	1292	0	4335	6	3016	5	581	3944	0	0	0	0	0	0	17208
% Vehicles	0	0	92.2	87.8	0	96	100	90.7	100	90.4	93.8	0	0	0	0	0	0	92.8
Trucks	0	0	341	179	0	179	0	311	0	62	259	0	0	0	0	0	0	1331
% Trucks	0	0	7.8	12.2	0	4	0	9.3	0	9.6	6.2	0	0	0	0	0	0	7.2

Alliant Engineering, Inc

233 Park Ave Suite 300
 Minneapolis, MN 55415

--TRAFFIC DATA --

CSAH-83 at TH-169 North Ramp
 Ref.Pt.: 112.713
 data by : Alliant Inc.
 TURN MOVEMENT COUNT

File Name : 344_CSAH 83 & TH 169 N Ramp
 Site Code : 344
 Start Date : 11/8/2017
 Page No : 3

Start Time	CSAH 83 From North					TH 169 N Ramp From East					CSAH 83 From South					TH 169 N Ramp From West					Int. Total
	Other	Left	Thru	Rght	App. Total	Other	Left	Thru	Rght	App. Total	Other	Left	Thru	Rght	App. Total	Other	Left	Thru	Rght	App. Total	
Peak Hour Analysis From 06:00 AM to 11:45 AM - Peak 1 of 1																					
Peak Hour for Entire Intersection Begins at 07:15 AM																					
07:15 AM	0	0	28	22	50	0	66	0	144	210	0	17	192	0	209	0	0	0	0	0	469
07:30 AM	0	0	37	17	54	0	67	0	126	193	0	9	246	0	255	0	0	0	0	0	502
07:45 AM	0	0	51	20	71	0	70	0	148	218	0	3	294	0	297	0	0	0	0	0	586
08:00 AM	0	0	34	20	54	0	56	1	156	213	1	14	159	0	174	0	0	0	0	0	441
Total Volume	0	0	150	79	229	0	259	1	574	834	1	43	891	0	935	0	0	0	0	0	1998
% App. Total	0	0	65.5	34.5		0	31.1	0.1	68.8		0.1	4.6	95.3	0		0	0	0	0		
PHF	.000	.000	.735	.898	.806	.000	.925	.250	.920	.956	.250	.632	.758	.000	.787	.000	.000	.000	.000	.000	.852

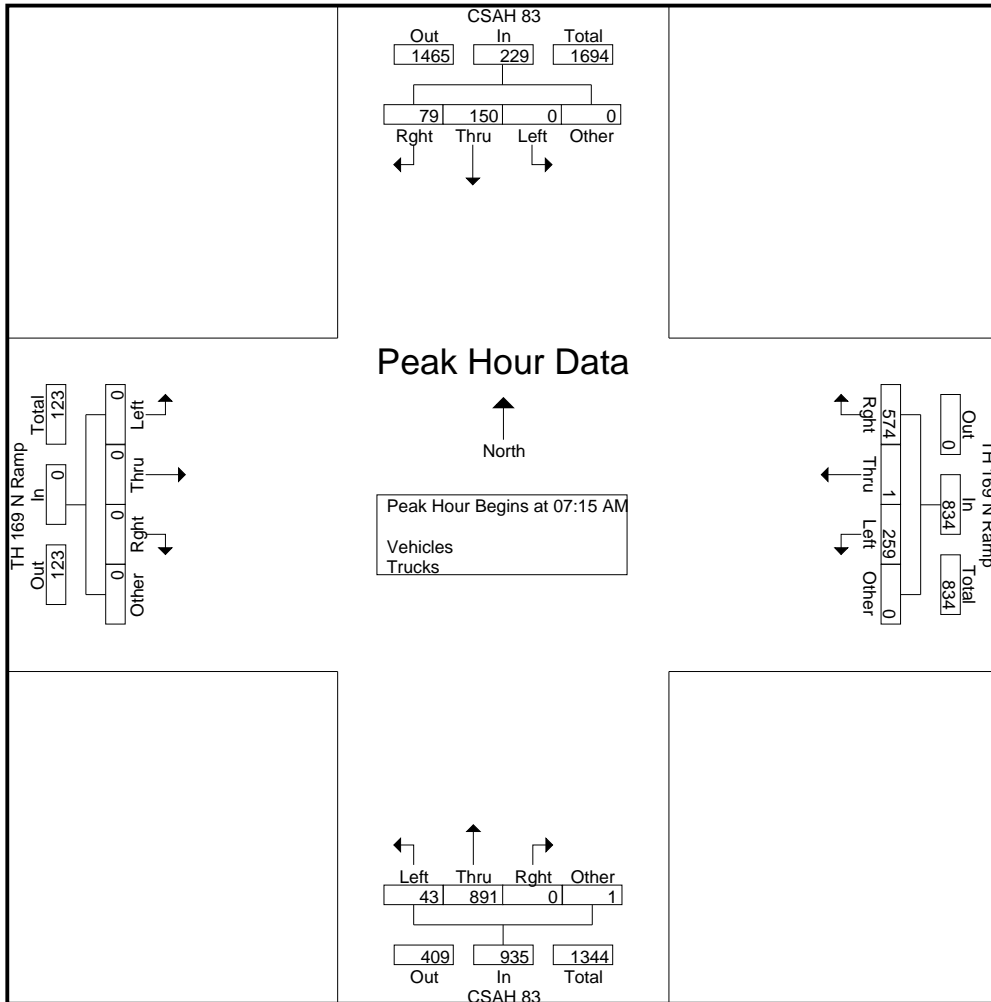

Alliant Engineering, Inc

233 Park Ave Suite 300
 Minneapolis, MN 55415

--TRAFFIC DATA --

CSAH-83 at TH-169 North Ramp
 Ref.Pt.: 112.713
 data by : Alliant Inc.
 TURN MOVEMENT COUNT

File Name : 344_CSAH 83 & TH 169 N Ramp
 Site Code : 344
 Start Date : 11/8/2017
 Page No : 4

Start Time	CSAH 83 From North					TH 169 N Ramp From East					CSAH 83 From South					TH 169 N Ramp From West					Int. Total	
	Other	Left	Thru	Rght	App. Total	Other	Left	Thru	Rght	App. Total	Other	Left	Thru	Rght	App. Total	Other	Left	Thru	Rght	App. Total		
Peak Hour Analysis From 12:00 PM to 05:45 PM - Peak 1 of 1																						
Peak Hour for Entire Intersection Begins at 04:15 PM																						
04:15 PM	0	0	194	45	239	0	211	1	53	265	0	26	66	0	92	0	0	0	0	0	0	596
04:30 PM	0	0	193	79	272	0	184	0	47	231	0	29	66	0	95	0	0	0	0	0	0	598
04:45 PM	0	0	191	59	250	0	186	0	48	234	0	30	70	0	100	0	0	0	0	0	0	584
05:00 PM	0	0	240	80	320	0	168	2	33	203	0	39	57	0	96	0	0	0	0	0	0	619
Total Volume	0	0	818	263	1081	0	749	3	181	933	0	124	259	0	383	0	0	0	0	0	0	2397
% App. Total	0	0	75.7	24.3		0	80.3	0.3	19.4		0	32.4	67.6	0		0	0	0	0	0		
PHF	.000	.000	.852	.822	.845	.000	.887	.375	.854	.880	.000	.795	.925	.000	.958	.000	.000	.000	.000	.000		.968

