



# MINNESOTA DEPT OF TRANSPORTATION

## TRAFFIC DATA COLLECTION - METRO

Loc: ELM CREEK PKWY @ JEFFERSON CT  
 /JEFFERSON HWY 2006  
 REF. PT.:  
 Jamar# 1358/MAR

File Name : ELM CREEK PKWY AT JEFFERSON CT- JEFFERSON HWY 2006  
 Site Code : 00000000  
 Start Date : 6/14/2006  
 Page No : 1

### Groups Printed- Cars & Trucks

Start Time	JEFFERSON CT/JEFFERSON HWY Southbound					ELM CREEK PKWY Westbound					JEFFERSON CT/JEFFERSON HWY Northbound					ELM CREEK PKWY Eastbound					Int. Total
	LEFT	THRU	RIGHT	Peds	App. Total	LEFT	THRU	RIGHT	Peds	App. Total	LEFT	THRU	RIGHT	Peds	App. Total	LEFT	THRU	RIGHT	Peds	App. Total	
06:00	8	7	1	2	18	25	2	9	0	36	3	2	4	0	9	6	41	21	1	69	132
06:15	12	3	0	0	15	32	12	9	0	53	4	3	9	0	16	7	47	41	0	95	179
06:30	19	4	3	0	26	39	13	17	0	69	12	4	7	0	23	9	53	63	0	125	243
06:45	22	13	3	0	38	46	17	13	0	76	13	6	16	0	35	14	66	46	0	126	275
<b>Total</b>	<b>61</b>	<b>27</b>	<b>7</b>	<b>2</b>	<b>97</b>	<b>142</b>	<b>44</b>	<b>48</b>	<b>0</b>	<b>234</b>	<b>32</b>	<b>15</b>	<b>36</b>	<b>0</b>	<b>83</b>	<b>36</b>	<b>207</b>	<b>171</b>	<b>1</b>	<b>415</b>	<b>829</b>
07:00	20	7	4	0	31	47	23	14	0	84	6	6	12	0	24	10	55	70	0	135	274
07:15	17	16	9	1	43	60	33	16	2	111	11	2	16	0	29	14	67	66	1	148	331
07:30	14	15	4	1	34	72	20	31	0	123	9	4	20	0	33	7	80	96	0	183	373
07:45	21	15	9	0	45	75	31	26	0	132	26	10	23	0	59	7	82	89	0	178	414
<b>Total</b>	<b>72</b>	<b>53</b>	<b>26</b>	<b>2</b>	<b>153</b>	<b>254</b>	<b>107</b>	<b>87</b>	<b>2</b>	<b>450</b>	<b>52</b>	<b>22</b>	<b>71</b>	<b>0</b>	<b>145</b>	<b>38</b>	<b>284</b>	<b>321</b>	<b>1</b>	<b>644</b>	<b>1392</b>
08:00	12	11	6	0	29	30	23	27	0	80	14	3	18	0	35	7	54	44	0	105	249
08:15	17	8	8	0	33	33	31	20	0	84	16	9	14	0	39	11	59	26	0	96	252
08:30	20	5	6	0	31	27	21	14	0	62	19	11	24	0	54	6	44	41	0	91	238
08:45	18	7	7	2	34	32	36	13	0	81	23	5	32	0	60	12	44	41	1	98	273
<b>Total</b>	<b>67</b>	<b>31</b>	<b>27</b>	<b>2</b>	<b>127</b>	<b>122</b>	<b>111</b>	<b>74</b>	<b>0</b>	<b>307</b>	<b>72</b>	<b>28</b>	<b>88</b>	<b>0</b>	<b>188</b>	<b>36</b>	<b>201</b>	<b>152</b>	<b>1</b>	<b>390</b>	<b>1012</b>
11:00	16	2	9	0	27	33	53	20	0	106	26	10	36	1	73	5	44	19	1	69	275
11:15	21	8	6	0	35	35	39	18	0	92	24	9	42	0	75	9	64	30	0	103	305
11:30	18	5	3	0	26	48	41	26	0	115	30	13	38	1	82	4	60	32	0	96	319
11:45	18	5	3	0	26	48	47	24	1	120	29	12	43	0	84	6	55	31	0	92	322
<b>Total</b>	<b>73</b>	<b>20</b>	<b>21</b>	<b>0</b>	<b>114</b>	<b>164</b>	<b>180</b>	<b>88</b>	<b>1</b>	<b>433</b>	<b>109</b>	<b>44</b>	<b>159</b>	<b>2</b>	<b>314</b>	<b>24</b>	<b>223</b>	<b>112</b>	<b>1</b>	<b>360</b>	<b>1221</b>
12:00	32	12	2	0	46	47	48	33	0	128	41	17	71	2	131	10	64	27	0	101	406
12:15	23	6	5	1	35	43	46	33	1	123	32	11	53	0	96	9	42	26	3	80	334
12:30	20	4	9	1	34	49	58	30	4	141	23	10	58	1	92	8	39	23	2	72	339
12:45	22	3	6	0	31	45	54	20	0	119	27	7	47	0	81	10	58	38	4	110	341
<b>Total</b>	<b>97</b>	<b>25</b>	<b>22</b>	<b>2</b>	<b>146</b>	<b>184</b>	<b>206</b>	<b>116</b>	<b>5</b>	<b>511</b>	<b>123</b>	<b>45</b>	<b>229</b>	<b>3</b>	<b>400</b>	<b>37</b>	<b>203</b>	<b>114</b>	<b>9</b>	<b>363</b>	<b>1420</b>
15:00	16	24	6	8	54	37	39	20	0	96	43	17	63	0	123	4	39	18	0	61	334
15:15	9	5	7	7	28	31	60	13	0	104	43	16	70	0	129	3	33	25	7	68	329
15:30	13	6	8	3	30	34	83	25	3	145	59	16	68	4	147	7	55	31	1	94	416
15:45	13	4	7	0	24	44	68	30	1	143	78	11	66	2	157	6	57	23	0	86	410
<b>Total</b>	<b>51</b>	<b>39</b>	<b>28</b>	<b>18</b>	<b>136</b>	<b>146</b>	<b>250</b>	<b>88</b>	<b>4</b>	<b>488</b>	<b>223</b>	<b>60</b>	<b>267</b>	<b>6</b>	<b>556</b>	<b>20</b>	<b>184</b>	<b>97</b>	<b>8</b>	<b>309</b>	<b>1489</b>
16:00	13	8	11	5	37	46	85	12	8	151	76	16	105	11	208	6	49	22	1	78	474
16:15	24	2	4	1	31	44	81	36	1	162	88	17	94	2	201	5	71	26	2	104	498
16:30	18	10	8	0	36	48	113	28	0	189	96	12	86	2	196	7	51	21	0	79	500
16:45	16	5	7	10	38	46	113	15	0	174	98	13	94	1	206	10	57	29	2	98	516
<b>Total</b>	<b>71</b>	<b>25</b>	<b>30</b>	<b>16</b>	<b>142</b>	<b>184</b>	<b>392</b>	<b>91</b>	<b>9</b>	<b>676</b>	<b>358</b>	<b>58</b>	<b>379</b>	<b>16</b>	<b>811</b>	<b>28</b>	<b>228</b>	<b>98</b>	<b>5</b>	<b>359</b>	<b>1988</b>
17:00	20	3	7	0	30	46	103	16	1	166	99	20	109	1	229	9	63	26	0	98	523
17:15	27	8	6	1	42	47	96	35	0	178	114	16	81	1	212	3	57	39	1	100	532
17:30	14	5	8	2	29	34	121	11	3	169	85	12	84	2	183	15	84	25	0	124	505
17:45	22	0	5	2	29	35	96	26	0	157	94	29	66	0	189	7	102	35	0	144	519
<b>Total</b>	<b>83</b>	<b>16</b>	<b>26</b>	<b>5</b>	<b>130</b>	<b>162</b>	<b>416</b>	<b>88</b>	<b>4</b>	<b>670</b>	<b>392</b>	<b>77</b>	<b>340</b>	<b>4</b>	<b>813</b>	<b>34</b>	<b>306</b>	<b>125</b>	<b>1</b>	<b>466</b>	<b>2079</b>
<b>Grand Total</b>	<b>575</b>	<b>236</b>	<b>187</b>	<b>47</b>	<b>1045</b>	<b>1358</b>	<b>1706</b>	<b>680</b>	<b>25</b>	<b>3769</b>	<b>1361</b>	<b>349</b>	<b>1569</b>	<b>31</b>	<b>3310</b>	<b>253</b>	<b>1836</b>	<b>1190</b>	<b>27</b>	<b>3306</b>	<b>11430</b>
<b>Apprch %</b>	<b>55</b>	<b>22.6</b>	<b>17.9</b>	<b>4.5</b>		<b>36</b>	<b>45.3</b>	<b>18</b>	<b>0.7</b>		<b>41.1</b>	<b>10.5</b>	<b>47.4</b>	<b>0.9</b>		<b>7.7</b>	<b>55.5</b>	<b>36</b>	<b>0.8</b>		
<b>Total %</b>	<b>5</b>	<b>2.1</b>	<b>1.6</b>	<b>0.4</b>	<b>9.1</b>	<b>11.9</b>	<b>14.9</b>	<b>5.9</b>	<b>0.2</b>	<b>33</b>	<b>11.9</b>	<b>3.1</b>	<b>13.7</b>	<b>0.3</b>	<b>29</b>	<b>2.2</b>	<b>16.1</b>	<b>10.4</b>	<b>0.2</b>	<b>28.9</b>	



# MINNESOTA DEPT OF TRANSPORTATION

## TRAFFIC DATA COLLECTION - METRO

File Name : ELM CREEK PKWY AT JEFFERSON CT- JEFFERSON HWY 2006  
 Site Code : 00000000  
 Start Date : 6/14/2006  
 Page No : 2

Start Time	JEFFERSON CT/JEFFERSON HWY Southbound					ELM CREEK PKWY Westbound					JEFFERSON CT/JEFFERSON HWY Northbound					ELM CREEK PKWY Eastbound					Int. Total
	LEFT	THRU	RIGHT	Peds	App. Total	LEFT	THRU	RIGHT	Peds	App. Total	LEFT	THRU	RIGHT	Peds	App. Total	LEFT	THRU	RIGHT	Peds	App. Total	
Peak Hour Analysis From 06:00 to 09:45 - Peak 1 of 1																					
Peak Hour for Entire Intersection Begins at 07:00																					
07:00	20	7	4	0	31	47	23	14	0	84	6	6	12	0	24	10	55	70	0	135	274
07:15	17	<b>16</b>	<b>9</b>	<b>1</b>	43	60	<b>33</b>	<b>16</b>	<b>2</b>	111	11	2	16	0	29	<b>14</b>	67	66	<b>1</b>	148	331
07:30	14	15	4	1	34	72	20	<b>31</b>	0	123	9	4	20	0	33	7	80	<b>96</b>	0	<b>183</b>	373
07:45	<b>21</b>	15	9	0	<b>45</b>	<b>75</b>	31	26	0	<b>132</b>	<b>26</b>	<b>10</b>	<b>23</b>	0	<b>59</b>	7	<b>82</b>	89	0	178	<b>414</b>
Total Volume	72	53	26	2	153	254	107	87	2	450	52	22	71	0	145	38	284	321	1	644	1392
% App. Total	47.1	34.6	17	1.3		56.4	23.8	19.3	0.4		35.9	15.2	49	0		5.9	44.1	49.8	0.2		
PHF	.857	.828	.722	.500	.850	.847	.811	.702	.250	.852	.500	.550	.772	.000	.614	.679	.866	.836	.250	.880	.841

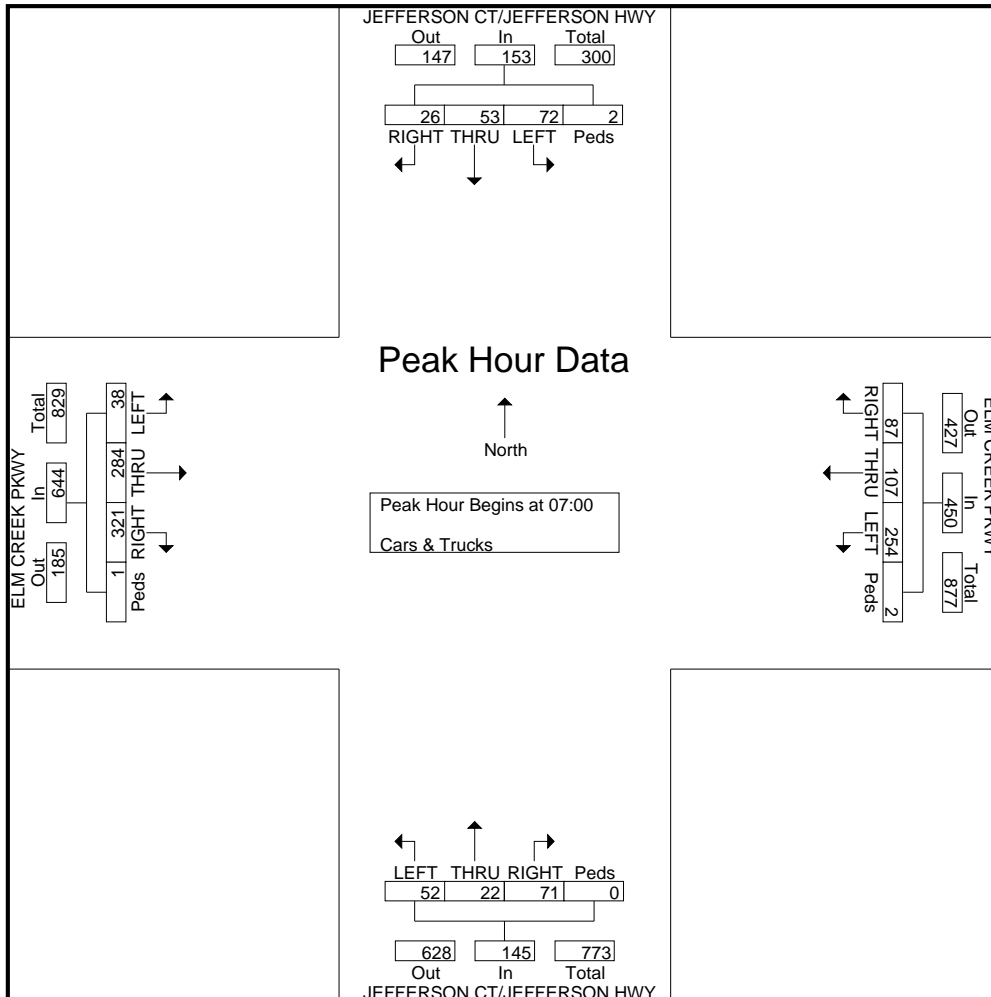



# MINNESOTA DEPT OF TRANSPORTATION

## TRAFFIC DATA COLLECTION - METRO

File Name : ELM CREEK PKWY AT JEFFERSON CT- JEFFERSON HWY 2006  
 Site Code : 00000000  
 Start Date : 6/14/2006  
 Page No : 3

Start Time	JEFFERSON CT/JEFFERSON HWY Southbound					ELM CREEK PKWY Westbound					JEFFERSON CT/JEFFERSON HWY Northbound					ELM CREEK PKWY Eastbound					Int. Total
	LEFT	THRU	RIGHT	Peds	App. Total	LEFT	THRU	RIGHT	Peds	App. Total	LEFT	THRU	RIGHT	Peds	App. Total	LEFT	THRU	RIGHT	Peds	App. Total	
Peak Hour Analysis From 10:00 to 13:45 - Peak 1 of 1																					
Peak Hour for Entire Intersection Begins at 12:00																					
12:00	32	12	2	0	46	47	48	33	0	128	41	17	71	2	131	10	64	27	0	101	406
12:15	23	6	5	1	35	43	46	33	1	123	32	11	53	0	96	9	42	26	3	80	334
12:30	20	4	9	1	34	49	58	30	4	141	23	10	58	1	92	8	39	23	2	72	339
12:45	22	3	6	0	31	45	54	20	0	119	27	7	47	0	81	10	58	38	4	110	341
Total Volume	97	25	22	2	146	184	206	116	5	511	123	45	229	3	400	37	203	114	9	363	1420
% App. Total	66.4	17.1	15.1	1.4		36	40.3	22.7	1		30.8	11.2	57.2	0.8		10.2	55.9	31.4	2.5		
PHF	.758	.521	.611	.500	.793	.939	.888	.879	.313	.906	.750	.662	.806	.375	.763	.925	.793	.750	.563	.825	.874

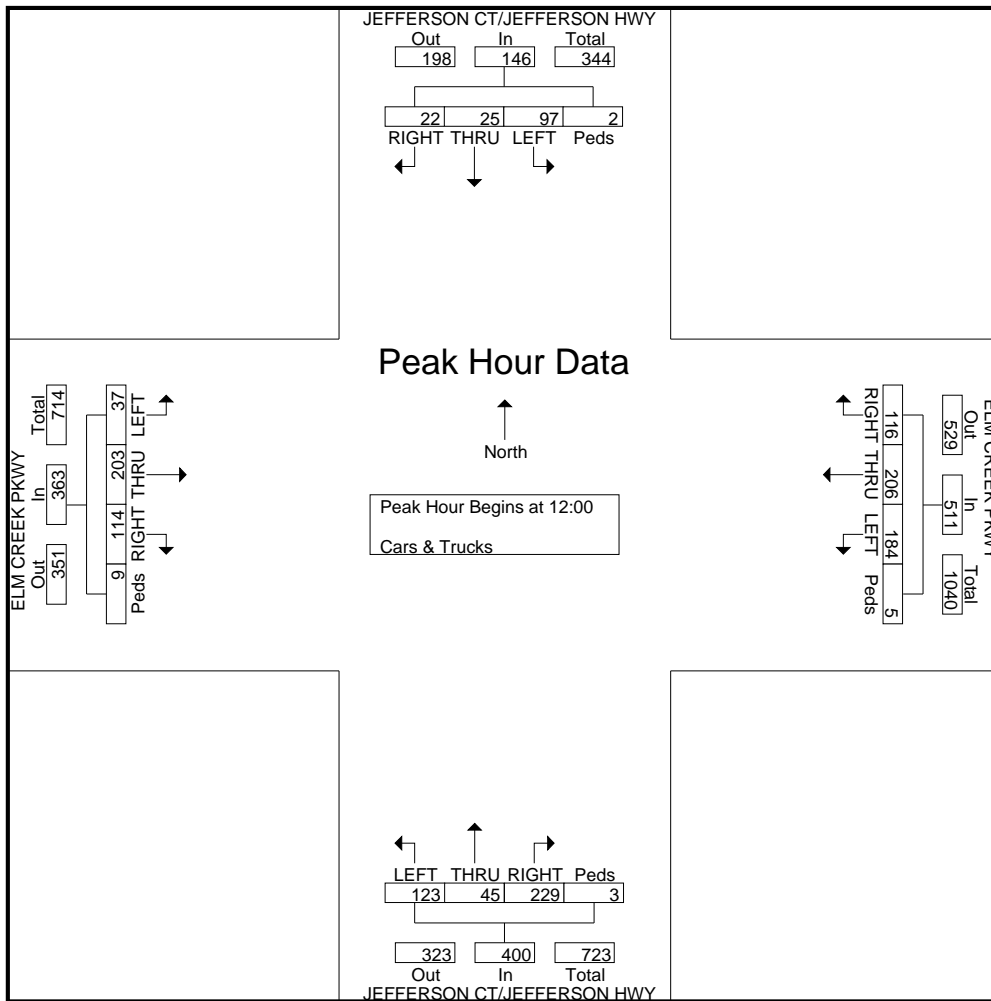



# MINNESOTA DEPT OF TRANSPORTATION

## TRAFFIC DATA COLLECTION - METRO

File Name : ELM CREEK PKWY AT JEFFERSON CT- JEFFERSON HWY 2006  
 Site Code : 00000000  
 Start Date : 6/14/2006  
 Page No : 4

Start Time	JEFFERSON CT/JEFFERSON HWY Southbound					ELM CREEK PKWY Westbound					JEFFERSON CT/JEFFERSON HWY Northbound					ELM CREEK PKWY Eastbound					Int. Total
	LEFT	THRU	RIGHT	Peds	App. Total	LEFT	THRU	RIGHT	Peds	App. Total	LEFT	THRU	RIGHT	Peds	App. Total	LEFT	THRU	RIGHT	Peds	App. Total	
Peak Hour Analysis From 14:00 to 17:45 - Peak 1 of 1																					
Peak Hour for Entire Intersection Begins at 17:00																					
17:00	20	3	7	0	30	46	103	16	1	166	99	20	109	1	229	9	63	26	0	98	523
17:15	27	8	6	1	42	47	96	35	0	178	114	16	81	1	212	3	57	39	1	100	532
17:30	14	5	8	2	29	34	121	11	3	169	85	12	84	2	183	15	84	25	0	124	505
17:45	22	0	5	2	29	35	96	26	0	157	94	29	66	0	189	7	102	35	0	144	519
Total Volume	83	16	26	5	130	162	416	88	4	670	392	77	340	4	813	34	306	125	1	466	2079
% App. Total	63.8	12.3	20	3.8		24.2	62.1	13.1	0.6		48.2	9.5	41.8	0.5		7.3	65.7	26.8	0.2		
PHF	.769	.500	.813	.625	.774	.862	.860	.629	.333	.941	.860	.664	.780	.500	.888	.567	.750	.801	.250	.809	.977

