

Alliant Engineering Inc Minneapolis, MN 55415

Flying Cloud Drive at Fountain Place
Eden Prairie
data by: Alliant Engineering
TURN MOVEMENT COUNT

File Name : 05_Flying Cloud Drive at Fountain Place
Site Code : 00000005
Start Date : 10/13/2009
Page No : 1

Groups Printed- Unshifted - Bank 1

Start Time	Flying Cloud Drive (TH 212) Southbound				Entrance Westbound				Flying Cloud Drive (TH 212) Northbound				Fountain Place Eastbound				Int. Total
	Left	Thru	Right	Peds	Left	Thru	Right	Peds	Left	Thru	Right	Peds	Left	Thru	Right	Peds	
06:30	5	73	6	0	0	0	3	0	0	187	1	0	14	0	0	0	289
06:45	2	106	5	0	0	0	1	0	3	269	3	0	17	0	2	0	408
Total	7	179	11	0	0	0	4	0	3	456	4	0	31	0	2	0	697
07:00	1	125	8	0	0	0	0	0	1	347	2	0	28	0	0	0	512
07:15	3	134	11	0	0	0	1	0	0	392	0	0	34	0	2	0	577
07:30	2	169	3	0	0	0	2	0	0	471	0	0	48	0	0	0	695
07:45	4	197	7	0	0	0	4	0	2	489	0	0	45	0	2	0	750
Total	10	625	29	0	0	0	7	0	3	1699	2	0	155	0	4	0	2534
08:00	3	130	4	0	1	0	0	0	1	346	0	0	43	1	4	0	533
08:15	6	123	16	0	0	0	3	0	3	325	4	0	52	0	1	0	533
08:30	4	128	19	0	1	0	2	0	4	269	6	0	45	1	1	2	482
08:45	15	119	18	0	0	0	7	0	2	259	3	0	43	2	1	0	469
Total	28	500	57	0	2	0	12	0	10	1199	13	0	183	4	7	2	2017
09:00	6	91	20	0	0	0	4	0	6	205	2	0	39	1	0	0	374
09:15	9	88	23	0	2	1	3	0	3	182	4	0	40	3	2	0	360
*** BREAK ***																	
Total	15	179	43	0	2	1	7	0	9	387	6	0	79	4	2	0	734
*** BREAK ***																	
10:30	7	101	32	0	1	1	11	0	5	123	2	0	30	2	2	0	317
10:45	5	118	31	0	1	1	12	0	10	164	6	0	39	1	7	0	395
Total	12	219	63	0	2	2	23	0	15	287	8	0	69	3	9	0	712
11:00	6	103	42	0	4	2	17	0	8	169	2	0	35	0	5	0	393
11:15	10	130	36	0	1	2	9	0	11	190	2	0	32	2	6	0	431
11:30	4	165	47	0	2	3	8	0	5	216	1	0	47	0	2	0	500
11:45	9	190	70	0	2	0	5	0	8	251	3	0	44	1	8	0	591
Total	29	588	195	0	9	7	39	0	32	826	8	0	158	3	21	0	1915
12:00	2	170	69	0	0	0	11	0	12	212	2	0	47	0	7	0	532
12:15	5	220	67	0	1	0	6	0	10	206	0	0	49	1	9	0	574
12:30	1	197	55	1	1	2	13	1	6	194	2	1	38	0	16	0	528
12:45	9	182	52	0	1	2	8	0	11	186	1	0	51	1	12	0	516
Total	17	769	243	1	3	4	38	1	39	798	5	1	185	2	44	0	2150
13:00	11	183	68	0	2	1	7	0	8	216	3	0	47	0	5	0	551
13:15	11	177	71	1	0	0	5	2	6	155	4	0	43	3	6	0	484
*** BREAK ***																	
Total	22	360	139	1	2	1	12	2	14	371	7	0	90	3	11	0	1035
*** BREAK ***																	
14:30	4	172	47	0	1	0	5	0	4	179	2	0	22	2	3	0	441
14:45	10	177	32	0	1	2	6	0	6	130	0	0	27	2	9	0	402
Total	14	349	79	0	2	2	11	0	10	309	2	0	49	4	12	0	843
15:00	10	183	56	0	0	2	11	0	7	165	2	0	22	1	11	0	470
15:15	11	213	56	0	4	1	10	0	4	159	1	1	21	0	11	0	492
15:30	6	217	55	0	3	1	10	1	7	189	3	2	36	1	9	2	542
15:45	7	229	42	1	1	0	5	1	6	151	2	1	39	0	3	0	488
Total	34	842	209	1	8	4	36	2	24	664	8	4	118	2	34	2	1992
16:00	3	317	50	1	2	1	3	1	6	187	3	0	20	0	9	0	603
16:15	6	318	49	1	1	0	4	1	8	181	2	0	26	0	5	0	602
16:30	7	391	65	0	1	1	11	0	8	185	3	0	30	0	4	0	706
16:45	6	380	82	0	2	0	6	1	7	195	1	0	39	1	7	0	727
Total	22	1406	246	2	6	2	24	3	29	748	9	0	115	1	25	0	2638

Alliant Engineering Inc Minneapolis, MN 55415

Flying Cloud Drive at Fountain Place
Eden Prairie
data by: Alliant Engineering
TURN MOVEMENT COUNT

File Name : 05_Flying Cloud Drive at Fountain Place
Site Code : 00000005
Start Date : 10/13/2009
Page No : 2

Groups Printed- Unshifted - Bank 1

Start Time	Flying Cloud Drive (TH 212) Southbound				Entrance Westbound				Flying Cloud Drive (TH 212) Northbound				Fountain Place Eastbound				Int. Total
	Left	Thru	Right	Peds	Left	Thru	Right	Peds	Left	Thru	Right	Peds	Left	Thru	Right	Peds	
17:00	1	402	66	0	2	1	10	0	3	205	3	1	29	0	16	1	740
17:15	3	416	71	0	1	0	4	0	15	232	1	0	34	0	13	0	790
17:30	3	392	72	0	1	0	7	0	13	198	2	0	29	0	9	0	726
17:45	1	408	59	0	2	0	4	0	4	164	1	0	26	1	17	0	687
Total	8	1618	268	0	6	1	25	0	35	799	7	1	118	1	55	1	2943
18:00	6	213	57	0	1	0	6	0	9	193	2	0	34	1	8	0	530
18:15	5	227	66	0	3	1	7	0	12	148	1	0	31	0	10	0	511
18:30	6	204	47	0	1	0	6	0	6	159	5	0	35	2	7	0	478
18:45	9	180	56	0	2	0	3	0	1	125	1	0	19	2	9	0	407
Total	26	824	226	0	7	1	22	0	28	625	9	0	119	5	34	0	1926
Grand Total	244	8458	1808	5	49	25	260	8	251	9168	88	6	1469	32	260	5	22136
Apprch %	2.3	80.4	17.2	0	14.3	7.3	76	2.3	2.6	96.4	0.9	0.1	83.2	1.8	14.7	0.3	
Total %	1.1	38.2	8.2	0	0.2	0.1	1.2	0	1.1	41.4	0.4	0	6.6	0.1	1.2	0	
Unshifted	240	8377	1801	5	49	25	255	8	249	9013	84	6	1467	32	260	5	21876
% Unshifted	98.4	99	99.6	100	100	100	98.1	100	99.2	98.3	95.5	100	99.9	100	100	100	98.8
Bank 1	4	81	7	0	0	0	5	0	2	155	4	0	2	0	0	0	260
% Bank 1	1.6	1	0.4	0	0	0	1.9	0	0.8	1.7	4.5	0	0.1	0	0	0	1.2

Alliant Engineering Inc Minneapolis, MN 55415

Flying Cloud Drive at Fountain Place
Eden Prairie
data by: Alliant Engineering
TURN MOVEMENT COUNT

File Name : 05_Flying Cloud Drive at Fountain Place
Site Code : 00000005
Start Date : 10/13/2009
Page No : 3

Start Time	Flying Cloud Drive (TH 212) Southbound					Entrance Westbound					Flying Cloud Drive (TH 212) Northbound					Fountain Place Eastbound					Int. Total
	Left	Thru	Right	Peds	App. Total	Left	Thru	Right	Peds	App. Total	Left	Thru	Right	Peds	App. Total	Left	Thru	Right	Peds	App. Total	
Peak Hour Analysis From 06:30 to 09:15 - Peak 1 of 1																					
Peak Hour for Entire Intersection Begins at 07:15																					
07:15	3	134	11	0	148	0	0	1	0	1	0	392	0	0	392	34	0	2	0	36	577
07:30	2	169	3	0	174	0	0	2	0	2	0	471	0	0	471	48	0	0	0	48	695
07:45	4	197	7	0	208	0	0	4	0	4	2	489	0	0	491	45	0	2	0	47	750
08:00	3	130	4	0	137	1	0	0	0	1	1	346	0	0	347	43	1	4	0	48	533
Total Volume	12	630	25	0	667	1	0	7	0	8	3	1698	0	0	1701	170	1	8	0	179	2555
% App. Total	1.8	94.5	3.7	0		12.5	0	87.5	0		0.2	99.8	0	0		95	0.6	4.5	0		
PHF	.750	.799	.568	.000	.802	.250	.000	.438	.000	.500	.375	.868	.000	.000	.866	.885	.250	.500	.000	.932	.852

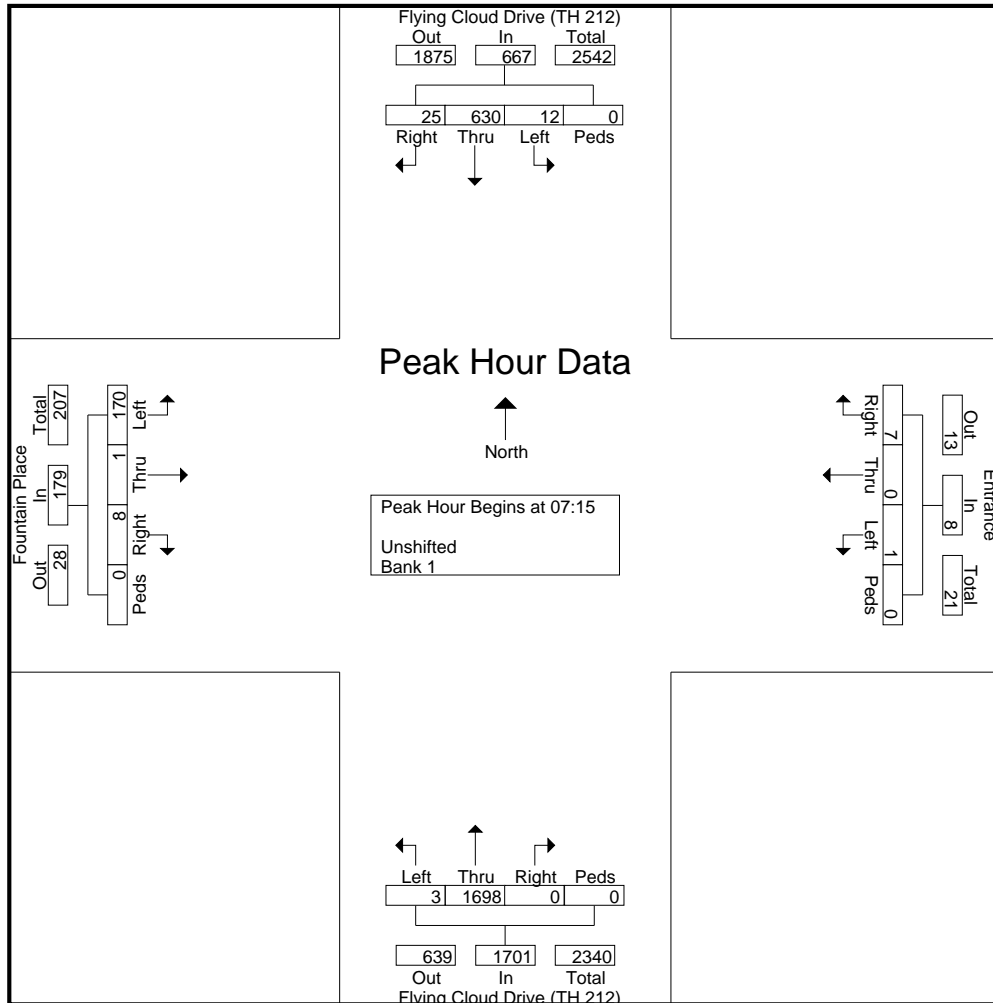

Alliant Engineering Inc Minneapolis, MN 55415

Flying Cloud Drive at Fountain Place
Eden Prairie
data by: Alliant Engineering
TURN MOVEMENT COUNT

File Name : 05_Flying Cloud Drive at Fountain Place
Site Code : 00000005
Start Date : 10/13/2009
Page No : 4

Start Time	Flying Cloud Drive (TH 212) Southbound					Entrance Westbound					Flying Cloud Drive (TH 212) Northbound					Fountain Place Eastbound					Int. Total
	Left	Thru	Right	Peds	App. Total	Left	Thru	Right	Peds	App. Total	Left	Thru	Right	Peds	App. Total	Left	Thru	Right	Peds	App. Total	
Peak Hour Analysis From 15:00 to 18:45 - Peak 1 of 1																					
Peak Hour for Entire Intersection Begins at 16:45																					
16:45	6	380	82	0	468	2	0	6	1	9	7	195	1	0	203	39	1	7	0	47	727
17:00	1	402	66	0	469	2	1	10	0	13	3	205	3	1	212	29	0	16	1	46	740
17:15	3	416	71	0	490	1	0	4	0	5	15	232	1	0	248	34	0	13	0	47	790
17:30	3	392	72	0	467	1	0	7	0	8	13	198	2	0	213	29	0	9	0	38	726
Total Volume	13	1590	291	0	1894	6	1	27	1	35	38	830	7	1	876	131	1	45	1	178	2983
% App. Total	0.7	83.9	15.4	0		17.1	2.9	77.1	2.9		4.3	94.7	0.8	0.1		73.6	0.6	25.3	0.6		
PHF	.542	.956	.887	.000	.966	.750	.250	.675	.250	.673	.633	.894	.583	.250	.883	.840	.250	.703	.250	.947	.944

