

# MN Dept of Transportation

TRAFFIC DATA COLLECTION - Metro

TH-95 at TH-243 / 260th St.  
 Ref.Pt.: 082.920  
 video  
 TURN MOVEMENT COUNT

File Name : th-95 at th-243 2015  
 Site Code :  
 Start Date : 6/18/2015  
 Page No : 1

Groups Printed- Cars + - Trucks

Start Time	TH-95 Southbound				TH-243 / Osceola Rd Westbound				TH-95 Northbound				260th St Eastbound				Int. Total
	Left	Thru	Right	Peds	Left	Thru	Right	Peds	Left	Thru	Right	Peds	Left	Thru	Right	Peds	
06:00	3	34	0	0	55	2	4	0	0	2	10	0	0	1	1	0	112
06:15	14	33	1	0	62	5	7	0	2	7	10	0	0	2	0	0	143
06:30	18	25	1	0	43	4	10	0	2	9	19	0	1	7	0	0	139
06:45	25	24	2	0	47	7	10	0	1	9	26	0	2	11	0	0	164
Total	60	116	4	0	207	18	31	0	5	27	65	0	3	21	1	0	558
07:00	12	35	2	0	43	10	9	0	0	11	21	0	2	5	7	0	157
07:15	10	29	1	0	62	6	16	0	0	14	29	0	1	7	2	0	177
07:30	11	24	0	0	44	15	8	0	1	16	25	0	0	12	0	0	156
07:45	15	23	2	0	37	4	15	0	0	19	32	0	1	8	1	0	157
Total	48	111	5	0	186	35	48	0	1	60	107	0	4	32	10	0	647
08:00	14	26	4	0	52	6	5	0	5	11	26	0	2	8	0	0	159
08:15	11	28	2	0	28	7	14	0	4	10	29	0	3	6	2	0	144
08:30	7	16	0	0	37	6	7	0	0	13	25	0	1	6	7	0	125
08:45	5	25	0	0	26	5	7	0	2	12	23	0	0	8	0	0	113
Total	37	95	6	0	143	24	33	0	11	46	103	0	6	28	9	0	541
*****BREAK*****																	
15:00	15	19	1	0	27	7	10	0	0	32	43	0	1	5	0	0	160
15:15	13	15	2	0	35	7	10	0	4	50	54	0	2	3	0	0	195
15:30	9	18	0	0	43	9	20	0	1	35	54	0	0	7	4	0	200
15:45	11	30	0	0	33	11	18	0	2	52	62	0	0	9	1	0	229
Total	48	82	3	0	138	34	58	0	7	169	213	0	3	24	5	0	784
16:00	20	23	2	0	44	7	19	0	0	53	68	0	0	13	2	0	251
16:15	12	28	0	0	43	8	16	0	0	60	79	0	0	14	0	0	260
16:30	22	30	1	0	38	12	13	0	0	44	69	0	1	10	0	0	240
16:45	30	25	2	0	42	5	14	0	0	48	69	0	1	10	1	0	247
Total	84	106	5	0	167	32	62	0	0	205	285	0	2	47	3	0	998
17:00	16	27	1	0	36	7	20	0	1	59	75	0	0	10	0	0	252
17:15	19	21	0	0	26	3	14	0	1	45	74	0	1	12	0	0	216
17:30	14	32	1	0	45	4	13	0	0	64	57	0	0	9	0	0	239
17:45	11	20	0	0	31	8	9	0	1	47	59	0	0	10	1	0	197
Total	60	100	2	0	138	22	56	0	3	215	265	0	1	41	1	0	904
Grand Total	337	610	25	0	979	165	288	0	27	722	1038	0	19	193	29	0	4432
Apprch %	34.7	62.8	2.6	0	68.4	11.5	20.1	0	1.5	40.4	58.1	0	7.9	80.1	12	0	
Total %	7.6	13.8	0.6	0	22.1	3.7	6.5	0	0.6	16.3	23.4	0	0.4	4.4	0.7	0	
Cars +	331	597	14	0	925	161	281	0	6	713	986	0	9	191	5	0	4219
% Cars +	98.2	97.9	56	0	94.5	97.6	97.6	0	22.2	98.8	95	0	47.4	99	17.2	0	95.2
Trucks	6	13	11	0	54	4	7	0	21	9	52	0	10	2	24	0	213
% Trucks	1.8	2.1	44	0	5.5	2.4	2.4	0	77.8	1.2	5	0	52.6	1	82.8	0	4.8

# MN Dept of Transportation

TRAFFIC DATA COLLECTION - Metro

TH-95 at TH-243 / 260th St.  
 Ref.Pt.: 082.920  
 video  
 TURN MOVEMENT COUNT

File Name : th-95 at th-243 2015  
 Site Code :  
 Start Date : 6/18/2015  
 Page No : 2

Start Time	TH-95 Southbound					TH-243 / Osceola Rd Westbound					TH-95 Northbound					260th St Eastbound					Int. Total
	Left	Thru	Right	Peds	App. Total	Left	Thru	Right	Peds	App. Total	Left	Thru	Right	Peds	App. Total	Left	Thru	Right	Peds	App. Total	
Peak Hour Analysis From 06:00 to 08:45 - Peak 1 of 1																					
Peak Hour for Entire Intersection Begins at 06:45																					
06:45	25	24	2	0	51	47	7	10	0	64	1	9	26	0	36	2	11	0	0	13	164
07:00	12	35	2	0	49	43	10	9	0	62	0	11	21	0	32	2	5	7	0	14	157
07:15	10	29	1	0	40	62	6	16	0	84	0	14	29	0	43	1	7	2	0	10	177
07:30	11	24	0	0	35	44	15	8	0	67	1	16	25	0	42	0	12	0	0	12	156
Total Volume	58	112	5	0	175	196	38	43	0	277	2	50	101	0	153	5	35	9	0	49	654
% App. Total	33.1	64	2.9	0		70.8	13.7	15.5	0		1.3	32.7	66	0		10.2	71.4	18.4	0		
PHF	.580	.800	.625	.000	.858	.790	.633	.672	.000	.824	.500	.781	.871	.000	.890	.625	.729	.321	.000	.875	.924

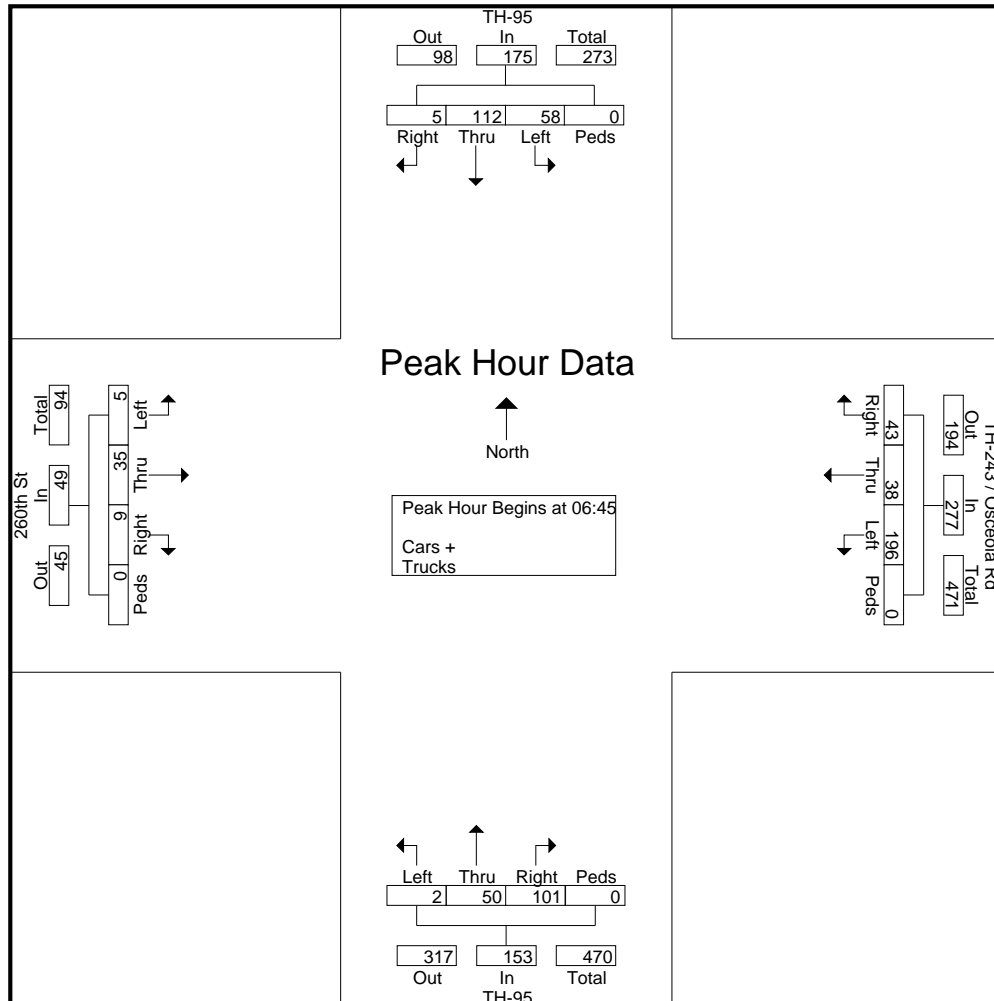

# MN Dept of Transportation

TRAFFIC DATA COLLECTION - Metro

TH-95 at TH-243 / 260th St.  
 Ref.Pt.: 082.920  
 video  
 TURN MOVEMENT COUNT

File Name : th-95 at th-243 2015  
 Site Code :  
 Start Date : 6/18/2015  
 Page No : 3

Start Time	TH-95 Southbound					TH-243 / Osceola Rd Westbound					TH-95 Northbound					260th St Eastbound					Int. Total
	Left	Thru	Right	Peds	App. Total	Left	Thru	Right	Peds	App. Total	Left	Thru	Right	Peds	App. Total	Left	Thru	Right	Peds	App. Total	
Peak Hour Analysis From 15:00 to 17:45 - Peak 1 of 1																					
Peak Hour for Entire Intersection Begins at 16:15																					
16:15	12	28	0	0	40	43	8	16	0	67	0	60	79	0	139	0	14	0	0	14	260
16:30	22	30	1	0	53	38	12	13	0	63	0	44	69	0	113	1	10	0	0	11	240
16:45	30	25	2	0	57	42	5	14	0	61	0	48	69	0	117	1	10	1	0	12	247
17:00	16	27	1	0	44	36	7	20	0	63	1	59	75	0	135	0	10	0	0	10	252
Total Volume	80	110	4	0	194	159	32	63	0	254	1	211	292	0	504	2	44	1	0	47	999
% App. Total	41.2	56.7	2.1	0		62.6	12.6	24.8	0		0.2	41.9	57.9	0		4.3	93.6	2.1	0		
PHF	.667	.917	.500	.000	.851	.924	.667	.788	.000	.948	.250	.879	.924	.000	.906	.500	.786	.250	.000	.839	.961

